



WORM GEAR DRIVES

B

Worm Gear Features.....	B-2 to B-6
Recess Action Worm Gearing.....	B-7
Rating Parameters.....	B-8
Pre-Selection Information.....	B-9
How To Select and Order Standard Models.....	B-10
Single Reduction Worm Gear Drives.....	B-11 to B-50
Model Index.....	B-12
Helical-Worm Units with Ratio Multipliers.....	B-51
Double Reduction Worm Gear Drives.....	B-55 to B-86
Model Index.....	B-56
Triple Reduction Worm Gear Drives.....	See Pg B-86
Accessories and Factory Options.....	B-87 to B-97
GW Series Dimensional Comparison.....	B-98



WORM GEAR DRIVES

Single, Double and Triple Reduction

BASIC SPECIFICATIONS

- Power Ratings from 1/4 to 104 hp
- Output Torque to 80,000 inch/lbs
- Ratios from 5:1 through 216,000:1
- Output Speeds .0081 rpm to 350 rpm

STANDARD FEATURES

- Over 30 series and 250 standard models available.
- Recess action gear design provides for more efficient operation and greater durability.
- Cast iron housing designed for superior thermal conductivity provides rigid gear and bearing support.
- Alloy shafting for greater strength.
- Hardened and ground worm and alloy bronze gear for greater wear life.
- 20° - 25° - 30° pressure angle design provides for more efficient operation and greater durability.

OPTIONAL FEATURES

- Modified Standard and Custom Designs
- Metric, Servo or Hydraulic input flanges
- CleanLine Washdown and BISSC Configurations
- Unique or Harsh Environment Adaptations
- Three lube options: 600W, synthetic, polyglycol, (130-380 Series only)

MOTORIZED WORM GEAR DRIVES

- Motors produced by Marathon Electric for High Efficiency, Reliability and Durability
- General or Definite Purpose Motors
- Brake or Inverter Duty Motors, DC or Washdown Motors
- Motor/Gear Drive Package Incentives Available, Consult Factory

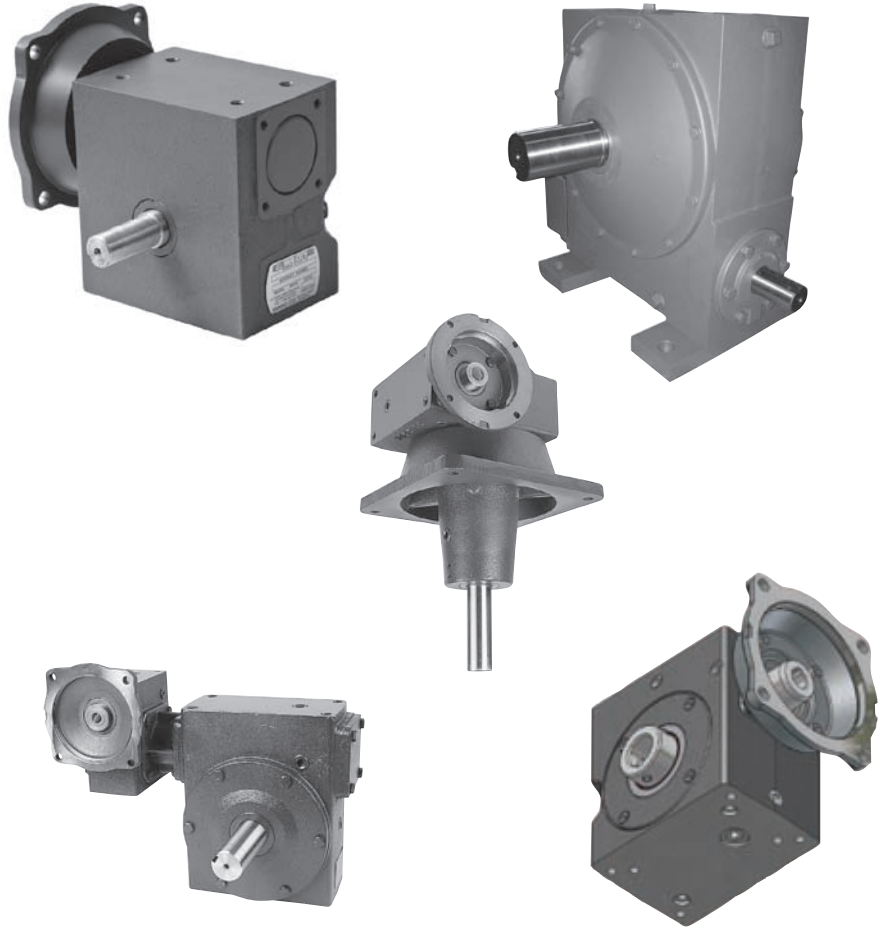

**For Available Electric Motors
Sections H**

**For Stainless Steel
Worm Gear Drives
See HUB®
Section O**

**For Compact Light Weight Aluminum
Worm Gear Drives
See Spartan Worm Gear Drives
Section C**

**For Sub-Fractional Worm Gearmotors See
Mina-Gear Gearmotors
Section P**

**For High Efficiency
Right Angle Gear Drives
See Poweratio® 2000
Helical Bevel and Helical Worm Units
Sections K & L**



DESIGN FEATURES

NEW UNIVERSAL POWER CUBE™ WORM GEAR REDUCERS

SERIES 130 TO 380 (1.33" TO 3.75" CENTER DISTANCE) MODELS

B

FEATURES

- Addition of 240 series (2-3/8" CD)
- Up to 30% increase in mechanical power ratings. Meets or exceeds new industry ratings
- Increased thermal capacity and Increased efficiency
- Offers Hub City and "generic" bolt mounting patterns on bottom surface, and Hub City mounting pattern on top mounting surface
- Eliminates need for generic base plates
- Smooth design for enhanced washdown characteristics
- Three lube options: 600W, synthetic, polyglycol, NO thermal limitations when specified with premium polyglycol lubricant
- Cast iron housing designed for superior thermal conductivity provides maximum surface area for increased heat dissipation and higher thermal ratings.
- Alloy shafting for greater strength.
- Worms have improved heat treat for higher capacity, and polished threads for increased efficiency and higher thermal ratings.
- Worm gears have been upgraded to nickel-tin bronze for increased mechanical and thermal capacity, and have optimized face widths for higher horsepower ratings.
- 20° - 25° - 30° pressure angle design provides for more efficient operation and greater durability.
- Ball bearings on all high speed shafts 130 thru 380.
- Tapered roller bearings on the low speed shaft (Except series 130 is ball bearings)
- Seals are Viton or HNBR to allow higher operating temperatures and provide longer life.
- Accessory kits such as Side Mount Flange Bracket Kit (shown), Vertical Mt Bracket & Shaft Kit (shown), Base Kits and and Torque Arm Kits are available for Universal Power Cube models (see pages B-87-97)

All the above features and upgrades are REAL improvements that justify the increased mechanical and thermal ratings of the new Power Cube gear drives. These increased ratings will allow downsizing for a lower cost unit in some applications, or increased performance and life in existing applications.

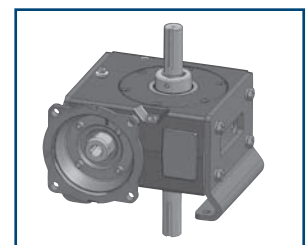
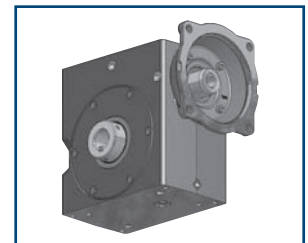
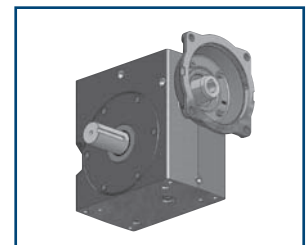
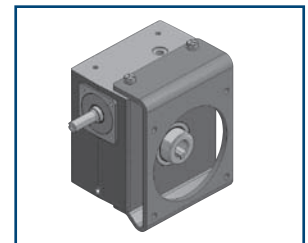
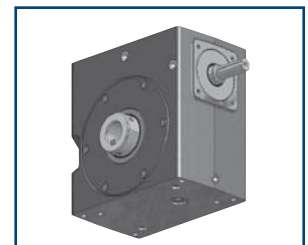
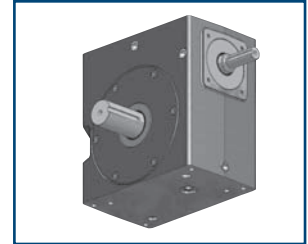



DESIGN FEATURES CENTURY SERIES WORM GEAR REDUCERS

SERIES 450 TO 520 (4.50" TO 5.16" CENTER DISTANCE) MODELS

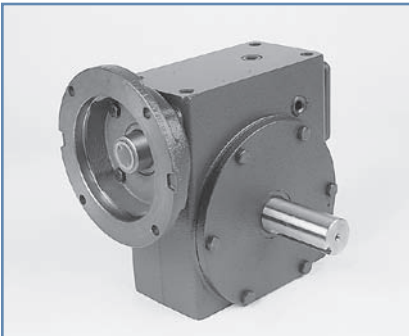
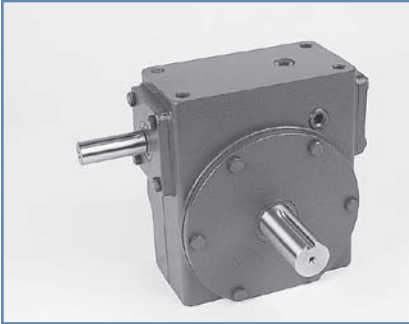

FEATURES

- Cast iron housing provides rigid gear and bearing support.
- Alloy shafting for greater strength.
- Hardened and ground worm and alloy bronze gear for greater wear life.
- 20° - 25° - 30° pressure angle design provides for more efficient operation and greater durability.
- High speed shaft bearings are double tapered roller bearings on C-face quill type models
- Tapered roller bearings on high speed shaft on shaft input models
- Tapered roller bearings on the low speed shaft
- The 450 and 520 series have no dimension changes in the housing or other components, but they benefit from gearing improvements and synthetic oils as described below.
- Worms have improved heat treat for higher capacity, and polished threads for increased efficiency and higher thermal ratings.
- Worm gears have been upgraded to nickel-tin-bronze for increased mechanical and thermal capacity, and have optimized face widths for higher horsepower ratings.
- Shaft mounted models designed for direct mounting on drive shaft of equipment to be driven. Provides a positive and permanent alignment of reducer to the driven machine.
- NEMA "C" Flange Adaptor kits available for direct mounting to electric motor. (page B-91)
- Torque arm kits available see page B-95.
- **"QD"® Bushings provide widest possible range of bore size, ease of installation and removal. Available in shaft mounted models in series 450 and 520.
- Thermal Block, Fan kits and Synthetic lubricants are available to increase thermal capacity
- Drop bearing design models provide overhung load support for trolleys, conveyors, agitators, mixers and other similar applications. Grease retainer at out board bearing for mounting output shaft vertically up. Large outboard bearing for long bearing life. Tandem Seals (Taconite) on output shaft with grease and purge holes provided.



DESIGN FEATURES GW SERIES WORM GEAR REDUCERS

SERIES GW60 TO GW100 (6" TO 10" CENTER DISTANCE) MODELS

B

FEATURES

- Rugged iron housings, covers, and flanges provide superior strength and rigidity.
- Two separate housings in the double reduction design insures long trouble free life of all components.
- The worm shaft is cut integral with the input shaft then hardened, ground, and polished to provide maximum efficiency with minimum gear noise.
- The bronze worm gear is chill cast from the highest quality bronze to provide superior wear and lubricity characteristics for longer life and higher efficiency.
- Premium tapered roller bearings on output shafts provide greater life, overhung load and thrust capacity.
- Oversized steel output shafts provide superior overhung load and torque characteristics.
- Large oil capacity provides positive splash lubrication and superior cooling capability.
- Metal nameplate drive screwed to housing insures easy field identification for repair parts and replacement.
- All units are 100% run and leak tested at the factory to insure that you receive the highest quality product.

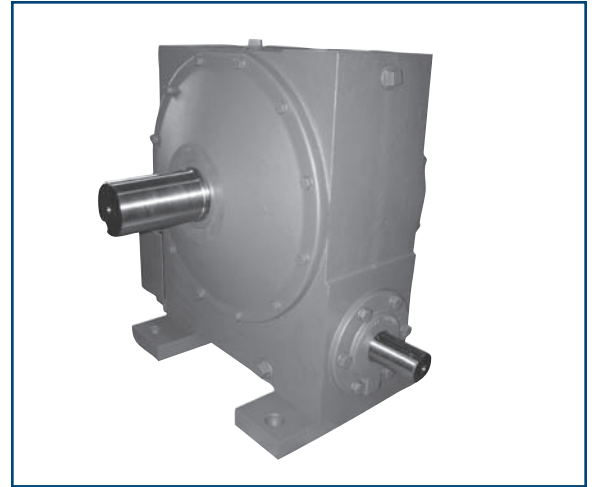

LUBRICANT OPTIONS FOR ALL HUB CITY WORM GEAR DRIVES

- Hub City has done extensive testing on different oil types, to compare wear resistance, efficiency, and thermal ratings. Hub City publishes three sets of catalog ratings, with different oil types, so the customer can choose the ideal oil for each application. Ratings are provided for conventional mineral oil, such as Mobil 600W Cylinder Oil, traditional "PAO" (polyalphaolephin) synthetic oil, such as Mobil SHC-634, and the newer "PAG" (polyalkaline glycol) synthetic oil, such as Klubersynth UH1 6-460 and Mobil Glygoyle 460.
- The traditional "PAO" synthetic oil has broader temperature range, both high and low, increased efficiency for higher thermal ratings, and longer life for fewer oil changes, and needs no replacement in many applications.
- The newer "PAG" synthetic oil also has broader high and low temperature range, and has the highest efficiency for the maximum thermal ratings. THE PAG SYNTHETIC OIL ALLOWS ALL POWER CUBE UNITS FROM 130 SERIES THROUGH 380 SERIES TO RUN CONTINUOUSLY AT CATALOG MECHANICAL RATINGS, WITH NO THERMAL DERATING. This oil meets the FDA H1 approval for use in food plants where there is the possibility of incidental contact with food. The PAG synthetic oils also provide longer life for fewer oil changes, and need no replacement in many applications.
- **NOTE:** The PAG synthetic oils are NOT COMPATIBLE with any other types of oil, and oils must not be mixed. If changing a unit to or from PAG oil, the unit must be thoroughly flushed out with the new oil. Water can mix with the PAG synthetic oil, and does not separate, so this must be taken into consideration by protecting units from moisture ingestion, and in severe applications, oil changes may be required.
- Because PAG synthetic oils are not readily available in many locations, Hub City can provide units that are filled at the factory with PAG oil. These units have unique part numbers for permanent identification. The model numbers use an "L" suffix, such as 214L. Mounting position must be specified and included in the reducer description so the correct amount of oil is installed. (See pages B-10 and B-13)



DESIGN FEATURES (cont'd)

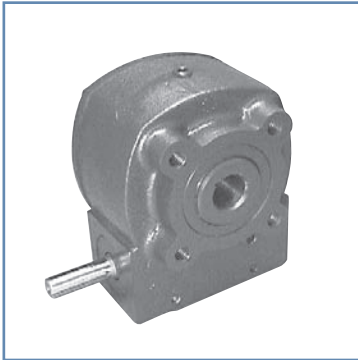

W-SERIES STANDARD FEATURES

- Constructed with all cast iron alloy housings.
- Tapered roller bearings
- Heavy-duty industrial seals
- Shaft mounted for direct mounting on drive shafts.
- W300 also available with light weight aluminum housing.



TORQUE PLUS HELICAL RATIO MULTIPLIER STANDARD FEATURES

- Three Cast Iron Models, Two Aluminum Models, One Stainless Steel Model (See Section O)
- Ratios available from 2:1 to 7.5:1
- Can be used as reducer or increaser.
- Provides additional reduction capability when mounted onto Helical Gear Reducer or Worm Gear Reducer
- C-flange or solid input shaft.
- Helical gearing.
- Double lip seals.
- Base mounting available.
- Permanently lubricated at factory.



DOUBLE REDUCTION FEATURES

- Provides all the same basic features as the single reduction unit with two Hub City gearboxes connected.
- Available in ratios from 50:1 to 3600:1
- 90 different models to choose from.
- See Model Index page B-56 for series and model page number.

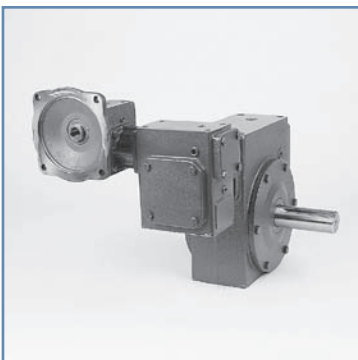

TRIPLE REDUCTION FEATURES

- Provides all the same basic features as the single and double reduction units with three Hub City gearboxes connected.
- Available in ratios from 1000:1 to 216,000:1
- Different models to choose from. Not shown in this catalog. See www.hubcityinc.com



RECESS ACTION WORM GEARING

With the introduction of High Efficiency motors and the rising cost of energy machine designers and equipment builders are demanding equipment and components that operate at higher efficiency levels. HUB CITY has designed their own worm gear speed reducers around a system of gearing that substantially increases the efficiency. This system is called "RECESS ACTION WORM GEARING". Recess action worm gearing is a venerable and well proven gear system. The greatest enemy of worm gearing is heat, heat generated by friction resulting from the rubbing action between the worm and worm gear. By reducing friction an entire series of benefits are gained, such as a substantial increase in efficiency,

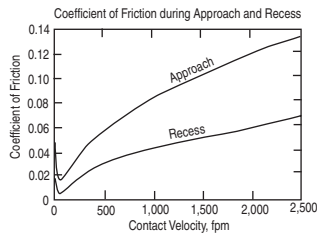
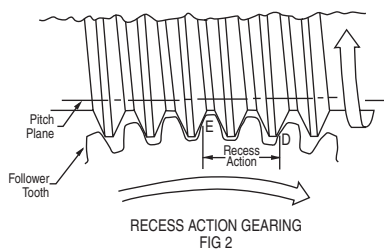
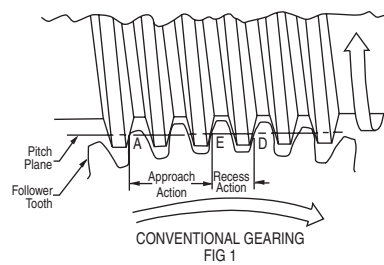

FIG 3

in approach action, and are in the direction that aids rotation. In addition recess action tends to cold work the gear surfaces improving the contact and load capacity.

Fig. 2 shows the same gear set in recess action. Slight modification of the tooth profile moves the pitch plane from its normal center location to the outside diameter of the follower member. The initial point of contact now occurs at point E which is on the line of centers of the gear system. This contact then progresses to point D which is completely recess action. The recess action gear system therefore offers all the advantages that occur in the recess action portion of a conventional gearing system and avoids the problem conditions that occur in the approach action.

A good example of recess action can be illustrated by a water wheel. If the water spout is behind the vertical center line of the water wheel, the buckets will be filled before they reach the high point of the wheel. Some energy of the water will be expended in lifting the full buckets to the high point of the wheel and therefore there will be a power loss. This is the same as approach action. If, however, the

buckets are filled at the vertical center point of the wheel, then all of the energy of the water will be used in the rotation of the wheel and the amount of power delivered by the wheel will be much greater.

In addition to full recess action gearing, the Hub City gearing system also employs the use of larger pressure angles than are normally found in conventional worm gear sets. The pressure angles utilized in these gear sets are 20°, 25° and 30°. The use of larger pressure angles enables the gear sets to have a wider face width and still maintain conjugate action of the tooth forms. The combination of larger pressure angles, wider face widths, and the use of high alloy bronze materials, results in worm gear teeth that are capable of substantially higher bending loads and surface wear loads.

Fig. 1 shows a conventional gear system with the pitch plane at one-half the working depth. Initial contact takes place at point A (note the direction of rotation) where the follower tooth begins to dig into the tip of the driver tooth. As contact progresses from point A to point E there is approach action. Approach action is a sliding in. It has a detrimental scraping action which tends to wear away the surface of the gears. The friction is very high (note Fig. 3) causing scuffing and the direction of the friction vector in approach action opposes the direction of rotation. From point E to point D there is recess action. Recess action is a sliding out with the follower gear tooth moving away from the driver.

The friction forces in recess action are lower than those

in approach action, and are in the direction that aids rotation. In addition recess action tends to cold work the gear surfaces improving the contact and load capacity.

Fig. 4 shows the contact lines of a conventional worm gear set projected on the end view of the worm. The contact starts at the outside diameter of the worm gear and travels up to the outside diameter of the worm. Fig. 5 shows the contact lines of a recess action worm gear set projected on the end view of the worm. Here the contact lines progress across the face of the worm gear. The total length of the contact lines in Fig. 5 is less than that in Fig. 4, but the position of the contact lines are more favorable relative curvatural conditions so that the unit loading in regard to surface stresses can be nearly double those of the lines shown in Fig. 4. The actual wear load capacity in Fig. 5 is about 150% of that shown in Fig. 4. The loading of the worm thread as a cantilever beam is substantially that of concentrated loads in Fig. 4 while it approaches that of uniformly applied loads in Fig. 5.

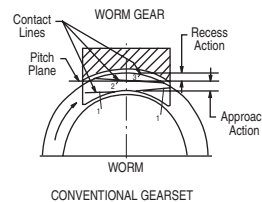

FIG 4

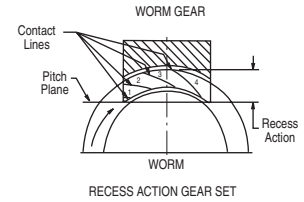

FIG 5

In a worm gear set the lubrication that does the most good is carried on the face of the worm gear teeth. The lubricant on the worm thread surface tends to be scraped off by the lines of contact. The lubricant on a worm gear tooth is pushed ahead of the contact lines. Through the period of engagement the same thread on the worm is in continuous contact with the same tooth on the gear.

In Fig. 4 the lubricant on the worm thread is practically exhausted by the left part of the contact lines so that the right part of the contact lines see virtually none of the lubricant. The lubricant on the worm gear tooth of the conventional worm gear set is pushed ahead of the contact lines toward the outside diameter of the worm. In Fig. 5 the lubricant on the gear tooth and worm thread is continually swept ahead of the contact, resulting in more adequate lubrication of both the worm thread and the worm gear tooth.

A continuing test program in the Hub City test facility has proven that recess action worm gears are capable of carrying higher gear loads with less gear wear. The increased efficiency of the gear sets results in less energy loss of the Hub City worm gear speed reducers.



RATING PARAMETERS

MECHANICAL RATINGS

The mechanical capacity of a worm gear reducer is generally based on the surface endurance limit of the bronze gear material, and the hardness and surface finish of the steel worm. In some low speed, high torque applications, the shear strength of the gear material may be the limiting factor.

Hub City mechanical catalog ratings are calculated to be used with a service factor of 1.0. This is for intermittent or continuous service free from shock loading, and a total duration of up to 10 hours per day. Applications outside these conditions require appropriate service factors to modify the allowable unit ratings. Table 1 defines the service factors for various operating conditions. Section A lists the AGMA service factors for various applications.

THERMAL RATINGS

The thermal capacity of a HUB CITY worm gear reducer is the actual horsepower (without service factor), which the reducer will transmit continuously for 2 hours or more without the oil temperature exceeding 200 deg F. The housing and gearing improvements in PowerCube allow continuous operation at higher horsepower. In addition, the standard high temperature seals and optional synthetic oils allow Hub City reducers to operate in excess of 225 deg F continuously, to maximize the thermal capacity.

Thermal ratings may be ignored when the continuous operating period does not exceed 2 hours and the shutdown period equals or exceeds the operating period. However, when the operating period exceeds 2 hours, or the operating period exceeds the shutdown period, thermal ratings must be considered.

A reducer should be selected with a thermal rating that meets or exceeds the ACTUAL horsepower to be transmitted. Synthetic oils increase the thermal rating, and may allow a smaller unit to be selected. The larger housings and improved gearing, with the appropriate synthetic oil, make cooling fans unnecessary on the 380 series and smaller. Cooling fans are still available on the 450 series and larger.

Note that thermal ratings assume an ambient temperature of approximately 75 deg F. With higher ambient temperatures, the thermal ratings will be approximately 1% less, per degree above 75 deg F.

Worm gear units have a run-in period of about 50 hours. The polished worms improve the initial efficiency, but the units may run hotter during the run-in period. Abnormal heating does not necessarily mean that the unit is beyond the thermal capacity, unless heating is excessive or continues beyond the run-in period.

THERMAL DESIGN OPTIONS

The improvements to the new HUB CITY worm gear reducers reduce the need for some of the thermal design options that were offered in the past. The customer can use the comparative ratings with the 3 oil types to choose the ideal reducer for his application. (Cooling fans are still available as an option on the 450 series and larger.)

HUB CITY SYNTHETIC OIL is the traditional PAO (polyalphaolephin) type. It is available in quart containers and is normally stocked by our authorized distributors. The HUB CITY synthetic oil is recommended for all reducers to increase efficiency, reduce power consumption, extend or completely eliminate the need for periodic oil changes, and to increase the thermal capacity, potentially allowing the use of a smaller reducer for a given application.

The newer PAG (polyalkaline glycol) SYNTHETIC OIL provides the highest efficiency and thermal capacity, which exceed those obtained with the PAO Synthetic Oils. Since these oils are not readily available, HUB CITY offers a standard option of reducers filled at the factory with the PAG Synthetic Oil. This oil is not compatible with any other type of oil, and does not separate from water, so these factors must be taken into consideration in the unit selection, which may be affected by the environment the reducer is exposed to. It is available in quart bottles.

COOLING FANS are available as a factory installed option for all units from 450 through 60 series. Cooling fans are standard on GW70 through GW100 series reducers.

Cooling fans and synthetic oils may be used in combination and will provide compound effects to obtain the maximum thermal capacity for a reducer. The rating tables illustrate this.

Any continuous air circulation provided by the customer will increase the thermal capacity of all non-fan reducers, and potentially eliminate the need for thermal upgrades.

PRE-SELECTION INFORMATION

HUB CITY worm gear speed reducers are designed to permit many assembly variations.

Worm gear speed reducers are selected on the basis of gear ratio, speed, torque (or horsepower) and mounting required. Factory engineers and customer service personnel are always willing to assist with unit selection, in order to provide the most economical drive component.

The drive selection tables have been arranged so that once the gear ratio, speed, torque (or horsepower) and mounting are known, the HUB CITY model number can be easily obtained or determined. Service factors for various loads and power sources are also provided to effectively accommodate loading and power source fluctuations. The use of the tables require only a minimum effort to select the service factors.



PRE-SELECTION INFORMATION

SERVICE FACTORS

The ratings for gear drives in this manual are based on a service factor of 1.00, for uniform load and uniform power source, up to 10 hours of operation per day. For other operating conditions, the application horsepower or torque must be multiplied by the appropriate service factor, to determine the equivalent gear drive power rating. A gear drive should be selected with a rated capacity equal to or greater than the equivalent rating.

Table 1 designates recommended service factors for various conditions of load, power source, and duration of service.

AGMA Service Factors for Worm and Helical Worm Gearmotors and Reducers are listed in Section A.

Refer to page A-2 for further information and cautions on the selection of proper service factors.

ROTATION – Input (High Speed Shaft) to the Hub City “Worm Gear Reducer” can be either clockwise or counter-clockwise.

OPERATING CHARACTERISTICS

VELOCITY LIMITS – Worm gear speed reducers are limited in speed by the rubbing velocity of the gear set. Gear sets using a steel worm with a cast iron gear are limited to a rubbing velocity 500 feet per minute. Gear sets with a steel, heat treated ground worm and bronze gear are limited to a maximum rubbing velocity of 1,500 feet per minute.

Consult factory for ratings at speeds higher than shown in the standard rating tables.

MAXIMUM TORQUE – The minimum speed of 100 RPM DOES NOT illustrate the lowest recommended speed of the worm gear speed reducers. This minimum speed illustrates the maximum running torque of the gear box. The unit will efficiently run at speeds below 100 RPM. When it is necessary to know horsepower values at these lower speeds simply convert the torque shown at 100 RPM to horsepower using the actual operating speed. Maximum momentary or starting torque is limited to 300% of rated capacity for worm gear speed reducers

TABLE 1 – SERVICE FACTORS

PRIME MOVER	DURATION OF SERVICE PER DAY (1)	DRIVEN MACHINE LOAD CLASSIFICATION		
		UNIFORM	MEDIUM SHOCK	HEAVY SHOCK
Electric Motor	Occasional 1/2 hr.	*	*	1.00
	Intermittent 3 hrs.	*	1.00	1.25
	3 - 10 hours	1.00	1.25	1.50
	Over 10 hours	1.25	1.50	1.75
Electric Motor With Frequent Starts and Stops (2)	Occasional 1/2 hr.	*	1.00	1.25
	Intermittent 3 hrs.	1.00	1.25	1.50
	3 - 10 hours	1.25	1.50	1.75
	Over 10 hours	1.50	1.75	2.00
Multi-Cylinder Internal Combustion Engine	Occasional 1/2 hr.	*	1.00	1.25
	Intermittent 3 hrs.	1.00	1.25	1.50
	3 - 10 hours	1.25	1.50	1.75
	Over 10 hours	1.50	1.75	2.00
Single Cylinder Internal Combustion Engine	Occasional 1/2 hr.	1.00	1.25	1.50
	Intermittent 3 hrs.	1.25	1.50	1.75
	3 - 10 hours	1.50	1.75	2.00
	Over 10 hours	1.75	2.00	2.25
Reversing Service Application		Consult Factory		

* UNSPECIFIED SERVICE FACTORS SHOULD BE 1.0 OR AS AGREED UPON BY USER AND MANUFACTURER.

EXPLANATORY NOTES

1. Time specified for intermittent and occasional service refers to total operating time per day.
2. Term “frequent starts and stops” refers to more than 10 starts per hour.



HOW TO SELECT AND ORDER STANDARD MODELS

When ordering a worm gear reducer, it is necessary to select reducer size (series), gear ratio, model, and assembly style. If accessories are required, they must be ordered separately and in addition to the reducer.

SELECTION EXAMPLE. A belt conveyor, uniformly loaded, requires a direct coupled worm gear speed reducer to drive a light continuous belt. A 2 HP 1750 RPM electric motor is to be the prime move. Reducer output shaft must drive conveyor at approximately 115 RPM. The machine is expected to operate 24 hours per day.

STEP No. 1. Table 1 (page B-9) indicates service factor requirement of 1.25 for an electric motor drive under required 24 hour uniform load conditions.

STEP No. 2. Decide whether the application will require the reducer to be selected based on mechanical rating or thermal rating. Units may be selected based on mechanical rating only if the continuous operating period does not exceed two hours and shutdown period equals or exceeds operating period. Since our example requires 24 hours per day service the unit must be selected based on thermal capacity.

STEP No. 3. Calculate ratio required. Divide 1750 RPM input speed by 115 RPM required output speed. A 15:1 ratio is needed.

STEP No. 4. Refer to the Thermal Quick Selection Chart on (page B-14). Down the left side find the 15:1 ratio selection. Trail across this section on the 1.25 service factor line to the 2 HP column. The proper selection for this application is a No. 240PL Series standard unit. Thermal design options allow maximum flexibility in unit selection and application.

Additional rating information can be obtained by referring to the detailed rating data for each individual series. Rating data for each thermal design option is listed.

STEP No. 5. Refer to Model Selection Chart (page B-12) and select the applicable model. In the above example, it states a direct coupled reducer is required with output shaft extensions is the proper selection.

After the selection process has shown the correct series worm gear speed reducer required, then the specific data listed below is needed to properly place an order for each of the models within a series.

To order motorized reducers, specify the reducer as shown, indicate the motor description as shown and specify "motorized assembly."

	Model	Ratio	Style	Gear Type	Frame Size	Output Bore	Motor
	32	5	(L)	30/1 B	WR	143TC	1.437 C322 (B3)
UNIT SERIES							
	32						
	5						
	(L)						
	30/1 B						
	WR						
	143TC						
	1.437						
	C322						
	(B3)						
	MOUNTING POSITION Pre-lubrication units only (See Page B-13)						
	MOTOR See Section H for available motors						
	OUTPUT BORE (Applies to model numbers ending in 2,3,5 or 6 only) Refer to dimensional pages for output bore sizes available in each model						
	FRAME SIZE (Applies to model numbers ending in 4,5,6,8 or 0 only) Refer to dimensional pages for frame sizes available in each model						
	GEAR TYPE WR : Worm Right (standard) WL : Worm Left (mfg to order - consult factory)						
	OUTPUT STYLE Refer to dimensional pages for styles available in each model						
	RATIO Refer to ratings pages at the beginning of the single, double and triple reduction sections for ratios available in each model						

	SERIES	CENTER DISTANCE
13	130	1.33"
18	180	1.75"
21	210	2.06"
24	W240	2.38"
26	260	2.63"
32	320	3.25"
38	380	3.75"
45	450	4.50"
52	520	5.25"
GW60	60	6"
GW70	70	7"
GW80	80	8"
GW100	100	10"

MODEL CONFIGURATION
Refer to Features pages B-3 to B-6 or Model Index pages B-12, B-48 and B-78 for model configurations available in each series

Note:
For Double reduction models a zero (0) is inserted ahead of this number
For Triple reduction models a five (5) is inserted ahead of this number
(a six (6) for models ending in zero (0))

LUBRICATION
(Optional) Indicates unit is pre-lubricated with polyglycol lubrication. Mounting position must be specified (See Page B-13)



SINGLE REDUCTION

B

For Compact Light Weight Aluminum Worm Gear Drives
See Spartan™ Worm Gear Drives

Section C

For High Efficiency
Right Angle Gear Drives
See Poweratio® 2000
Helical Bevel and Helical Worm Units

Sections K & L

For Available Electric Motors

Section H

For Stainless Steel Worm Gear Drives
See HUB³™

Section O



MODEL INDEX

SERIES										
130	131 PAGE B-24,B-25			134 PAGE B-32,B-33						
180	181 PAGE B-24,B-25	182 PAGE B-26,B-27	183 PAGE B-28,B-29	184 PAGE B-32,B-33	185 PAGE B-34,B-35	186 PAGE B-36,B-37			189V SEE PAGE B-93	180V SEE PAGE B-40,B-41
210	211 PAGE B-24,B-25	212 PAGE B-26,B-27	213 PAGE B-28,B-29	214 PAGE B-32,B-33	215 PAGE B-34,B-35	216 PAGE B-36,B-37			219V SEE PAGE B-93	210V SEE PAGE B-93
W240	241 PAGE B-24,B-25	242 PAGE B-26,B-27	243 PAGE B-28,B-29	244 PAGE B-32,B-33	245 PAGE B-34,B-35	246 PAGE B-36,B-37			249V SEE PAGE B-93	240V SEE PAGE B-93
260	261 PAGE B-24,B-25	262 PAGE B-26,B-27	263 PAGE B-28,B-29	264 PAGE B-32,B-33	265 PAGE B-34,B-35	266 PAGE B-38,B-39			269V SEE PAGE B-93	260V SEE PAGE B-93
320	321 PAGE B-24,B-25	322 PAGE B-26,B-27	323 PAGE B-28,B-29	324 PAGE B-32,B-33	325 PAGE B-34,B-35	326 PAGE B-36,B-37	327 PAGE B-40,B-41	328 PAGE B-42,B-43	329V SEE PAGE B-93	320V SEE PAGE B-93
380	381 PAGE B-24,B-25	382 PAGE B-26,B-27	383 PAGE B-28,B-29	384 PAGE B-32,B-33	385 PAGE B-34,B-35	386 PAGE B-36,B-37	387 PAGE B-40,B-41	388 PAGE B-42,B-43	389V SEE PAGE B-93	380V SEE PAGE B-93
450	451 PAGE B-24,B-25	452 PAGE B-26,B-27	453 PAGE B-30,B-31	454 PAGE B-32,B-33	455 PAGE B-34,B-35	456 PAGE B-38,B-39	457 PAGE B-40,B-41	458 PAGE B-42,B-43	459V PAGE B-44,B-45	450V PAGE B-46,B-47
520	521 PAGE B-24,B-25	522 PAGE B-26,B-27	523 PAGE B-30,B-31	524 PAGE B-32,B-33	525 PAGE B-34,B-35	526 PAGE B-38,B-39	527 PAGE B-40,B-41	528 PAGE B-42,B-43	529V PAGE B-44,B-45	520V PAGE B-46,B-47
GW60	GW601 PAGE B-24,B-25	GW602 PAGE B-26,B-27		GW604 PAGE B-32,B-33	GW605 PAGE B-34,B-35		GW607 PAGE B-40,B-41	GW608 PAGE B-42,B-43		
GW70	GW701 PAGE B-24,B-25	GW702 PAGE B-26,B-27					GW707 PAGE B-40,B-41			
GW80	GW801 PAGE B-24,B-25	GW802 PAGE B-26,B-27					GW807 PAGE B-40,B-41			
GW100	GW1001 PAGE B-24,B-25	GW1002 PAGE B-26,B-27					GW1007 PAGE B-40,B-41			

FOR ACCESSORIES REFER TO PAGE B-87 TO B-97

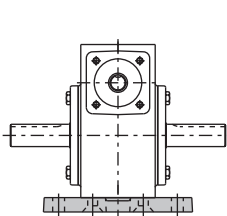

Universal
Base Kits

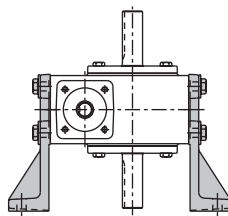

Side Mounting Kits

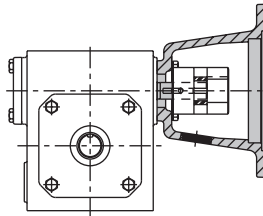

NEMA "C" Flange
Adaptor Kits

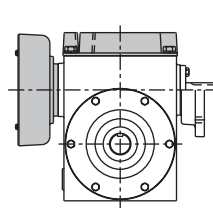

Fan Kits &
Thermal Block Kits

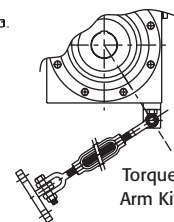

Torque
Arm Kit



MOUNTING POSITIONS FOR POWERCUBE AND POWERCUBE LUBE FILLED UNITS SERIES 130 - 380

B
SINGLE REDUCTION

NOTE: MOUNTING POSITION MUST BE SPECIFIED AND INDICATED IN REDUCER DESCRIPTION WHEN ORDERING PRE-LUBRICATED UNITS, SO THE CORRECT AMOUNT OF OIL IS INSTALLED AT THE FACTORY.
(REFER TO SECTION R FOR LUBRICATION INFORMATION.)

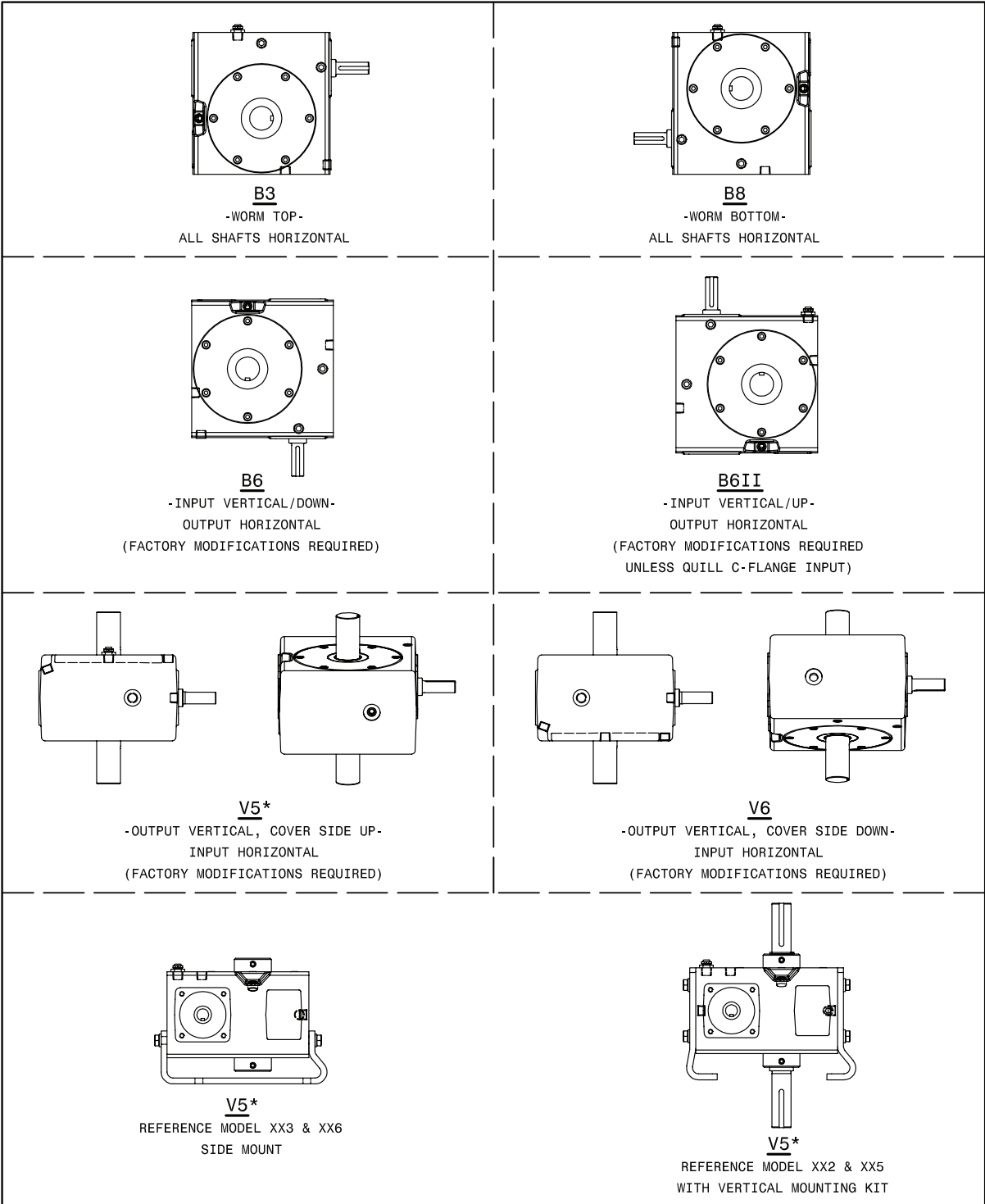

* V5 IS THE PREFERRED MOUNTING POSITION FOR VERTICAL OUTPUT
FACTORY MODIFICATIONS NOT REQUIRED WITH HIGH OIL LEVEL.



QUICK SELECTION CHART

CONTINUOUS DUTY RATING

SERIES TO NEAREST STANDARD MOTOR HP
 BASED ON BOTH MECHANICAL AND THERMAL CRITERIA

RATIO	OUTPUT RPM	SERVICE FACTOR	INPUT HORSEPOWER AT 1750 RPM												
			1/6 HP	1/4 HP	1/3 HP	1/2 HP	3/4 HP	1 HP	1 1/2 HP	2 HP	3 HP	5 HP	7 1/2 HP	10 HP	15 HP
5	350.0	1.00	130	130	130	130	130	130	180	180	240	260SL	320SL	320PL	380PL
		1.25	130	130	130	130	130	130	180	180PL	240SL	260PL	320PL	320PL	380PL
		1.50	130	130	130	130	130	180	180SL	210SL	240SL	320SL	320PL	380PL	GW60
		1.75	130	130	130	130	130	180	210	240	260PL	380	320PL	380PL	GW60
7.5	233.3	1.00	180	180	180	180	180	180	180	180PL	240SL			GW60	GW60
		1.25	180	180	180	180	180	180	180SL	240	240PL			GW60	GW60
		1.50	180	180	180	180	180	180	180SL	240PL				GW60	GW60
		1.75	180	180	180	180	180	180SL	240	240PL					GW60
10	175.0	1.00	130	130	130	130	130	180	210	240	260	380	450	520	520PL
		1.25	130	130	130	130	180	180SL	210SL	240	260SL	380SL	450SL	520SL	GW60
		1.50	130	130	130	130	180	180PL	210PL	240SL	260PL	380SL	450PL	520PL	GW60
		1.75	130	130	130	130SL	180SL	180PL	240	240PL	320PL	380PL	520SL	GW60	GW70
15	116.7	1.00	130	130	130	130	180	210	240	240SL	320	380SL	380PL	520PL	GW60
		1.25	130	130	130	130SL	180SL	210	240SL	240PL	320PL	380PL	520SL	GW60	GW60
		1.50	130	130	130	180	210	240	240PL	260PL	320PL	450PL	520PL	GW60	GW70
		1.75	130	130	130	180	210SL	240SL	240PL	260PL	320PL	450PL	GW60	GW60	GW80
20	87.5	1.00	130	130	130	130	180	210	240	260	380	450	520SL	GW60	GW60
		1.25	130	130	130	180	180SL	210SL	240	260SL	380SL	450PL	520PL	GW60	GW70
		1.50	130	130	130	180	210	210SL	260SL	320PL	380PL	520SL	GW60	GW60	GW80
		1.75	130	130	180	180SL	210SL	240	260PL	320PL	450SL	520PL	GW60	GW70	GW100
25	70.0	1.00	130	130	130	180	180SL	210	240	320	320PL	GW60	GW60	GW60	GW70
		1.25	130	130	130	180	180PL	210PL	260	320SL	320PL	GW60	GW60	GW60	GW80
		1.50	130	130	180	180SL	210SL	240	260SL	320PL		GW60	GW60	GW70	GW100
		1.75	130	130	180	180PL	210PL	260	320PL	320PL		GW60	GW70	GW70	GW100
30	58.3	1.00	130	130	130	180	240	260	320	380	450	520SL	GW60	GW60	GW80
		1.25	130	130	130SL	180SL	240	260SL	320SL	380SL	450PL	520PL	GW60	GW70	GW100
		1.50	130	130	180	180PL	240PL	260PL	320PL	380PL	450PL	GW60	GW70	GW80	GW100
		1.75	130	180	180SL	210SL	240PL	260PL	320PL	380PL	520PL	GW60	GW70	GW80	GW100
40	43.8	1.00	130	130	130	180	210SL	260	320SL	380	450SL	GW60	GW60	GW70	GW100
		1.25	130	130	180	180PL	240	260SL	320PL	380PL	450PL	GW60	GW70	GW80	GW100
		1.50	130	180	180	210SL	240SL	260PL	380SL	450SL	520PL	GW60	GW80	GW100	
		1.75	130	180	180SL	210PL	260SL	320PL	380PL	450PL	520PL	GW70	GW80	GW100	
50	35.0	1.00	130	130	180	210	240	260	380	380SL	520	GW60	GW70	GW80	GW100
		1.25	130	180	180	210	240	260SL	380SL	380PL	520SL	GW60	GW80	GW100	
		1.50	130	180	180SL	210PL	260SL	320PL	380PL	380PL	520PL	GW70	GW80	GW100	
		1.75	130	180	210	240	260PL	380	380PL	450PL	GW60	GW70	GW100	GW100	
60	29.2	1.00	130	180	180	210	260SL	320	380	450	520	GW60	GW80	GW100	
		1.25	130	180	180SL	210PL	260PL	320SL	380SL	450PL	520PL	GW60PL	GW100	GW100	
		1.50		180	210	240PL	260PL	320PL	380PL	450PL	520PL	GW80	GW100		
		1.75		180SL	210SL	260SL	320PL	380	450PL	520SL	GW60	GW80	GW100		
70	25.0	1.00									GW70	GW70	GW100	GW100	
		1.25										GW70	GW80	GW100	
		1.50										GW70	GW100	GW100	
		1.75										GW70	GW100		

PL: PAG (POLYALKALINE GLYCOL, ALSO KNOWN AS POLYGLYCOL LUBRICANT) INSTALLED
 SL: PAO (POLYALPHAOLEPHIN STANDARD SYNTHETIC LUBRICANT) INSTALLED

CONTINUED ON NEXT PAGE



QUICK SELECTION CHART

B

SINGLE REDUCTION

CONTINUOUS DUTY RATING (cont'd)

SERIES TO NEAREST STANDARD MOTOR HP
BASED ON BOTH MECHANICAL AND THERMAL CRITERIA

RATIO	OUTPUT RPM	SERVICE FACTOR	INPUT HORSEPOWER AT 1750 RPM				
			20 HP	25 HP	30 HP	40 HP	50 HP
5	350.0	1.00	GW60	GW60	GW60	GW70	GW70
		1.25	GW60	GW60	GW60	GW70	GW70
		1.50	GW60	GW70	GW70	GW80	GW100
		1.75	GW60	GW70	GW80	GW100	
7.5	233.3	1.00	GW60	GW60	GW60	GW70	GW80
		1.25	GW60	GW70	GW70	GW80	GW100
		1.50	GW60	GW70	GW80	GW100	GW100
		1.75	GW70	GW80	GW80	GW100	
10	175.0	1.00	GW60	GW60	GW70	GW80	GW100
		1.25	GW60	GW70	GW80	GW100	GW100
		1.50	GW70	GW80	GW100	GW100	
		1.75	GW70	GW100	GW100		
15	116.7	1.00	GW70	GW70	GW80	GW100	GW100
		1.25	GW70	GW80	GW100	GW100	
		1.50	GW70	GW80	GW100	GW100	
		1.75	GW100	GW100	GW100		
20	87.5	1.00	GW80	GW80	GW100	GW100	
		1.25	GW80	GW100	GW100		
		1.50	GW100	GW100			
		1.75	GW100				
25	70.0	1.00	GW80	GW100	GW100		
		1.25	GW100	GW100			
		1.50	GW100				
		1.75					
30	58.3	1.00	GW100	GW100			
		1.25	GW100				
		1.50					
		1.75					
40	43.8	1.00	GW100				

PL: PAG (POLYGLYCOL LUBRICANT INSTALLED)

SL: PAO (SYNTHETIC LUBRICANT INSTALLED)

FOR RATIOS HIGHER THAN SHOWN, CONTACT FACTORY

HUB CITY SERIES BY MECHANICAL OUTPUT TORQUE

1.00 SERVICE FACTOR AT 1750 RPM INPUT

FOR SERVICE FREE FROM SHOCK LOADING AND A TOTAL DURATION OF UP TO 10 HOURS PER DAY

RATIO	OUTPUT RPM	SERIES												
		130	180	210	240	260	320	380	450	520	GW60	GW70	GW80	GW100
5	350.0	220	450	597	801	1103	2200	3105			6068	9062	11866	18619
7.5	233.3		513	723	1026						7704	10572	13867	21413
10	175.0	266	550	770	1096	1551	2524	3757	5636	7991	8467	11893	14447	22466
15	116.7	294	576	820	1180	1601	2676	3839	6047	8607	9515	12827	16766	26308
20	87.5	295	607	828	1207	1707	2773	4204	6441	8800	10127	13431	17575	27597
25	70.0	291	625	870	1213	1714	2844				10245	13462	17578	27618
30	58.3	300	589	834	1209	1633	2708	3907	6176	8814	10249	13356	17166	27433
40	43.8	291	599	816	1195	1688	2780	4237	6372	8721	10203	13399	17507	27471
50	35.0	277	595	827	1152	1635	2832	6107	4052	8329	10079	13011	17028	26703
60	29.2	258	542	787	1069	1414	2841	3814	5708	7773	9808	12220	15982	25107
70	25.0										11300	14743	23235	



UNIVERSAL POWER CUBE CATALOG RATINGS

SERIES 130 & 180

	INPUT RPM	RATIO	OUTPUT RPM	MECH. INPUT HP	CONVENTIONAL OIL				PAO SYNTHETIC OIL				PAG SYNTHETIC OIL		
					EFF. %	MECH. OUTPUT TORQUE	THERMAL INPUT HP	THERMAL OUTPUT TORQUE	EFF. %	MECH. OUTPUT TORQUE	THERMAL INPUT HP	THERMAL OUTPUT TORQUE	EFF. %	INPUT HP	OUTPUT TORQUE
SERIES 130 RATINGS	1750	5	350.0	1.40	86.9	220	1.29	202	89.6	227	1.40	227	92.4	1.40	234
		10	175.0	.907	81.4	266	.819	240	84.4	276	.907	276	87.5	.907	286
		15	116.7	.707	77.0	294	.616	256	79.9	305	.707	305	83.2	.707	318
		20	87.5	.551	74.4	295	.551	295	77.2	306	.551	306	80.4	.551	319
		25	70.0	.459	70.3	291	.459	291	73.0	302	.459	302	76.0	.459	314
		30	58.3	.423	65.5	300	.386	273	68.7	314	.423	314	71.6	.423	327
		40	43.8	.327	61.8	291	.307	273	64.8	305	.327	305	67.5	.327	318
		50	35.0	.273	56.3	277	.273	277	59.0	290	.273	290	61.5	.273	303
	60	29.2	.232	51.4	258	.232	258	54.0	271	.232	271	56.5	.232	284	
	1150	5	230.0	1.09	85.5	255	1.09	255	88.3	264	1.09	264	91.0	1.09	272
		10	115.0	.700	79.4	305	.593	258	82.4	316	.700	316	85.4	.700	327
		15	76.7	.549	74.5	336	.549	336	77.3	349	.549	349	80.5	.549	363
		20	57.5	.425	71.6	334	.425	334	74.3	346	.425	346	77.4	.425	361
		25	46.0	.359	67.2	330	.359	330	69.8	343	.359	343	72.7	.359	357
		30	38.3	.335	62.0	342	.335	342	65.1	359	.335	359	67.8	.335	374
		40	28.8	.258	58.1	329	.258	329	61.0	345	.258	345	63.5	.258	360
		50	23.0	.219	52.3	314	.219	314	54.9	329	.219	329	57.2	.219	343
	60	19.2	.170	47.4	266	.170	266	49.8	279	.170	279	52.1	.170	292	
	100	5	20.0	.135	78.4	333	.135	333	80.9	344	.135	344	83.4	.135	355
		10	10.0	.089	69.6	388	.089	388	72.2	403	.089	403	74.8	.089	418
		15	6.7	.071	62.9	424	.071	424	65.3	440	.071	440	68.0	.071	458
		20	5.0	.055	59.4	414	.055	414	61.6	429	.055	429	64.2	.055	447
		25	4.0	.039	53.7	331	.039	331	55.7	344	.039	344	58.0	.039	358
		30	3.3	.048	47.7	430	.048	430	50.0	451	.048	451	52.1	.048	470
40		2.5	.037	43.6	406	.037	406	45.8	426	.037	426	47.7	.037	444	
50		2.0	.028	37.6	330	.028	330	39.5	346	.028	346	41.1	.028	360	
60	1.7	.021	32.9	266	.021	266	34.5	279	.021	279	36.1	.021	292		
SERIES 180 RATINGS	1750	5	350.0	2.85	87.6	450	2.04	322	90.4	464	2.40	390	93.2	2.85	478
		7.5	233.3	2.23	85.1	513	1.53	351	88.3	532	1.88	448	91.0	2.23	548
		10	175.0	1.85	82.6	550	1.22	364	85.7	571	1.50	464	88.8	1.85	591
		15	116.7	1.36	78.4	576	.916	388	81.4	598	1.13	495	84.8	1.36	623
		20	87.5	1.11	76.0	607	.822	450	78.9	630	1.01	573	82.2	1.11	656
		25	70.0	.960	72.3	625	.686	447	75.1	649	.818	553	78.2	.960	676
		30	58.3	.804	67.8	589	.556	407	71.1	618	.674	518	74.1	.804	644
		40	43.8	.649	64.1	599	.509	470	67.3	629	.618	599	70.1	.649	655
	1150	5	35.0	.560	58.9	595	.455	483	61.8	624	.524	583	64.4	.560	650
		60	29.2	.462	54.2	542	.384	450	56.9	568	.462	568	59.6	.462	595
		5	230.0	2.32	86.4	548	1.84	435	89.1	566	2.27	554	91.9	2.32	583
		7.5	153.3	1.80	83.5	618	1.15	394	86.6	642	1.78	633	89.3	1.80	661
		10	115.0	1.49	80.7	659	1.17	518	83.8	683	1.49	683	86.8	1.49	708
		15	76.7	1.10	76.0	685	.886	554	78.9	711	1.10	711	82.2	1.10	741
		20	57.5	.887	73.4	713	.796	640	76.1	740	.887	740	79.3	.887	771
		25	46.0	.777	69.2	737	.658	624	71.8	765	.777	765	74.8	.777	797
	100	30	38.3	.661	64.3	699	.555	587	67.5	733	.661	733	70.3	.661	764
		40	28.8	.531	60.5	703	.504	668	63.5	738	.531	738	66.1	.531	769
		50	23.0	.466	54.9	700	.437	658	57.6	735	.466	735	60.0	.466	765
		60	19.2	.390	50.0	641	.390	641	52.4	673	.390	673	54.9	.390	704
		5	20.0	.312	79.0	777	.312	777	81.5	802	.312	802	84.0	.312	826
		7.5	13.3	.242	74.7	855	.242	855	77.5	887	.242	887	79.9	.242	915
		10	10.0	.204	70.4	904	.204	904	73.1	938	.204	938	75.7	.204	972
		15	6.7	.156	62.9	930	.156	930	65.3	965	.156	965	68.0	.156	1005

ADDITIONAL RATINGS FOR OTHER INPUT SPEEDS ARE AVAILABLE AT WWW.HUBCITYINC.COM
 OVERHUNG LOAD - LOW SPEED SHAFT - MODELS 131 AND 134 225 LBS. AT CENTER POINT OF SHAFT EXTENSION.
 MODELS 181 AND 184 550 LBS. AT CENTER POINT OF SHAFT EXTENSION. MODELS 182 AND 185 NOT APPLICABLE.
 THRUST ‡ UP OR DOWN 600 LBS.
 †OHL AND THRUST VALUES SHOWN ARE INDEPENDENT FUNCTIONS AND CANNOT BE APPLIED SIMULTANEOUSLY.
 REFER APPLICATIONS WITH COMBINED OHL AND THRUST TO HUB CITY CUSTOMER SERVICE DEPARTMENT.



UNIVERSAL POWER CUBE CATALOG RATINGS

SERIES 210 & W240

		CONVENTIONAL OIL							PAO SYNTHETIC OIL				PAG SYNTHETIC OIL		
	INPUT RPM	RATIO ^	OUTPUT RPM	MECH. INPUT HP	EFF. %	MECH. OUTPUT TORQUE	THERMAL INPUT HP	THERMAL OUTPUT TORQUE	EFF. %	MECH. OUTPUT TORQUE	THERMAL INPUT HP	THERMAL OUTPUT TORQUE	EFF. %	INPUT HP	OUTPUT TORQUE
SERIES 210 RATINGS*	1750	5	350.0	3.77	88.0	597	2.80	443	90.8	616	3.32	543	93.6	3.77	635
		7.5	233.3	3.13	85.7	723	2.07	480	88.9	750	2.42	580	91.6	3.13	773
		10	175.0	2.57	83.1	770	1.74	520	86.3	799	2.05	637	89.4	2.57	828
		15	116.7	1.93	78.8	820	1.25	534	81.8	851	1.48	655	85.2	1.93	886
		20	87.5	1.50	76.7	828	1.14	629	79.6	859	1.35	772	82.9	1.50	895
		25	70.0	1.30	74.3	870	1.02	679	77.1	903	1.20	833	80.3	1.30	941
		30	58.3	1.13	68.2	834	.622	458	71.5	875	.874	675	74.5	1.13	912
		40	43.8	.872	65.0	816	.691	647	68.2	857	.808	793	71.0	.872	892
	50	35.0	.747	61.5	827	.632	700	64.5	868	.740	860	67.2	.747	904	
	60	29.2	.656	55.5	787	.524	629	58.3	826	.613	772	61.0	.656	865	
	1150	5	230.0	3.25	86.8	772	2.55	607	89.5	797	3.04	745	92.3	3.25	821
		7.5	153.3	2.64	84.1	912	1.62	560	87.2	946	1.93	690	89.9	2.64	975
		10	115.0	2.17	81.3	966	1.64	732	84.3	1003	1.98	916	87.4	2.17	1039
		15	76.7	1.64	76.3	1026	1.21	762	79.2	1065	1.43	934	82.5	1.64	1110
		20	57.5	1.25	73.9	1014	1.10	895	76.7	1052	1.25	1052	79.9	1.25	1096
		25	46.0	1.02	71.2	993	1.02	993	73.9	1030	1.02	1030	77.0	1.02	1073
		30	38.3	.983	64.5	1042	.752	798	67.7	1093	.880	979	70.5	.983	1139
		40	28.8	.746	61.1	1000	.702	940	64.1	1049	.746	1049	66.8	.746	1093
	50	23.0	.627	57.5	987	.627	987	60.3	1035	.627	1035	62.8	.627	1078	
	60	19.2	.532	51.2	896	.532	896	53.8	941	.532	941	56.3	.532	985	
	100	5	20.0	.488	78.9	1212	.488	1212	81.4	1250	.488	1250	83.9	.488	1289
		7.5	13.3	.387	74.8	1369	.387	1369	77.6	1420	.387	1420	80	.387	1464
		10	10.0	.325	70.3	1439	.325	1439	73.0	1493	.325	1493	75.6	.325	1547
		15	6.7	.256	62.9	1519	.256	1519	65.3	1577	.256	1577	68.0	.256	1642
20		5.0	.168	59.8	1270	.168	1270	62.1	1318	.168	1318	64.7	.168	1373	
25		4.0	.111	56.6	993	.111	993	58.8	1030	.111	1030	61.2	.111	1073	
30		3.3	.171	47.5	1537	.171	1537	49.8	1613	.171	1613	51.9	.171	1680	
40		2.5	.128	44.1	1424	.128	1424	46.3	1494	.128	1494	48.2	.128	1557	
50	2.0	.077	40.5	987	.077	987	42.5	1035	.077	1035	44.3	.077	1078		
60	1.7	.070	33.9	896	.070	896	35.5	941	.070	941	37.2	.070	985		
SERIES W240 RATINGS**	1750	5	350	5.01	88.7	801	3.70	591	91.6	826	4.50	742	94.4	5.01	852
		7.5	233	4.36	87.2	1026	2.65	624	90.5	1065	3.08	754	93.3	4.36	1098
		10	175	3.54	85.8	1096	2.85	880	89.1	1137	3.43	1100	92.3	3.54	1178
		15	117	2.64	82.8	1180	1.73	775	85.9	1224	2.09	968	89.5	2.64	1275
		20	87.5	2.09	80.3	1207	1.89	1093	83.3	1253	2.09	1253	86.8	2.09	1305
		25	70.0	1.72	78.3	1213	1.70	1201	81.2	1259	1.72	1259	84.6	1.72	1311
		30	58.3	1.50	74.7	1209	.94	756	78.3	1269	1.12	945	81.6	1.50	1322
		40	43.8	1.18	70.5	1195	.99	1010	74.0	1254	1.18	1254	77.1	1.18	1306
	50	35.0	.95	67.3	1152	.95	1152	70.7	1209	.95	1209	73.6	.95	1259	
	60	29.2	.76	65.3	1069	.58	814	68.6	1122	.69	1017	71.8	.76	1175	
	1150	5	230	4.26	87.7	1025	3.35	804	90.5	1058	4.00	993	93.3	4.26	1090
		7.5	153	3.57	86.0	1262	2.06	728	89.2	1310	2.45	897	92.0	3.57	1350
		10	115	2.83	84.4	1309	2.68	1240	87.6	1358	3.67	1761	90.8	2.83	1407
		15	76.7	2.10	81.0	1399	1.66	1109	84.1	1452	2.10	1452	87.6	2.10	1513
		20	57.5	1.66	78.2	1426	1.66	1426	81.1	1480	1.66	1480	84.5	1.66	1541
		25	46.0	1.37	75.9	1420	1.37	1420	78.7	1474	1.37	1474	82.0	1.37	1535
		30	38.3	1.21	71.9	1428	.92	1089	75.5	1498	1.10	1362	78.6	1.21	1560
		40	28.8	.95	67.3	1407	.95	1407	70.7	1476	.95	1476	73.6	.95	1538
	50	23.0	.77	63.9	1347	.77	1347	67.0	1414	.77	1414	69.8	.77	1472	
	60	19.2	.58	61.9	1171	.58	1171	64.9	1229	.58	1229	68.0	.58	1287	
	100	5	20	.62	80.7	1577	.62	1577	83.3	1627	.62	1627	85.9	.62	1678
		7.5	13	.49	78.6	1812	.49	1812	81.6	1879	.49	1879	84.1	.49	1938
		10	10.0	.37	76.8	1784	.37	1784	79.7	1851	.37	1851	82.6	.37	1919
		15	6.7	.28	71.5	1886	.28	1886	74.2	1957	.28	1957	77.3	.28	2038
20		5.0	.225	67.2	1905	.225	1905	69.7	1977	.225	1977	72.6	.225	2060	
25		4.0	.148	63.9	1493	.148	1493	66.3	1549	.148	1549	69.1	.148	1614	
30		3.3	.172	58.7	1909	.172	1909	61.5	2002	.172	2002	64.1	.172	2086	
40		2.5	.141	52.8	1873	.141	1873	55.4	1965	.141	1965	57.7	.141	2047	
50	2.0	.097	48.8	1487	.097	1487	51.2	1560	.097	1560	53.3	.097	1626		
60	1.7	.066	47.2	1171	.066	1171	49.6	1229	.066	1229	51.9	.066	1287		

^7.5/1 RATIO IS MANUFACTURED TO ORDER. CONSULT FACTORY FOR PRICE AND AVAILABILITY

ADDITIONAL RATINGS FOR OTHER INPUT SPEEDS ARE AVAILABLE AT WWW.HUBCITYINC.COM

*OVERHUNG LOAD - LOW SPEED SHAFT – MODELS 211 AND 214 550 LBS. AT CENTER POINT OF SHAFT EXTENSION. MODELS 212 AND 215 NOT APPLICABLE. THRUST ‡ UP OR DOWN 600 LBS.

**OVERHUNG LOAD - LOW SPEED SHAFT – MODELS 241 AND 244 1150 LBS. AT CENTER POINT OF SHAFT EXTENSION. MODELS 242 AND 245 NOT APPLICABLE. THRUST ‡ UP OR DOWN 1000 LBS.

‡OHL AND THRUST VALUES SHOWN ARE INDEPENDENT FUNCTIONS AND CANNOT BE APPLIED SIMULTANEOUSLY. REFER APPLICATIONS WITH COMBINED OHL AND THRUST TO HUB CITY CUSTOMER SERVICE DEPARTMENT.



UNIVERSAL POWER CUBE CATALOG RATINGS

SERIES 260 & 320

	INPUT RPM	RATIO	OUTPUT RPM	MECH. INPUT HP	CONVENTIONAL OIL				PAO SYNTHETIC OIL				PAG SYNTHETIC OIL		
					EFF. %	MECH. OUTPUT TORQUE	THERMAL INPUT HP	THERMAL OUTPUT TORQUE	EFF. %	MECH. OUTPUT TORQUE	THERMAL INPUT HP	THERMAL OUTPUT TORQUE	EFF. %	INPUT HP	OUTPUT TORQUE
SERIES 260 RATINGS*	1750	5	350.0	6.91	88.6	1103	4.21	672	91.5	1139	5.12	843	94.3	6.91	1174
		10	175.0	5.04	85.47	1551	3.25	1000	88.7	1609	3.91	1250	91.9	5.04	1668
		15	116.7	3.67	80.8	1601	2.01	880	83.9	1661	2.43	1100	87.4	3.67	1731
		20	87.5	2.97	79.7	1707	2.16	1242	82.8	1772	2.60	1553	86.2	2.97	1846
		25	70.0	2.43	78.4	1714	1.93	1365	81.4	1779	2.33	1706	84.8	2.43	1853
		30	58.3	2.12	71.3	1633	1.12	859	74.8	1713	1.33	1074	77.9	2.12	1784
		40	43.8	1.68	69.6	1688	1.14	1148	73.1	1771	1.36	1435	76.1	1.68	1844
		50	35.0	1.34	67.6	1635	1.11	1352	70.9	1715	1.32	1690	73.9	1.34	1787
	60	29.2	1.12	58.4	1414	.733	925	61.3	1484	.873	1156	64.2	1.12	1554	
	1150	5	230.0	5.79	87.5	1389	3.81	914	90.3	1433	4.56	1129	93.1	5.79	1478
		10	115.0	4.23	84.0	1948	3.06	1409	87.1	2021	3.69	1761	90.3	4.23	2094
		15	76.7	3.22	78.6	2082	1.95	1260	81.6	2161	2.35	1575	85.0	3.22	2251
		20	57.5	2.50	77.4	2125	2.06	1752	80.4	2206	2.49	2190	83.7	2.50	2298
		25	46.0	1.81	76.0	1883	1.81	1883	78.9	1955	1.81	1955	82.2	1.81	2036
		30	38.3	1.89	68.0	2118	1.11	1238	71.3	2222	1.32	1548	74.3	1.89	2314
		40	28.8	1.45	66.2	2096	1.14	1658	69.4	2199	1.36	2073	72.3	1.45	2291
		50	23.0	1.07	64.1	1887	1.07	1887	67.3	1980	1.07	1980	70.1	1.07	2062
	60	19.2	1.03	54.1	1833	.769	1370	56.8	1923	.917	1713	59.5	1.03	2014	
	100	5	20.0	.986	79.5	2470	.986	2470	82.1	2549	.986	2549	84.6	.986	2628
		10	10.0	.613	75.1	2901	.613	2901	77.9	3010	.613	3010	80.7	.613	3119
		15	6.7	.531	65.8	3301	.531	3301	68.3	3426	.531	3426	71.1	.531	3569
		20	5.0	.382	64.8	3119	.382	3119	67.2	3237	.382	3237	70.0	.382	3371
		25	4.0	.189	63.3	1883	.189	1883	65.7	1955	.189	1955	68.4	.189	2036
		30	3.3	.347	50.9	3338	.347	3338	53.4	3502	.347	3502	55.6	.347	3648
40		2.5	.225	49.7	2823	.225	2823	52.1	2962	.225	2962	54.3	.225	3085	
50		2.0	.125	48.0	1887	.125	1887	50.4	1980	.125	1980	52.5	.125	2062	
60	1.7	.157	35.4	2102	.157	2102	37.1	2206	.157	2206	38.9	.157	2310		
SERIES 320 RATINGS**	1750	5	350.0	13.7	89.5	2200	6.99	1127	92.3	2270	8.27	1375	95.2	13.7	2340
		10	175.0	8.19	85.6	2524	3.99	1229	88.8	2619	4.69	1499	92.0	8.19	2714
		15	116.7	6.01	82.4	2676	3.05	1357	85.5	2778	3.58	1656	89.1	6.01	2893
		20	87.5	4.82	79.9	2773	2.49	1433	82.9	2878	2.93	1748	86.4	4.82	2998
		25	70.0	4.07	77.6	2844	2.13	1489	80.5	2951	2.50	1817	83.9	4.07	3074
		30	58.3	3.39	73.8	2708	1.69	1349	77.5	2842	1.97	1646	80.7	3.39	2960
		40	43.8	2.76	69.8	2780	1.41	1421	73.2	2917	1.64	1734	76.3	2.76	3039
		50	35.0	2.37	66.2	2832	1.23	1470	69.5	2971	1.43	1793	72.4	2.37	3095
	60	29.2	2.10	62.6	2841	1.10	1494	65.7	2982	1.28	1823	68.8	2.10	3122	
	1150	5	230.0	11.3	88.5	2741	6.22	1510	91.4	2828	7.36	1842	94.2	11.3	2916
		10	115.0	6.83	84.1	3145	3.75	1729	87.2	3263	4.41	2109	90.4	6.83	3381
		15	76.7	5.04	80.5	3334	2.94	1944	83.5	3460	3.45	2372	87.0	5.04	3605
		20	57.5	4.07	77.6	3462	2.33	1986	80.5	3593	2.74	2423	83.9	4.07	3742
		25	46.0	3.43	74.8	3517	2.07	2118	77.7	3650	2.43	2584	80.9	3.43	3802
		30	38.3	2.89	70.7	3356	1.65	1922	74.2	3522	1.92	2345	77.3	2.89	3668
		40	28.8	2.37	66.2	3447	1.41	2045	69.5	3617	1.64	2495	72.4	2.37	3768
		50	23.0	2.05	62.3	3507	1.27	2170	65.4	3679	1.48	2647	68.1	2.05	3833
	60	19.2	1.84	58.5	3531	1.15	2204	61.4	3706	1.33	2689	64.3	1.84	3880	
	100	5	20.0	2.11	81.5	5409	2.11	5409	84.1	5582	2.11	5582	86.7	2.11	5754
		10	10.0	1.33	73.8	6199	1.33	6199	76.6	6432	1.33	6432	79.4	1.33	6665
		15	6.7	1.02	67.9	6551	1.02	6551	70.5	6799	1.02	6799	73.4	1.02	7082
		20	5.0	.701	63.3	5591	.701	5591	65.7	5802	.701	5802	68.4	.701	6044
		25	4.0	.460	59.2	4292	.460	4292	61.4	4454	.460	4454	64.0	.460	4640
		30	3.3	.655	53.5	6627	.655	6627	56.2	6952	.655	6952	58.5	.655	7242
40		2.5	.463	47.9	5584	.463	5584	50.2	5858	.463	5858	52.3	.463	6103	
50		2.0	.313	43.3	4273	.313	4273	45.4	4484	.313	4484	47.3	.313	4670	
60	1.7	.232	39.3	3445	.232	3445	41.3	3615	.232	3615	43.2	.232	3785		

ADDITIONAL RATINGS FOR OTHER INPUT SPEEDS ARE AVAILABLE AT WWW.HUBCITYINC.COM

*OVERHUNG LOAD - LOW SPEED SHAFT – MODELS 261 AND 264 1150 LBS. AT CENTER POINT OF SHAFT EXTENSION. MODELS 262 AND 265 NOT APPLICABLE. THRUST‡ UP OR DOWN 1000 LBS.

**OVERHUNG LOAD - LOW SPEED SHAFT – MODELS 321 AND 324 1,100 LBS. AT CENTER POINT OF SHAFT EXTENSION. MODELS 322 AND 325 NOT APPLICABLE. MODELS 327 AND 328 – †OHL 1,280 LBS., TO‡ THRUST OUT 1,790 LBS. AND T† THRUST IN 1,210 LBS. THRUST‡ UP OR DOWN 1,200 LBS.

†OHL AND THRUST VALUES SHOWN ARE INDEPENDENT FUNCTIONS AND CANNOT BE APPLIED SIMULTANEOUSLY. REFER APPLICATIONS WITH COMBINED OHL AND THRUST TO HUB CITY CUSTOMER SERVICE DEPARTMENT.



UNIVERSAL POWER CUBE CATALOG RATINGS

SERIES 380

	INPUT RPM	RATIO	OUTPUT RPM	MECH. INPUT HP	CONVENTIONAL OIL			PAO SYNTHETIC OIL				PAG SYNTHETIC OIL			
					EFF. %	MECH. OUTPUT TORQUE	THERMAL INPUT HP	THERMAL OUTPUT TORQUE	EFF. %	MECH. OUTPUT TORQUE	THERMAL INPUT HP	THERMAL OUTPUT TORQUE	EFF. %	INPUT HP	OUTPUT TORQUE
SERIES 380 RATINGS	1750	5	350.0	19.2	89.9	3105	10.1	1631	92.7	3204	12.2	2039	95.6	19.2	3303
		10	175.0	12.1	86.5	3757	6.20	1931	89.7	3898	7.47	2414	93.0	12.1	4039
		15	116.7	8.53	83.3	3839	4.30	1937	86.5	3984	5.18	2422	90.1	8.53	4151
		20	87.5	7.15	81.6	4204	3.66	2153	84.7	4363	4.41	2691	88.2	7.15	4545
		30	58.3	4.80	75.4	3907	2.39	1943	79.1	4099	2.84	2429	82.4	4.80	4270
		40	43.8	4.06	72.5	4237	2.06	2153	76.0	4445	2.46	2691	79.2	4.06	4631
		50	35.0	3.24	69.4	4052	1.82	2278	72.9	4251	2.17	2847	75.9	3.24	4428
	60	29.2	2.66	66.2	3814	1.74	2493	69.5	4002	2.07	3117	72.8	2.66	4191	
	1150	5	230.0	15.9	89.0	3885	8.58	2093	91.9	4009	8.23	2617	94.7	15.9	4133
		10	115.0	9.93	85.1	4632	5.39	2512	88.3	4806	6.49	3140	91.5	9.93	4980
		15	76.7	7.15	81.6	4798	3.91	2622	84.7	4980	4.71	3278	88.2	7.15	5187
		20	57.5	6.03	79.55	5258	3.41	2975	82.6	5457	4.11	3719	86	6.03	5684
		30	38.3	4.08	72.6	4865	2.26	2694	76.1	5105	2.69	3367	79.3	4.08	5317
		40	28.8	3.47	69.3	5275	2.02	3060	72.7	5535	2.40	3825	75.7	3.47	5765
		50	23.0	2.79	65.9	5035	1.91	3444	69.1	5282	2.27	4305	72.0	2.79	5502
	60	19.2	2.29	62.4	4702	1.66	3408	65.5	4935	1.98	4260	68.6	2.29	5167	
	100	5	20.0	2.99	82.3	7755	2.99	7755	85.0	8002	2.99	8002	87.6	2.99	8250
		10	10.0	1.87	75.6	8904	1.87	8904	78.5	9239	1.87	9239	81.3	1.87	9574
		15	6.7	1.43	69.6	9412	1.43	9412	72.2	9768	1.43	9768	75.2	1.43	10175
		20	5.0	.916	66.3	7656	.916	7656	68.8	7946	.916	7946	71.7	.916	8277
		30	3.3	.903	55.8	9524	.903	9524	58.6	9993	.903	9993	61.0	.903	10409
		40	2.5	.591	51.6	7684	.591	7684	54.1	8062	.591	8062	56.4	.591	8398
		50	2.0	.391	47.6	5866	.391	5866	49.9	6155	.391	6155	52.0	.391	6411
		60	1.7	.284	43.8	4702	.284	4702	45.9	4935	.284	4935	48.1	.284	5167

ADDITIONAL RATINGS FOR OTHER INPUT SPEEDS ARE AVAILABLE AT WWW.HUBCITYINC.COM

OVERHUNG LOAD - LOW SPEED SHAFT –

MODELS 381 AND 384 1,600 LBS. AT CENTER POINT OF SHAFT EXTENSION.

MODELS 382 AND 385 NOT APPLICABLE.

MODELS 387 AND 388 – OHL* 1,970 LBS., TO* THRUST OUT 1,950 LBS. AND TI* THRUST IN 1,500 LBS.

THRUST* UP OR DOWN 1,500 LBS.

*OHL AND THRUST VALUES SHOWN ARE INDEPENDENT FUNCTIONS AND CANNOT BE APPLIED SIMULTANEOUSLY.

REFER APPLICATIONS WITH COMBINED OHL AND THRUST TO HUB CITY CUSTOMER SERVICE DEPARTMENT.

B

SINGLE REDUCTION



CENTURY SERIES CATALOG RATINGS

SERIES 450 & 520

	INPUT RPM	RATIO	OUTPUT RPM	MECH. INPUT HP	CONVENTIONAL OIL				PAO SYNTHETIC OIL				PAG SYNTHETIC OIL			
					EFF. %	MECH. OUTPUT TORQUE	THERMAL INPUT HP	THERMAL OUTPUT TORQUE	EFF. %	MECH. OUTPUT TORQUE	THERMAL INPUT HP	THERMAL OUTPUT TORQUE	EFF. %	MECH. OUTPUT TORQUE	THERMAL INPUT HP	THERMAL OUTPUT TORQUE
SERIES 450 RATINGS*	1750	10	175.0	18.0	87.1	5636	8.71	2732	90.4	5849	9.65	3142	93.7	6061	12.5	4207
		15	116.7	13.3	84.4	6047	6.01	2739	87.6	6276	6.66	3150	91.2	6538	8.93	4397
		20	87.5	10.8	82.8	6441	5.09	3034	85.9	6685	5.64	3489	89.5	6964	7.48	4822
		30	58.3	7.42	77.0	6176	3.20	2663	80.8	6480	3.51	3063	84.2	6750	4.97	4522
		40	43.8	5.95	74.4	6372	2.82	3018	78.0	6685	3.09	3470	81.3	6964	4.20	4919
		50	35.0	4.74	71.6	6107	1.77	2278	75.1	6407	1.94	2620	78.2	6674	3.60	5073
	1150	60	29.2	3.85	68.6	5708	2.18	3230	72.0	5991	2.39	3715	75.4	6273	3.19	5202
		10	115.0	14.7	85.9	6933	7.32	3445	89.2	7194	8.11	3962	92.4	7455	10.3	5233
		15	76.7	11.0	82.7	7476	5.27	3583	85.8	7759	5.84	4121	89.4	8082	7.41	5445
		20	57.5	9.08	80.9	8057	4.60	4080	84.0	8362	5.10	4692	87.5	8710	6.28	6026
		30	38.3	6.26	74.4	7658	3.02	3696	78.0	8035	3.31	4251	81.3	8370	4.20	5614
		40	28.8	5.10	71.4	7981	2.67	4181	74.9	8373	2.93	4809	78.0	8722	3.57	6104
	100	50	23.0	4.11	68.3	7680	1.84	3444	71.6	8058	2.02	3961	74.6	8393	3.09	6321
		60	19.2	3.36	65.1	7195	2.18	4666	68.3	7551	2.39	5365	71.5	7907	2.76	6479
		10	10.0	2.87	76.8	13897	2.87	13897	79.7	14420	2.87	14420	82.6	14943	2.87	14943
		15	6.7	2.19	71.1	14697	2.19	14697	73.8	15253	2.19	15253	76.9	15888	2.19	15888
		20	5.0	1.50	68.2	12924	1.50	12924	70.8	13307	1.50	13307	73.7	13972	1.50	13972
		30	3.3	1.36	57.8	14876	1.36	14876	60.7	15607	1.36	15607	63.2	16257	1.36	16257
SERIES 520 RATINGS**	1750	40	2.5	.957	53.9	13008	.957	13008	56.5	13647	.957	13647	58.9	14216	.957	14216
		50	2.0	.631	49.9	9919	.631	9919	52.3	10407	.631	10407	54.5	10840	.631	10840
		60	1.7	.454	46.1	7915	.454	7915	48.4	8307	.454	8307	50.7	8698	.454	8698
		10	175.0	25.3	87.7	7991	12.5	3941	91.0	8292	13.8	4532	94.3	8593	17.6	5987
		15	116.7	18.7	85.3	8607	8.80	4055	88.5	8932	9.75	4663	92.2	9305	12.9	6417
		20	87.5	14.6	83.9	8800	7.41	4476	87.1	9133	8.21	5147	90.7	9513	10.8	7059
	1150	30	58.3	10.4	78.6	8814	4.73	4018	82.5	9248	5.19	4621	85.9	9633	7.13	6614
		40	43.8	7.93	76.3	8721	4.04	4446	80.1	9150	4.43	5113	83.4	9531	6.05	7273
		50	35.0	6.27	73.7	8329	3.47	4606	77.4	8739	3.80	5297	80.6	9103	5.18	7518
		60	29.2	5.06	71.0	7773	3.20	4905	74.5	8157	3.50	5640	78.1	8542	4.58	7721
		10	115.0	21.4	86.7	10156	11.0	5205	89.9	10538	12.1	5986	93.2	10921	14.8	7548
		15	76.7	15.9	83.8	10939	7.51	5176	87.0	11353	8.33	5953	90.6	11826	10.7	7962
	100	20	57.5	12.1	82.2	10945	6.50	5857	85.3	11360	7.20	6735	88.9	11833	9.05	8821
		30	38.3	8.64	76.2	10833	4.25	5329	80.0	11365	4.66	6128	83.3	11839	6.02	8241
		40	28.8	6.74	73.6	10872	3.79	6105	77.2	11406	4.15	7021	80.4	11882	5.13	9036
		50	23.0	5.40	70.6	10443	3.49	6753	74.1	10956	3.82	7766	77.2	11413	4.41	9323
		60	19.2	4.40	67.6	9778	3.05	6786	71.0	10261	3.34	7804	74.3	10745	3.91	9553
		10	10.0	4.12	78.2	20328	4.12	20328	81.2	21093	4.12	21093	84.1	21858	4.12	21858
100	15	6.7	3.11	73.1	21509	3.11	21509	75.8	22323	3.11	22323	79.0	23253	3.11	23253	
	20	5.0	2.14	70.4	19019	2.14	19019	73.1	19739	2.14	19739	76.1	20561	2.14	20561	
	30	3.3	1.90	60.5	21779	1.90	21779	63.5	22850	1.90	22850	66.1	23802	1.90	23802	
	40	2.5	1.34	56.8	19261	1.34	19261	59.6	20208	1.34	20208	62.1	21050	1.34	21050	
	50	2.0	.875	52.9	14588	.875	14588	55.5	15305	.875	15305	57.8	15943	.875	15943	
	60	1.7	.621	49.3	11584	.621	11584	51.8	12157	.621	12157	54.2	12730	.621	12730	

CENTURY SERIES CONTINUED ON NEXT PAGE

ADDITIONAL RATINGS FOR OTHER INPUT SPEEDS ARE AVAILABLE AT WWW.HUBCITYINC.COM

*OVERHUNG LOAD - LOW SPEED SHAFT – MODELS 451 AND 454 2,200 LBS. AT CENTER POINT OF SHAFT EXTENSION. MODELS 452, 453, 455, AND 456 NOT APPLICABLE. MODELS 457 AND 458 – OHL† 2,370 LBS., TO‡ THRUST OUT 3,330 LBS. AND TI‡ THRUST IN 3,140 LBS. MODELS 459V AND 450V 2,000 LBS. AT CENTER POINT OF SHAFT EXTENSION. THRUST‡ UP OR DOWN 2,500 LBS.

**OVERHUNG LOAD - LOW SPEED SHAFT – MODELS 521 AND 524 2,600 LBS. AT CENTER POINT OF SHAFT EXTENSION. MODELS 522, 523, 525, AND 526 NOT APPLICABLE. MODELS 527 AND 528 – OHL† 3,550 LBS., TO‡ THRUST OUT 4,530 LBS. AND TI‡ THRUST IN 3,360 LBS. MODELS 529V AND 520V 2,300 LBS. AT CENTER POINT OF SHAFT EXTENSION. THRUST‡ UP OR DOWN 3,000 LBS.

†OHL AND THRUST VALUES SHOWN ARE INDEPENDENT FUNCTIONS AND CANNOT BE APPLIED SIMULTANEOUSLY. REFER APPLICATIONS WITH COMBINED OHL AND THRUST TO HUB CITY CUSTOMER SERVICE DEPARTMENT.

+ THERMAL RATINGS MAY BE INCREASED BY USING A THERMAL BLOCK KIT (PAGE B-94). CONSULT FACTORY FOR RATINGS.



GW SERIES CATALOG RATINGS

B

SINGLE REDUCTION

SERIES GW60

					CONVENTIONAL OIL		PAO SYNTHETIC OIL		PAG SYNTHETIC OIL		
					EFF. %	MECH. OUTPUT TORQUE	EFF. %	MECH. OUTPUT TORQUE	EFF. %	MECH. OUTPUT TORQUE	
SERIES GW60 RATINGS***	INPUT RPM	RATIO	OUTPUT RPM	MECH. INPUT HP							
	1750	5		341.5	35.1	96.0	6068	96.9	6129	97.9	6189
		7.5		236.5	29.9	95.1	7704	96.5	7820	97.5	7897
		10		179.5	24.9	94.0	8467	96.4	8679	97.3	8763
		15		119.3	19.2	91.5	9515	93.8	9753	95.2	9896
		20		85.4	15.7	89.5	10127	91.7	10380	93.5	10583
		25		71.4	13.0	87.1	10245	89.3	10501	91.0	10706
		30		59.3	11.1	84.8	10249	86.9	10505	88.6	10710
		40		43.8	8.72	81.2	10203	83.2	10458	84.8	10662
		50		35	7.24	77.2	10079	79.2	10331	80.7	10533
		60		29.2	6.15	73.7	9808	75.6	10053	77.1	10249
	80		21.9	3.70	68.1	7264	69.8	7446	71.1	7591	
	100		17.5	2.57	63.5	5886	65.1	6033	66.4	6151	
	1170	5		228.3	29.9	95.8	7726	96.7	7803	97.7	7881
		7.5		158.1	25.4	94.8	9740	96.3	9886	97.2	9984
		10		120	21.1	93.7	10687	96.0	10954	97.0	11061
		15		79.8	16.3	91.1	11996	93.3	12296	94.7	12476
		20		57.1	13.3	88.8	12758	91.1	13077	92.8	13332
		25		47.8	11.0	86.3	12903	88.5	13226	90.2	13484
		30		39.7	9.50	84.0	12911	86.1	13234	87.8	13492
		40		29.3	7.43	80.2	12848	82.2	13169	83.8	13426
		50		23.4	6.18	76.1	12691	78.0	13008	79.5	13262
		60		19.5	5.26	72.5	12352	74.3	12661	75.8	12908
	80.0		14.6	3.31	64.0	9142	65.6	9371	66.8	9553	
	100		11.7	2.32	59.2	7408	60.7	7593	61.9	7741	
	100	5		19.5	6.20	89.9	17587	90.8	17763	91.7	17939
		7.5		13.5	5.01	87.1	20662	88.4	20972	89.2	21179
		10		10.3	4.19	84.3	22324	86.4	22882	87.3	23105
		15		6.8	3.33	78.6	24797	80.5	25417	81.7	25789
		20		4.9	2.80	74.0	26194	75.9	26849	77.4	27373
		25		4.1	2.41	69.4	26436	71.1	27097	72.5	27626
		30		3.4	2.14	65.3	26480	66.9	27142	68.2	27672
		40		2.5	1.76	59.1	26260	60.6	26917	61.8	27442
50			2	1.54	53.3	25925	54.6	26573	55.7	27092	
60			1.7	1.37	48.6	25283	49.8	25915	50.8	26421	
80		1.3	0.95	40.2	19249	41.2	19730	42.0	20115		
100		1	0.68	35.5	15389	36.4	15774	37.1	16082		

NOTE: ALL TORQUE VALUES LISTED IN INCH-POUNDS, ALL OVERHUNG LOAD VALUES LISTED IN POUNDS. THE POINT OF APPLICATION OF THE OVERHUNG LOAD IS CONSIDERED TO BE ONE SHAFT DIAMETER MEASURED OUTWARD FROM THE GEAR CASE HOUSING. AT SPEEDS ABOVE 1750 RPM, UNITS MAY BECOME THERMALLY LIMITED. FOR EXTENDED OPERATION, LIMIT INPUT HP TO 1750 RPM CATALOG RATING.

Thrust and Overhung Load Ratings (Lbs.)	GW60
Thrust Load Ratings (Low Speed Shaft, All Ratios)	3990
Overhung Load Capacity* (High Speed Shaft, All Ratios)	450
Overhung Load Capacity* (Low Speed Shaft, All Ratios)	3723
Overhung Load Capacity** (Extended Brg Design Output Shaft, All Ratios)	2245

*OHL AND THRUST VALUES SHOWN ARE INDEPENDENT FUNCTIONS AND CANNOT BE APPLIED SIMULTANEOUSLY. REFER APPLICATIONS WITH COMBINED OHL AND THRUST TO HUB CITY CUSTOMER SERVICE DEPARTMENT.

**THE POINT OF APPLICATION OF THE OVERHUNG LOAD IS CONSIDERED TO BE ONE SHAFT DIAMETER MEASURED OUTWARD FROM THE GEARCASE HOUSING.

**LOAD LOCATED AT END OF OUTPUT SHAFT.

ADDITIONAL RATINGS FOR OTHER INPUT SPEEDS ARE AVAILABLE AT WWW.HUBCITYINC.COM



GW SERIES CATALOG RATINGS

SERIES GW70 & GW80

					CONVENTIONAL OIL		PAO SYNTHETIC OIL		PAG SYNTHETIC OIL	
	INPUT RPM	RATIO	OUTPUT RPM	MECH. INPUT HP	EFF. %	MECH. OUTPUT TORQUE	EFF. %	MECH. OUTPUT TORQUE	EFF. %	MECH. OUTPUT TORQUE
					SERIES GW70 RATINGS					
	1750	5	341.5	51.2	96.0	9062	96.9	9153	97.9	9243
		7.5	236.5	41.5	95.5	10572	97.0	10731	97.9	10836
		10	179.5	35.7	94.8	11893	97.2	12190	98.1	12309
		15	119.3	26.0	93.5	12827	95.9	13148	97.3	13340
		20	85.4	19.9	91.4	13431	93.7	13767	95.5	14035
		25	71.4	16.9	90.3	13462	92.5	13799	94.3	14068
		30	59.3	14.1	89.1	13356	91.3	13690	93.1	13957
		40	43.8	10.9	85.5	13399	87.7	13734	89.4	14002
		50	35.0	8.74	82.7	13011	84.8	13336	86.4	13596
	1170	60	29.2	7.00	80.8	12220	82.8	12526	84.4	12770
		70	25.0	5.74	78.1	11300	80.1	11583	81.6	11809
		5	228.3	43.4	95.3	11404	96.3	11518	97.2	11632
		7.5	158.1	35.2	94.7	13304	96.1	13504	97.1	13637
		10	120.0	30.4	93.9	14967	96.2	15341	97.2	15491
		15	79.8	22.1	92.3	16143	94.7	16547	96.0	16789
		20	57.1	17.0	89.8	16903	92.1	17326	93.9	17664
		25	47.8	14.1	88.5	16417	90.7	16827	92.5	17156
		30	39.7	11.9	87.2	16491	89.4	16903	91.1	17233
	100	40	29.3	9.18	83.0	16416	85.1	16826	86.8	17155
		50	23.4	7.43	79.9	15966	81.9	16365	83.4	16684
		60	19.5	6.03	77.7	15143	79.6	15522	81.2	15824
		70	16.7	4.96	74.7	13979	76.6	14328	78.1	14608
		5	19.5	9.25	88.4	26416	89.3	26680	90.2	26944
		7.5	13.5	6.97	87.4	28388	88.7	28814	89.6	29098
		10	10.3	6.15	85.4	32282	87.6	33089	88.4	33412
		15	6.8	4.16	82.7	31744	84.7	32538	86.0	33014
		20	4.9	3.35	77.6	33520	79.5	34358	81.1	35028
	SERIES GW80 RATINGS									
	1750	5	341.5	66.9	96.2	11866	97.1	11985	98.1	12103
		7.5	236.5	54.4	95.7	13867	97.2	14075	98.1	14214
		10	179.5	43.3	95.0	14447	97.4	14808	98.3	14953
		15	119.3	33.8	93.9	16766	96.2	17185	97.6	17437
		20	85.4	25.9	91.8	17575	94.1	18014	96.0	18366
		25	71.4	21.9	90.9	17578	93.1	18017	94.9	18369
		30	59.3	17.9	90.2	17166	92.4	17595	94.2	17938
		40	43.8	14.1	86.4	17507	88.5	17945	90.2	18295
		50	35.0	11.3	83.6	17028	85.7	17454	87.4	17794
	1170	60	29.2	9.05	81.8	15982	83.8	16382	85.5	16701
		70	25.0	7.37	79.4	14743	81.4	15112	82.9	15406
		5	228.3	56.6	95.6	14932	96.5	15081	97.5	15231
		7.5	158.1	46.1	95.0	17451	96.4	17713	97.4	17887
		10	120.0	36.8	94.2	18181	96.5	18636	97.5	18817
		15	79.8	28.8	92.8	21099	95.1	21626	96.5	21943
		20	57.1	22.2	90.4	22118	92.7	22671	94.5	23113
		25	47.8	18.8	89.2	22122	91.5	22675	93.3	23117
		30	39.7	15.0	88.4	21058	90.6	21584	92.4	22006
	100	40	29.3	12.2	84.1	22032	86.2	22583	87.8	23023
		50	23.4	9.84	80.9	21429	82.9	21965	84.5	22393
		60	19.5	7.63	78.8	19430	80.8	19916	82.4	20304
		70	16.7	6.24	76.2	17921	78.1	18369	79.6	18727

NOTE: ALL TORQUE VALUES LISTED IN INCH-POUNDS, ALL OVERHUNG LOAD VALUES LISTED IN POUNDS. THE POINT OF APPLICATION OF THE OVERHUNG LOAD IS CONSIDERED TO BE ONE SHAFT DIAMETER MEASURED OUTWARD FROM THE GEAR CASE HOUSING. AT SPEEDS ABOVE 1750 RPM, UNITS MAY BECOME THERMALLY LIMITED. FOR EXTENDED OPERATION, LIMIT INPUT HP TO 1750 RPM CATALOG RATING.

ADDITIONAL RATINGS FOR OTHER INPUT SPEEDS ARE AVAILABLE AT: WWW.HUBCITYINC.COM

CONTINUED ON NEXT PAGE



GW SERIES CATALOG RATINGS

SERIES GW80 & GW100

					CONVENTIONAL OIL		PAO SYNTHETIC OIL		PAG SYNTHETIC OIL	
	INPUT RPM	RATIO	OUTPUT RPM	MECH. INPUT HP	EFF. %	MECH. OUTPUT TORQUE	EFF. %	MECH. OUTPUT TORQUE	EFF. %	MECH. OUTPUT TORQUE
SERIES GW80 RATINGS (cont'd)	100	5	19.5	13.9	89.1	36447	90.0	36811	90.9	37176
		7.5	13.5	9.72	87.8	39793	89.1	40390	90.0	40788
		10	10.3	7.96	85.8	41958	88.0	43007	88.8	43427
		15	6.8	6.82	84.3	44195	86.4	45300	87.6	45963
		20	4.9	4.63	78.3	46792	80.2	47962	81.8	48898
		25	4.1	3.86	76.2	45421	78.1	46557	79.6	47465
		30	3.4	2.94	75.3	41088	77.2	42115	78.7	42937
		40	2.5	2.64	67.1	44687	68.7	45804	70.1	46698
		50	2.0	2.22	62.1	43469	63.6	44556	64.8	45425
		60	1.7	1.75	59.4	39244	60.9	40225	62.1	41010
70	1.4	1.48	55.6	36215	57.0	37120	58.1	37845		
SERIES GW100 RATINGS	1750	5	341.5	104.7	96.4	18619	97.4	18805	98.4	18991
		7.5	236.5	84.4	96.1	21413	97.5	21734	98.5	21948
		10	179.5	67.1	95.4	22466	97.7	23028	98.7	23252
		15	119.3	52.8	94.4	26308	96.7	26966	98.2	27360
		20	85.4	40.4	92.5	27597	94.8	28287	96.6	28839
		25	71.4	34.2	91.6	27618	93.9	28308	95.7	28861
		30	59.3	28.5	90.5	27433	92.8	28119	94.6	28667
		40	43.8	21.8	87.4	27471	89.6	28158	91.4	28707
		50	35.0	17.5	84.9	26703	87.0	27371	88.7	27905
		60	29.2	14.0	83.1	25107	85.2	25735	86.9	26237
	70	25.0	11.4	80.7	23235	82.7	23816	84.3	24281	
	1170	5	228.3	88.5	95.9	23431	96.9	23665	97.9	23900
		7.5	158.1	71.5	95.5	26947	96.9	27351	97.9	27621
		10	120.0	56.9	94.7	28273	97.0	28980	98.0	29263
		15	79.8	44.9	93.4	33107	95.8	33935	97.2	34431
		20	57.1	34.5	91.2	34730	93.5	35598	95.4	36293
		25	47.8	29.2	90.2	34756	92.4	35625	94.2	36320
		30	39.7	24.4	88.9	34523	91.2	35386	92.9	36077
		40	29.3	18.8	85.4	34571	87.5	35435	89.2	36127
		50	23.4	15.1	82.5	33605	84.6	34445	86.2	35117
		60	19.5	12.2	80.5	31597	82.5	32387	84.1	33019
	70	16.7	9.98	77.7	29240	79.7	29971	81.2	30556	
	100	5	19.5	22.1	89.5	63935	90.4	64574	91.3	65214
		7.5	13.5	16.5	88.6	67727	89.9	68743	90.8	69420
		10	10.3	13.7	86.5	72712	88.7	74530	89.6	75257
		15	6.8	9.95	84.1	77295	86.2	79227	87.4	80387
		20	4.9	8.01	79.3	82011	81.2	84061	82.8	85701
		25	4.1	6.70	77.2	79871	79.1	81868	80.7	83465
		30	3.4	5.49	75.1	76598	77.0	78513	78.5	80045
		40	2.5	4.54	68.4	78246	70.1	80202	71.5	81767
		50	2.0	3.79	63.6	75935	65.2	77833	66.4	79352
		60	1.7	3.01	60.7	69119	62.2	70847	63.4	72229
	70	1.4	2.59	56.5	64584	58.0	66199	59.1	67490	

NOTE: ALL TORQUE VALUES LISTED IN INCH-POUNDS, ALL OVERHUNG LOAD VALUES LISTED IN POUNDS. THE POINT OF APPLICATION OF THE OVERHUNG LOAD IS CONSIDERED TO BE ONE SHAFT DIAMETER MEASURED OUTWARD FROM THE GEAR CASE HOUSING. AT SPEEDS ABOVE 1750 RPM, UNITS MAY BECOME THERMALLY LIMITED. FOR EXTENDED OPERATION, LIMIT INPUT HP TO 1750 RPM CATALOG RATING.

THRUST AND OVERHUNG LOAD RATINGS (LBS.)	GW70	GW80	GW100
Thrust Load Ratings (Low Speed Shaft, All Ratios)	4009	4777	6808
Overhung Load Capacity* (High Speed Shaft, All Ratios)	450	450	50
Overhung Load Capacity* (Low Speed Shaft, All Ratios)	6209	7761	11028
Overhung Load Capacity** (Extended Brg Design Output Shaft, All Ratios)	3791	4850	8500

ADDITIONAL RATINGS FOR OTHER INPUT SPEEDS ARE AVAILABLE AT: WWW.HUBCITYINC.COM

*OHL AND THRUST VALUES SHOWN ARE INDEPENDENT FUNCTIONS AND CANNOT BE APPLIED SIMULTANEOUSLY. REFER APPLICATIONS WITH COMBINED OHL AND THRUST TO HUB CITY CUSTOMER SERVICE DEPARTMENT.

**THE POINT OF APPLICATION OF THE OVERHUNG LOAD IS CONSIDERED TO BE ONE SHAFT DIAMETER MEASURED OUTWARD FROM THE GEARCASE HOUSING.

**LOAD LOCATED AT END OF OUTPUT SHAFT.



MODELS

131, 181, 211, 241, 261, 321, 381, 451, 521, GW601, GW701, GW801, GW1001

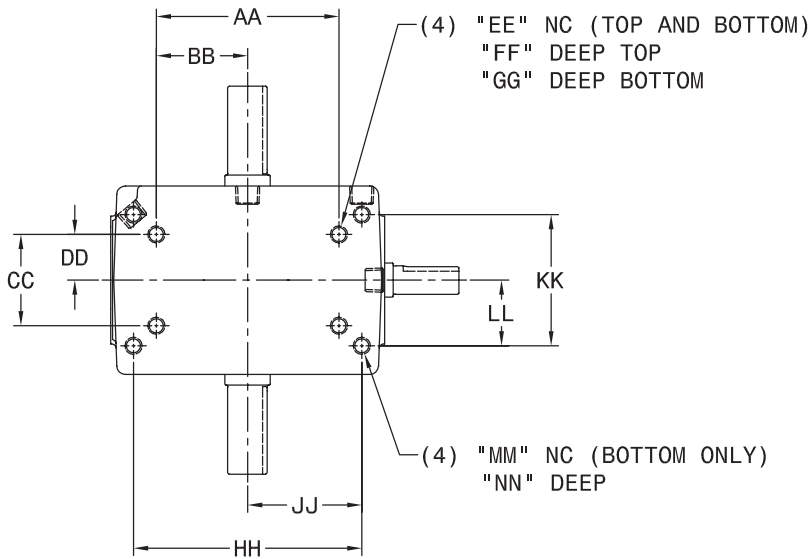
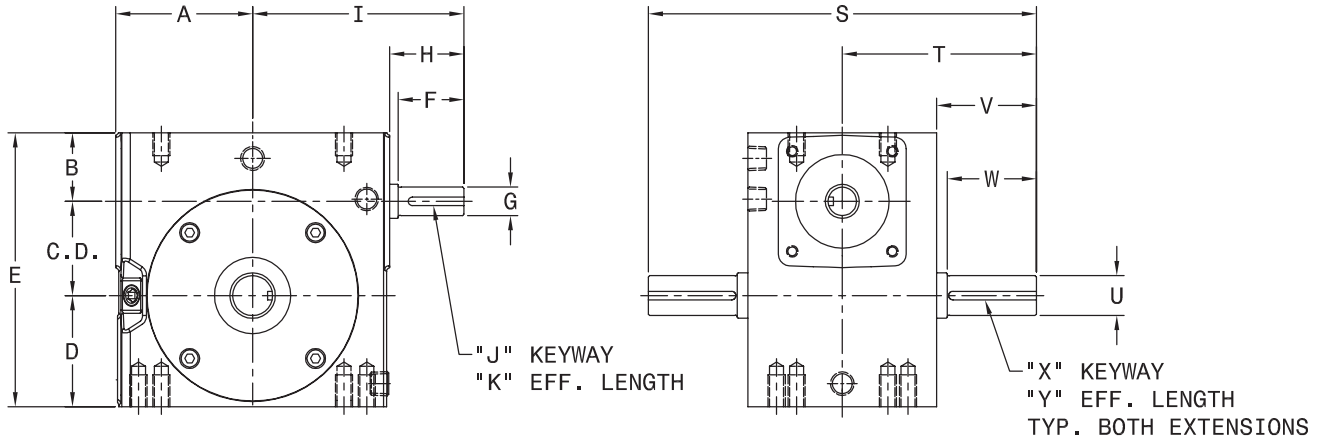

REFER TO FAN DETAILS ON NEXT PAGE FOR GW MODELS.

FOR LUBRICATION AND INSTALLATION INSTRUCTIONS - REFER TO SECTION R

STANDARD STYLES AVAILABLE

DIMENSIONS SHOWN ARE FOR REFERENCE ONLY.
DOWNLOAD AVAILABLE CAD MODELS AT:
WWW.HUBCITYINC.COM

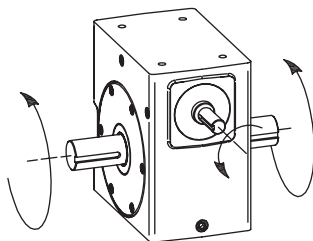

STYLE "A"

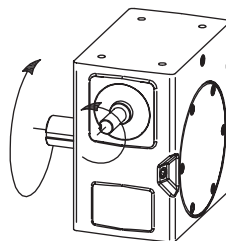

STYLE "B"

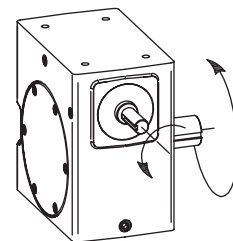

STYLE "C"

CONSULT FACTORY FOR VERTICAL SHAFT LUBRICATION RECOMMENDATIONS
INPUT SHAFT CAN BE ROTATED IN EITHER DIRECTION



MODELS

131, 181, 211, 241, 261, 321, 381, 451, 521, GW601, GW701, GW801, GW1001

MODEL	C.D.	A	B	D	E	F	G	H	I	J	K
131	1.334	2.28	1.186	1.562	4.082	1.35	.500/.499	1.54	3.82	1/8 X 1/16	1.16
181	1.751	2.65	1.374	1.875	5.000	1.35	.500/.499	1.54	4.19	1/8 X 1/16	1.16
211	2.064	3.00	1.500	2.437	6.000	1.44	.625/.624	1.63	4.63	3/16 X 3/32	1.13
241	2.376	3.38	2.062	2.500	6.938	1.43	.625/.624	1.63	5.00	3/16 X 3/32	1.21
261	2.626	3.66	1.874	2.938	7.438	1.73	.625/.624	1.97	5.63	3/16 X 3/32	1.49
321	3.251	4.40	2.124	3.250	8.625	2.23	.875/.874	2.48	6.88	3/16 X 3/32	1.91
381	3.751	4.90	2.374	3.937	10.062	2.20	1.000/.999	2.48	7.38	1/4 X 1/8	1.91
451	4.501	5.23	2.499	4.625	11.625	2.98	1.125/1.124	3.21	8.44	1/4 X 1/8	2.50
521	5.168	5.98	2.624	5.375	13.167	N/A	1.250/1.249	3.27	9.25	1/4 X 1/8	2.63
GW601	6.000	N/A	4.000	6.50	16.50	N/A	1.500	3.41	11.78	3/8 X 3/16	3.00
GW701	7.000	N/A	4.320	7.59	18.91	N/A	1.625	2.97	11.50	3/8 X 3/16	2.87
GW801	8.000	N/A	4.100	8.86	20.96	N/A	1.875	2.84	12.50	1/2 X 1/4	2.81
GW1001	10.000	N/A	5.110	10.36	25.47	N/A	2.250	3.76	15.50	1/2 X 1/4	3.69

MODEL	S	T	U	V	W	X	Y	AA	BB	CC	DD
131	6.50	3.25	.625/.624	1.69	N/A	3/16 X 3/32	1.38	2.250	1.125	1.625	0.812
181	7.00	3.50	.750/.749	1.78	1.54	3/16 X 3/32	1.41	3.125	1.562	1.625	0.812
211	8.50	4.25	.875/.874	2.19	1.95	3/16 X 3/32	1.83	4.000	2.000	2.000	1.000
241	9.00	4.50	1.125/1.124	2.31	2.06	1/4 X 1/8	1.74	5.000	2.500	2.875	1.438
261	9.00	4.50	1.250/1.249	2.25	N/A	1/4 X 1/8	1.85	4.875	2.437	2.688	1.344
321	10.88	5.44	1.375/1.374	2.84	N/A	5/16 X 5/32	2.31	6.250	3.125	2.750	1.375
381	13.38	6.69	1.500/1.499	3.88	N/A	3/8 X 3/16	3.16	6.875	3.438	3.000	1.500
451*	14.50	7.25	1.625/1.624	4.18	3.9	3/8 X 3/16	3.28	8.125	4.063	3.250	1.625
521**	15.62	7.81	1.750/1.749	4.47	4.17	3/8 X 3/16	3.50	9.500	4.750	3.750	1.875
GW601	20.00	10.00	2.500	4.65	N/A	5/8 X 5/16	4.00	12.75	6.380	6.380	3.190
GW701	23.52	11.76	2.750	5.65	N/A	5/8 X 5/16	4.00	12.50	6.250	5.500	2.750
GW801	25.00	12.25	3.000	5.98	5.26	3/4 X 3/8	4.50	14.25	7.125	6.500	3.250
GW1001	29.50	14.75	3.750	6.76	N/A	7/8 X 7/16	5.00	17.75	8.875	6.875	3.438

* ALSO AVAILABLE WITH 1.750/1.749 (M) DIAMETER OUTPUT SHAFT. CONSULT FACTORY.
 ** ALSO AVAILABLE WITH 2.000/1.999 (M) DIAMETER OUTPUT SHAFT. CONSULT FACTORY.

MODEL	EE	FF	GG	HH	JJ	KK	LL	MM	NN	Wt. Lbs.
131	1/4 UNC	0.50	0.50	3.250	1.625	2.000	1.000	5/16 NC	0.75	10
181	1/4 UNC	0.50	0.50	4.188	2.094	2.750	1.375	5/16 NC	0.75	15
211	3/8 UNC	0.50	0.70	5.000	2.500	2.875	1.438	3/8 NC	0.70	23
241	3/8 UNC	0.70	0.70	N/A	N/A	N/A	N/A	N/A	N/A	31
261	3/8 UNC	0.70	0.70	6.375	3.188	3.375	1.688	3/8 NC	0.70	37
321	1/2 UNC	0.75	0.90	7.500	3.750	4.000	2.000	7/16 NC	0.88	60
381	1/2 UNC	0.94	1.00	8.500	4.250	4.750	2.375	1/2 NC	1.00	85
451	5/8 UNC	0.88	1.13	N/A	N/A	N/A	N/A	N/A	N/A	102
521	5/8 UNC	1.00	1.25	N/A	N/A	N/A	N/A	N/A	N/A	128
GW601	5/8 UNC	1.00	1.00	N/A	N/A	N/A	N/A	N/A	N/A	321
GW701	1 UNC	1.56	1.56	N/A	N/A	N/A	N/A	N/A	N/A	399
GW801	1 UNC	1.66	1.66	N/A	N/A	N/A	N/A	N/A	N/A	582
GW1001	1-1/4 UNC	2.04	2.04	N/A	N/A	N/A	N/A	N/A	N/A	905

ADDITIONAL DETAIL FOR MODELS GW601 THROUGH GW1001

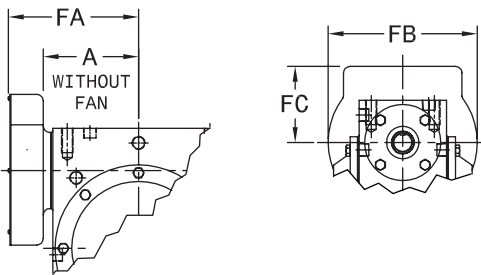

MODEL	A	FA	FB	FC
GW601	N/A	11.13	9.50	4.00
GW701	N/A	11.37	9.65	4.83
GW801	N/A	12.52	9.65	4.83
GW1001	N/A	14.69	11.28	5.62

ALL GW MODELS ARE FAN COOLED.

B
SINGLE REDUCTION



MODELS

182, 212, 242, 262, 322, 382, 452, 522, GW602, GW702, GW802, GW1002

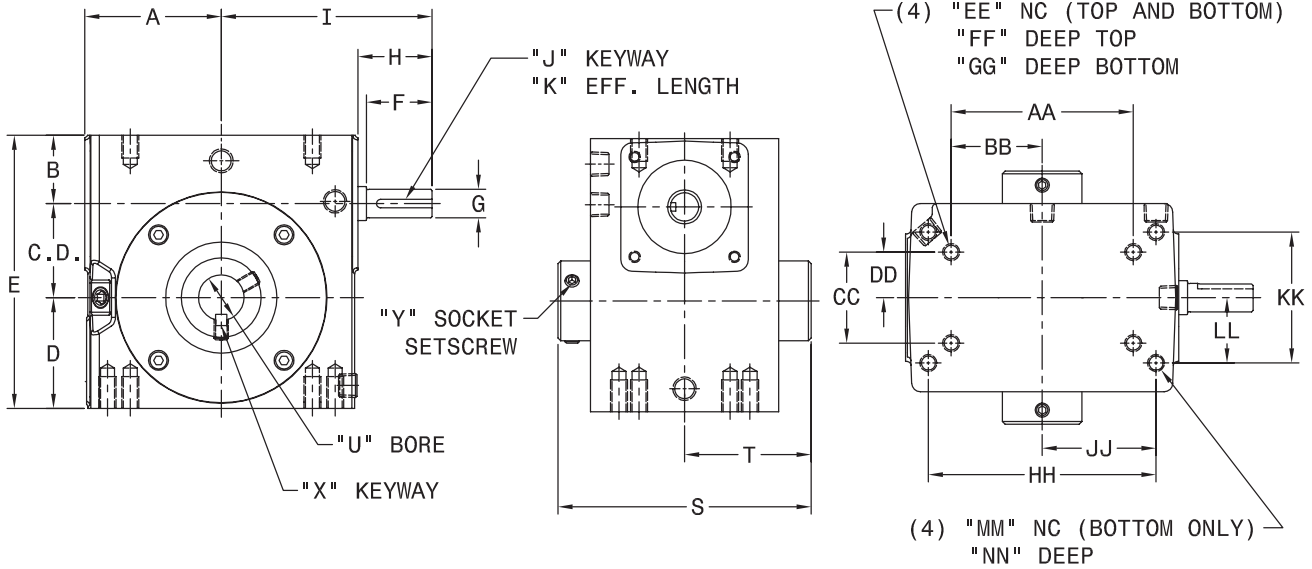

**QD BUSHING DETAIL FOR MODELS
452, 522**

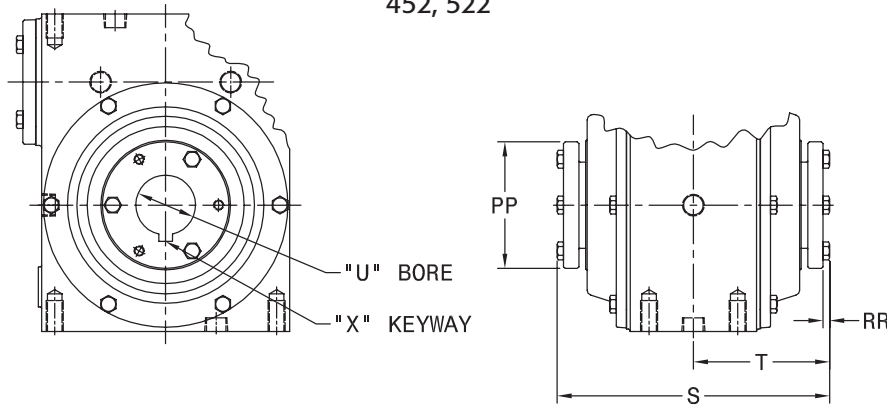

THESE UNITS CAN BE FURNISHED WITH SOLID OUTPUT SHAFT ON SPECIAL ORDERS.

SHAFT MOUNTED UNITS REQUIRE TORQUE ARMS. TORQUE ARM KITS ARE AVAILABLE. SEE PAGE B- 95

REFER TO FAN DETAIL ON NEXT PAGE FOR GW MODELS.

FOR LUBRICATION AND INSTALLATION INSTRUCTIONS - REFER TO SECTION R

STANDARD STYLES AVAILABLE

DIMENSIONS SHOWN ARE FOR REFERENCE ONLY. DOWNLOAD AVAILABLE CAD MODELS AT: WWW.HUBCITYINC.COM

STYLE SPECIFICATION REQUIRED ON POWERCUBE MODELS 182 THROUGH 382 ONLY.

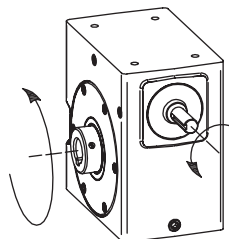

STYLE "A"

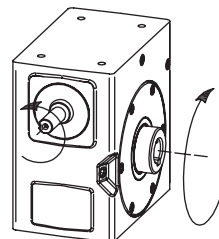

STYLE "B"

CONSULT FACTORY FOR VERTICAL SHAFT LUBRICATION RECOMMENDATIONS
INPUT SHAFT CAN BE ROTATED IN EITHER DIRECTION



MODELS

182, 212, 242, 262, 322, 382, 452, 522, GW602, GW702, GW802, GW1002

MODEL	C.D.	A	B	D	E	F	G	H	I	J	K	S	T
182	1.751	2.65	1.374	1.875	5.000	1.35	.500/.499	1.54	4.19	1/8 X 1/16	1.16	4.81	2.41
212	2.064	3.00	1.500	2.437	6.000	1.44	.625/.624	1.63	4.63	3/16 X 3/32	1.13	5.56	2.78
242	2.376	3.38	2.062	2.5	6.938	1.43	.625/.624	1.63	5.00	3/16 X 3/32	1.21	5.93	2.97
262	2.626	3.66	1.874	2.938	7.438	1.73	.625/.624	1.97	5.63	3/16 X 3/32	1.49	5.93	2.97
322	3.251	4.40	2.124	3.25	8.625	2.23	.875/.874	2.48	6.88	3/16 X 3/32	1.91	7.56	3.78
382	3.751	4.90	2.374	3.937	10.062	2.20	1.000/.999	2.48	7.38	1/4 X 1/8	1.91	7.56	3.78
452	4.501	5.23	2.499	4.625	11.625	2.98	1.125/1.124	3.21	8.44	1/4 X 1/8	2.5	10.00	5.00
522	5.168	5.98	2.624	5.375	13.167	N/A	1.250/1.249	3.27	9.25	1/4 X 1/8	2.63	11.13	5.56
GW602	6.000	N/A	4.000	6.50	16.50	N/A	1.500	3.41	11.78	3/8 X 3/16	3.00	11.50	5.75
GW702	7.000	N/A	4.320	7.59	18.91	N/A	1.625	2.97	11.50	3/8 X 3/16	2.87	13.50	6.75
GW802	8.000	N/A	4.100	8.86	20.96	N/A	1.875	2.84	12.50	1/2 X 1/4	2.81	14.50	7.25
GW1002	10.000	N/A	5.110	10.36	25.47	N/A	2.250	3.76	15.50	1/2 X 1/4	3.69	18.50	9.25

MODEL	AA	BB	CC	DD	EE	FF	GG	HH	JJ	KK	LL	MM	NN	WT. LBS.
182	3.125	1.562	1.625	0.812	1/4 NC	0.50	0.50	4.188	2.094	2.750	1.375	5/16 NC	0.75	15
212	4.000	2.000	2.000	1.000	3/8 NC	0.50	0.70	5.000	2.500	2.875	1.438	3/8 NC	0.70	24
242	5.000	2.500	2.875	1.438	3/8 NC	0.70	0.70	N/A	N/A	N/A	N/A	N/A	N/A	33
262	4.875	2.437	2.688	1.344	3/8 NC	0.70	0.70	6.375	3.188	3.375	1.688	3/8 NC	0.70	37
322	6.250	3.125	2.750	1.375	1/2 NC	0.75	0.90	7.500	3.750	4.000	2.000	7/16 NC	0.88	66
382	6.875	3.438	3.000	1.500	1/2 NC	0.94	1.00	8.500	4.250	4.750	2.375	1/2 NC	1.00	82
452	8.125	4.063	3.250	1.625	5/8 NC	0.88	1.13	N/A	N/A	N/A	N/A	N/A	N/A	107
522	9.500	4.750	3.750	1.875	5/8 NC	1.00	1.25	N/A	N/A	N/A	N/A	N/A	N/A	135
GW602	12.75	6.380	6.380	3.190	5/8 UNC	1.00	1.00	N/A	N/A	N/A	N/A	N/A	N/A	321
GW702	12.500	6.250	5.500	2.750	1 NC	1.56	1.56	N/A	N/A	N/A	N/A	N/A	N/A	399
GW802	14.250	7.125	6.500	3.250	1 NC	1.66	1.66	N/A	N/A	N/A	N/A	N/A	N/A	582
GW1002	17.750	8.875	6.875	3.438	1-1/4 NC	2.04	2.04	N/A	N/A	N/A	N/A	N/A	N/A	905

B
SINGLE REDUCTION

STOCK BORES

MODEL	U	X	KEY FURNISHED	Y
182	15/16	1/4 X 1/8	1/4 Sq.	10-24 NC X 1/4 LG
	1 (Max.)	1/4 X 1/8	1/4 Sq.	10-24 NC X 1/4 LG
212	15/16	1/4 X 1/8	1/4 Sq.	5/16 NC X 5/16 LG
	1	1/4 X 1/8	1/4 Sq.	5/16 NC X 5/16 LG
	1-3/16	1/4 X 1/8	1/4 Sq.	5/16 NC X 5/16 LG
242 & 262	1-1/4 (Max.)	1/4 X 1/8	1/4 Sq.	1/4 NC X 1/4 LG
	1	1/4 X 1/8	1/4 Sq.	5/16 NC X 5/16 LG
	1-3/16	1/4 X 1/8	1/4 Sq.	5/16 NC X 5/16 LG
	1-1/4	1/4 X 1/8	1/4 Sq.	5/16 NC X 5/16 LG
322 & 382	1-7/16 (Max.)	3/8 X 1/8	3/8 X 5/16	1/4 NC X 1/4 LG
	1-7/16	3/8 X 3/16	3/8 Sq.	3/8 NC X 5/8 LG
	1-15/16	1/2 X 1/4	1/2 Sq.	3/8 NC X 3/8 LG
	2	1/2 X 1/4	1/2 Sq.	3/8 NC X 3/8 LG
	2-3/16 (Max.)	1/2 X 1/8	1/2 Sq.	3/8 NC X 3/8 LG
GW602	2	1/2 x 1/4	NO	1/2 NC X 3/4 LG
	2-3/16	1/2 x 1/4	NO	1/2 NC X 3/4 LG
	2-1/4	1/2 x 1/4	NO	1/2 NC X 3/4 LG
	2-7/16	5/8 x 5/16	NO	1/2 NC X 3/4 LG
	2-1/2	5/8 x 5/16	NO	1/2 NC X 3/4 LG
	2-11/16	5/8 x 5/16	NO	1/2 NC X 3/4 LG
	2-15/16	3/4 x 3/8	NO	1/2 NC X 3/4 LG
	3	3/4 x 3/8	NO	1/2 NC X 3/4 LG
	3-3/16	3/4 x 3/8	NO	1/2 NC X 3/4 LG
	3-7/16	7/8 x 7/16	NO	1/2 NC X 3/4 LG
	2-7/16	5/8 X 5/16	NO	1/2 NC X 1/2 LG
GW702	2-1/2	5/8 X 5/16	NO	1/2 NC X 1/2 LG
	2-11/16	5/8 X 5/16	NO	1/2 NC X 1/2 LG
	2-15/16	3/4 X 3/8	NO	1/2 NC X 1/2 LG
	3	3/4 X 3/8	NO	1/2 NC X 1/2 LG
GW802	3-7/16	3/4 X 3/8	NO	1/2 NC X 1/2 LG
	3-15/16 (Max.)	1 X 1/4	1 X 3/4	1/2 NC X 1/2 LG
	3-7/16	7/8 X 7/16	NO	1/2 NC X 1/2 LG
	3-15/16	7/8 X 7/16	NO	1/2 NC X 1/2 LG
GW1002	4-3/16	1 X 1/2	NO	1/2 NC X 1/2 LG
	4-7/16 (Max.)	1 X 1/4	1 X 3/4	1/2 NC X 1/2 LG
	3-7/16	7/8 X 7/16	NO	5/8 NC X 5/8 LG
	3-15/16	7/8 X 7/16	NO	5/8 NC X 5/8 LG
	4-7/16	1 X 1/2	NO	5/8 NC X 5/8 LG
4-15/16	1-1/4 X 5/8	NO	5/8 NC X 5/8 LG	
5-7/16 (Max.)	1-1/4 X 5/16	1-1/4 X 15/16	5/8 NC X 5/8 LG	

QD BUSHING BORES

MODEL	U	X	Y	PP	RR	KEY	TYPE	KIT*
452	1-15/16	1/2 X 1/4	-	4-5/8	3/8	1/2 Sq.	SF	0229-02683
	2		-					0229-02684
	2-3/16	-	-			0229-02685		
	2-7/16	5/8 X 3/16	-			5/8 x 1/2		0229-02686
	2-15/16	3/4 X 1/32	-			3/4 x 13/32		0229-02687
522	2-3/16	1/2 X 1/4	-	6	7/16	1/2 Sq.	E	0229-02688
	2-7/16	5/8 X 3/16	-			5/8 Sq.		0229-02689
	2-15/16	-	-			-		0229-02690
	3	3/4 X 1/8	-			3/4 X 1/2		0229-02691
	3-3/16	-	-			-		0229-02692
	3-7/16	7/8 X 1/16	-			7/8 X 1/2		0229-02693

* ORDER BY QD BUSHING KIT NUMBER. BUSHING KITS ARE NOT INCLUDED IN REDUCER PRICE. KIT INCLUDES TWO BUSHINGS WITH KEYWAYS AND ONE KEY.

ADDITIONAL DETAIL FOR MODELS GW602 THROUGH GW1002

ALL GW MODELS ARE FAN COOLED.

MODEL	A	FA	FB	FC
GW602	N/A	11.13	9.50	4.00
GW702	N/A	11.37	9.65	4.83
GW802	N/A	12.52	9.65	4.83
GW1002	N/A	14.69	11.28	5.62

BORE TOLERANCE NOMINAL + .002 (MODELS 182 THRU 602)
BORE TOLERANCE NOMINAL + .0025 (MODELS GW602 THRU GW1002)



MODELS

183, 213, 243, 263, 323, 383

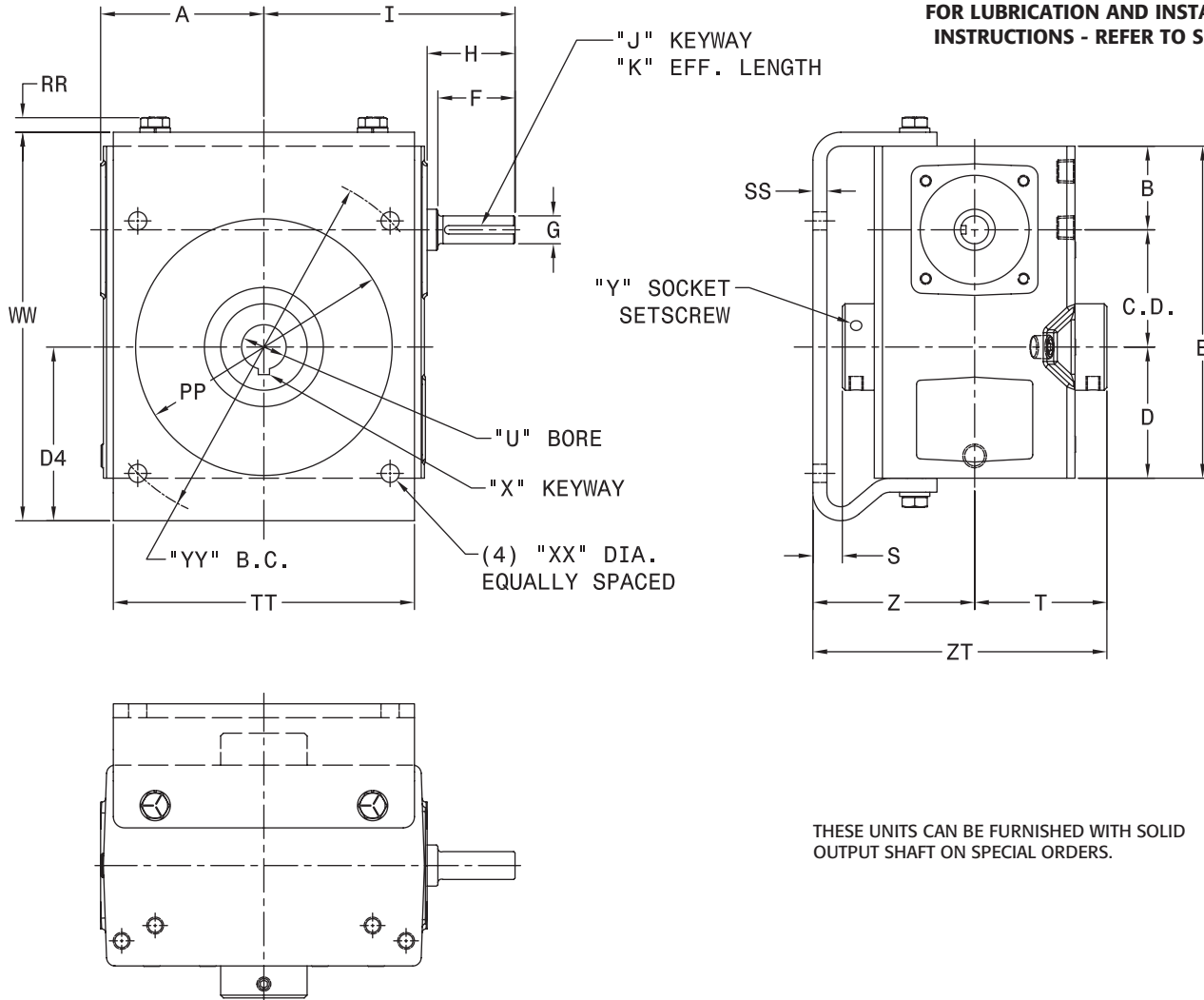

THESE UNITS CAN BE FURNISHED WITH SOLID OUTPUT SHAFT ON SPECIAL ORDERS.

STANDARD STYLES AVAILABLE

DIMENSIONS SHOWN ARE FOR REFERENCE ONLY.
DOWNLOAD AVAILABLE CAD MODELS AT:
WWW.HUBCITYINC.COM

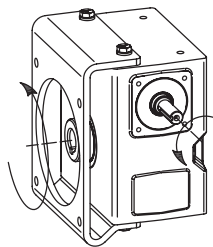

STYLE "L"

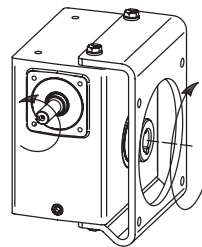

STYLE "R"

CONSULT FACTORY FOR VERTICAL SHAFT LUBRICATION RECOMMENDATIONS
INPUT SHAFT CAN BE ROTATED IN EITHER DIRECTION



MODELS

183, 213, 243, 263, 323, 383

MODEL	C.D.	A	B	D	E	F	G	H	I	J	K
183	1.751	2.65	1.374	1.875	5.000	1.35	.500/.499	1.54	4.19	1/8 X 1/16	1.16
213	2.064	3.00	1.500	2.437	6.000	1.44	.625/.624	1.63	4.63	3/16 X 3/32	1.13
243	2.376	3.38	2.062	2.500	6.938	1.43	.625/.624	1.63	5.00	3/16 X 3/32	1.21
263	2.626	3.66	1.874	2.938	7.438	1.73	.625/.624	1.97	5.63	3/16 X 3/32	1.49
323	3.251	4.40	2.124	3.250	8.625	2.23	.875/.874	2.48	6.88	3/16 X 3/32	1.91
383	3.751	4.90	2.374	3.937	10.062	2.20	1.000/.999	2.48	7.38	1/4 X 1/8	1.91

MODEL	D4	S	T	Z	PP	RR	SS	TT	WW	XX	YY	ZT	WT. LBS.
183	3.13	.91	2.41	3.31	4.25	.22	.25	4.88	6.50	11/32	5.875	5.71	18
213	3.75	.85	2.78	3.63	4.75	.33	.31	5.75	7.63	13/32	7.000	6.41	29
243	3.61	.75	2.97	3.72	5.00	.33	.25	6.00	8.30	13/32	7.500	6.69	38
263	3.89	.66	2.97	3.63	5.75	.33	.31	6.75	8.70	13/32	8.000	6.60	43
323	4.45	.22	3.78	4.00	6.88	.44	.31	7.50	10.14	13/32	9.000	7.78	74
383	5.09	.72	3.78	4.50	7.50	.44	.31	8.25	11.53	9/16	10.000	8.28	92

STOCK BORES

MODEL	U	X	KEY FURNISHED	Y
183	15/16	1/4 X 1/8	1/4 Sq.	10-24 NC X 1/4 LG
	1 (Max.)	1/4 X 1/8	1/4 Sq.	10-24 NC X 1/4 LG
213	15/16	1/4 X 1/8	1/4 Sq.	5/16 NC X 5/16 LG
	1	1/4 X 1/8	1/4 Sq.	5/16 NC X 5/16 LG
	1-3/16	1/4 X 1/8	1/4 Sq.	5/16 NC X 5/16 LG
	1-1/4 (Max.)	1/4 X 1/8	1/4 Sq.	1/4 NC X 1/4 LG
243 & 263	1	1/4 X 1/8	1/4 Sq.	5/16 NC X 5/16 LG
	1-3/16	1/4 X 1/8	1/4 Sq.	5/16 NC X 5/16 LG
	1-1/4	1/4 X 1/8	1/4 Sq.	5/16 NC X 5/16 LG
323 & 383	1-7/16 (Max.)	3/8 X 1/8	3/8 X 5/16	1/4 NC X 1/4 LG
	1-7/16	3/8 X 3/16	3/8 Sq.	3/8 NC X 5/8 LG
	1-15/16	1/2 X 1/4	1/2 Sq.	3/8 NC X 3/8 LG
	2	1/2 X 1/4	1/2 Sq.	3/8 NC X 3/8 LG
383	2-3/16 (Max.)	1/2 X 1/8	1/2 Sq.	3/8 NC X 3/8 LG

BORE TOLERANCE NOMINAL + .002

B

SINGLE REDUCTION



MODELS

453, 523

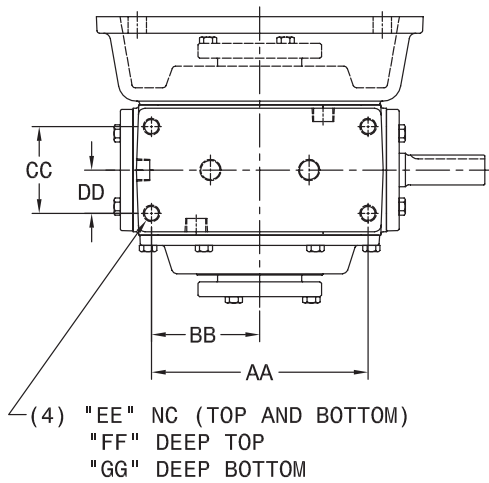
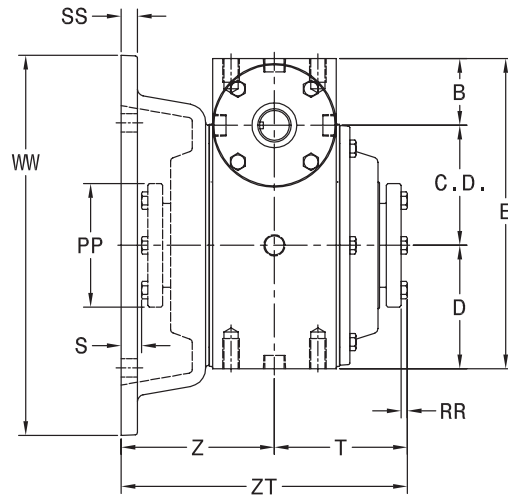
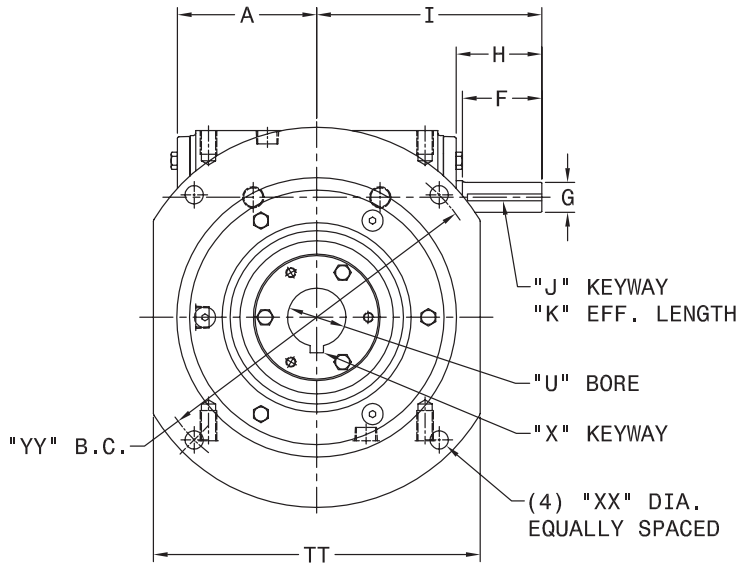

THESE UNITS CAN BE FURNISHED WITH SOLID OUTPUT SHAFT ON SPECIAL ORDER.

FOR LUBRICATION AND INSTALLATION INSTRUCTIONS - REFER TO SECTION R

STANDARD STYLES AVAILABLE

DIMENSIONS SHOWN ARE FOR REFERENCE ONLY.
 DOWNLOAD AVAILABLE CAD MODELS AT:
WWW.HUBCITYINC.COM

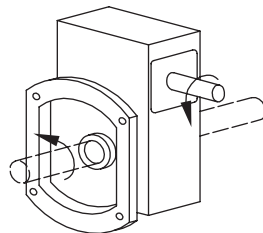

STYLE "L"

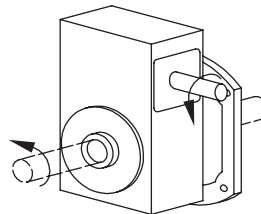

STYLE "R"

CONSULT FACTORY FOR VERTICAL SHAFT LUBRICATION RECOMMENDATIONS
 INPUT SHAFT CAN BE ROTATED IN EITHER DIRECTION



MODELS

453, 523

B

MODEL	C.D.	A	B	D	E	F	G	H	I	J	K	S	T
453	4.501	5.23	2.499	4.625	11.625	2.98	1.125/1.124	3.21	8.44	1/4 X 1/8	2.5	0.75	5.00
523	5.168	5.98	2.624	5.375	13.167	N/A	1.250/1.249	3.27	9.25	1/4 X 1/8	2.63	1.44	5.56

MODEL	Z	AA	BB	CC	DD	EE	FF	GG	SS	TT	WW	XX	YY	ZT	WT. LBS.
453	5.75	8.125	4.063	3.250	1.625	5/8 NC	0.88	1.13	0.63	12.25	14.25	11/16	13.00	10.75	115
523	7.00	9.500	4.750	3.750	1.875	5/8 NC	1.00	1.25	0.75	12.50	15.50	11/16	14.00	12.56	144

SINGLE REDUCTION

QD BUSHING BORES

MODEL	U	X	PP	RR	KEY	TYPE	KIT*
453	1-15/16	1/2 X 1/4	4-5/8	3/8	1/2 Sq.	SF	0229-02683
	2						0229-02684
	2-3/16	5/8 X 3/16			3/4 x 13/32		0229-02685
	2-7/16						0229-02686
	2-15/16						0229-02687
523	2-3/16	1/2 X 1/4	6	7/16	1/2 Sq.	E	0229-02688
	2-7/16	5/8 X 3/16			5/8 Sq.		0229-02689
	2-15/16	3/4 X 1/8			3/4 X 1/2		0229-02690
	3						0229-02691
	3-3/16						0229-02692
	3-7/16						7/8 X 1/16

* ORDER BY QD BUSHING KIT NUMBER. BUSHING KITS ARE NOT INCLUDED IN REDUCER PRICE. KIT INCLUDES TWO BUSHINGS WITH KEYWAYS AND ONE KEY.

BORE TOLERANCE NOMINAL + .002



MODELS

134, 184, 214, 244, 264, 324, 384, 454, 524, GW604

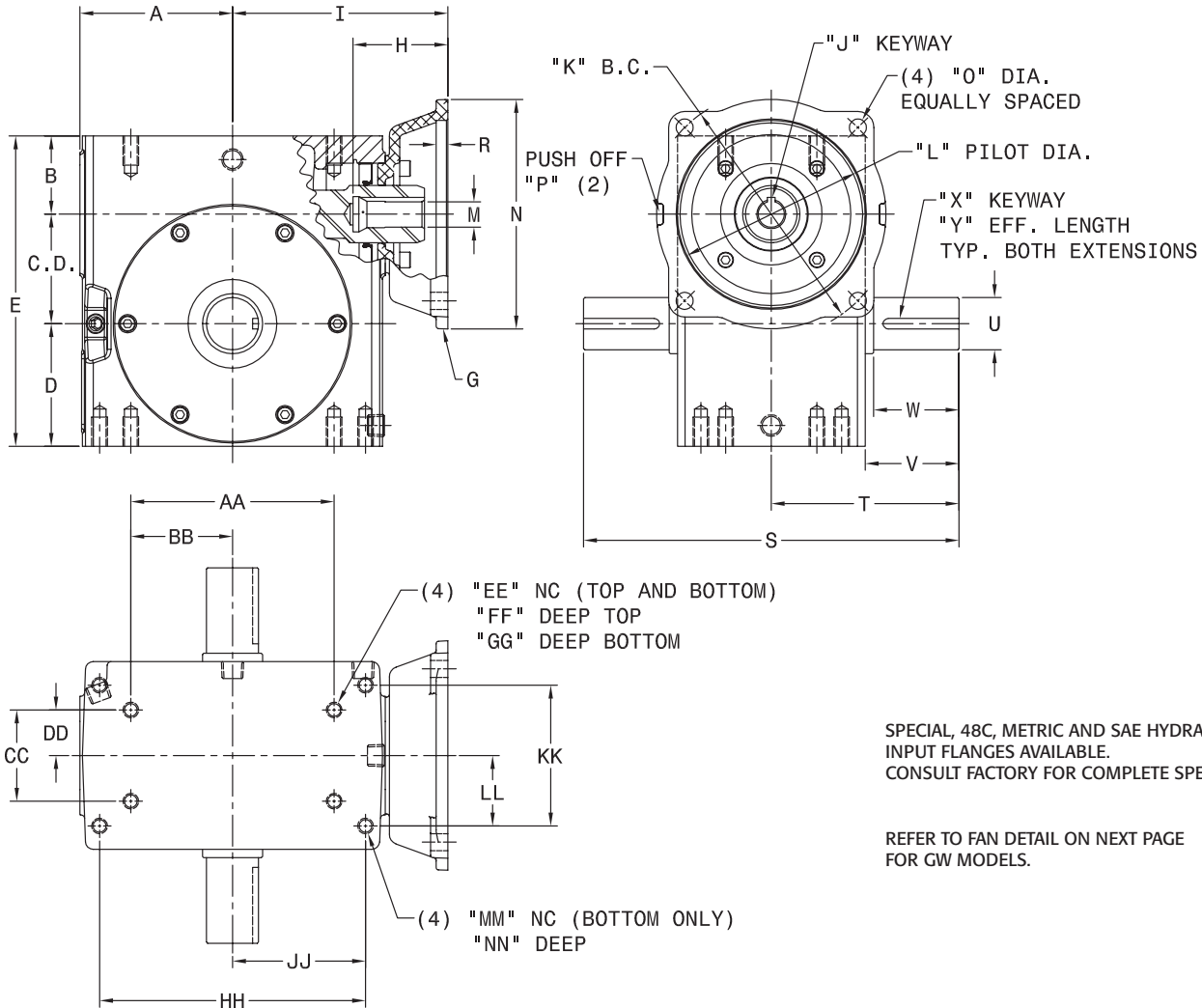

SPECIAL, 48C, METRIC AND SAE HYDRAULIC INPUT FLANGES AVAILABLE. CONSULT FACTORY FOR COMPLETE SPECIFICATIONS.

REFER TO FAN DETAIL ON NEXT PAGE FOR GW MODELS.

FOR LUBRICATION AND INSTALLATION INSTRUCTIONS - REFER TO SECTION R

STANDARD STYLES AVAILABLE

DIMENSIONS SHOWN ARE FOR REFERENCE ONLY. DOWNLOAD AVAILABLE CAD MODELS AT: WWW.HUBCITYINC.COM

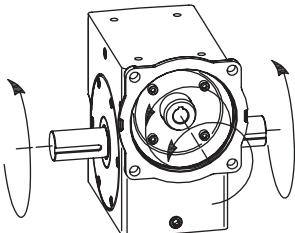

STYLE "A"

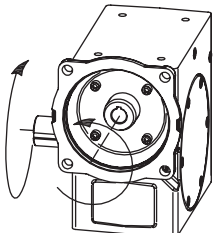

STYLE "B"

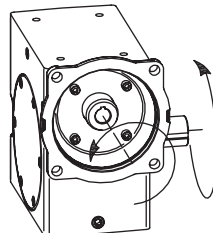

STYLE "C"

CONSULT FACTORY FOR VERTICAL SHAFT LUBRICATION RECOMMENDATIONS
 INPUT SHAFT CAN BE ROTATED IN EITHER DIRECTION



MODELS

134, 184, 214, 244, 264, 324, 384, 454, 524, GW604

B

SINGLE REDUCTION

MODEL	C.D.	A	B	D	E	G	H	I	J	K	L	M	N	O	P	R
134	1.334	2.28	1.186	1.562	4.082	56C	2.27	3.63	3/16 X 3/32	5.875	4.501/4.503	0.625	5.50	13/32	SLOTS	.19
184	1.751	2.65	1.374	1.875	5.000	56C	2.27	4.00	3/16 X 3/32	5.875	4.501/4.503	0.625	5.50	13/32	SLOTS	.19
214	2.064	3.00	1.500	2.437	6.000	56C	2.27	4.50	3/16 X 3/32	5.875	4.501/4.503	0.625	5.50	13/32	SLOTS	.19
						143TC	2.38					0.875				
244	2.376	3.38	2.062	2.500	6.938	56C	2.27	4.88	3/16 X 3/32	5.875	4.501/4.503	0.625	5.50	13/32	SLOTS	.19
						143TC	2.38					0.875				
						182TC	3.19					5.72				
264	2.626	3.66	1.874	2.938	7.438	56C	2.27	5.16	3/16 X 3/32	5.875	4.501/4.503	0.625	5.50	13/32	SLOTS	.19
						143TC	2.38					0.875				
						182TC	3.19					6.00				
324	3.251	4.40	2.124	3.250	8.625	56C	2.27	6.00	3/16 X 3/32	5.875	4.501/4.503	0.625	5.50	13/32	SLOTS	.19
						143TC	2.38					0.875				
						182TC	3.19					6.38				
384	3.751	4.90	2.374	3.937	10.062	56C	2.27	6.50	3/16 X 3/32	5.875	4.501/4.503	0.625	5.50	13/32	SLOTS	.19
						143TC	2.38					0.875				
						182TC	3.19					6.88				
454	4.501	5.67	2.499	4.625	11.625	56C	2.25	6.75	3/16 X 3/32	5.875	4.501/4.503	0.625	6.50	13/32	SLOTS	.44
						143TC	2.25					0.875				
						182TC	3.19					7.50				
524*	5.168	6.42	2.624	5.375	13.167	182TC	3.19	7.50	5/16 X 5/32	7.250	8.501/8.504	1.375	9.00	17/32	HOLES	.44
						213TC	3.50					1.375				
GW604	6.000	N/A	4.000	6.500	16.500	56C	4.42	10.45	3/16 x 3/32	5.875	4.501/4.503	0.625	6.50	13/32	HOLES	.38
						143TC	4.42	10.45	3/16 x 3/32	5.875	4.501/4.503	0.875	6.50	13/32	HOLES	.38
						182TC	3.30	9.33	1/4 x 1/8	7.250	8.501/8.504	1.125	9.00	17/32	HOLES	.50
						213TC	3.30	9.33	5/16 x 5/32	7.250	8.501/8.504	1.375	9.00	17/32	HOLES	.50
						254TC	3.91	9.94	3/8 x 3/16	7.250	8.501/8.504	1.625	9.00	17/32	HOLES	.50

* 56C & 143TC FLANGES AVAILABLE AS MODIFIED STANDARDS

MODEL	S	T	U	V	W	X	Y	AA	BB	CC	DD
134	6.50	3.25	.625/.624	1.69	N/A	3/16 X 3/32	1.38	2.250	1.125	1.625	.812
184	7.00	3.50	.750/.749	1.78	1.54	3/16 X 3/32	1.41	3.125	1.562	1.625	.812
214	8.50	4.25	.875/.874	2.19	1.95	3/16 X 3/32	1.83	4.000	2.000	2.000	1.000
244	9.00	4.50	1.125/1.124	2.31	2.06	1/4 X 1/8	1.74	5.000	2.500	2.875	1.438
264	9.00	4.50	1.250/1.249	2.25	N/A	1/4 X 1/8	1.85	4.875	2.437	2.688	1.344
324	10.88	5.44	1.375/1.374	2.84	N/A	5/16 X 5/32	2.31	6.250	3.125	2.750	1.375
384	13.38	6.69	1.500/1.499	3.88	N/A	3/8 X 3/16	3.16	6.875	3.438	3.000	1.500
454**	14.50	7.25	1.625/1.624	4.18	3.90	3/8 X 3/16	3.28	8.125	4.063	3.250	1.625
524***	15.62	7.81	1.750/1.749	4.47	4.17	3/8 X 3/16	3.50	9.500	4.750	3.750	1.875
GW604	20.00	10.00	2.500	4.65	N/A	5/8 X 5/16	4.00	12.750	6.380	6.380	3.190

** ALSO AVAILABLE WITH 1.750/1.749 (M) DIAMETER OUTPUT SHAFT. CONSULT FACTORY.

*** ALSO AVAILABLE WITH 2.000/1.999 (M) DIAMETER OUTPUT SHAFT. CONSULT FACTORY.

MODEL	EE	FF	GG	HH	JJ	KK	LL	MM	NN	WT. LBS.
134	1/4 UNC	.50	.50	3.250	1.625	2.000	1.000	5/16 NC	.75	11
184	1/4 UNC	.50	.50	4.188	2.094	2.750	1.375	5/16 NC	.75	16
214	3/8 UNC	.50	.75	5.000	2.500	2.875	1.438	3/8 NC	.70	25
244	3/8 UNC	.70	.70	N/A	N/A	N/A	N/A	N/A	N/A	33
264	3/8 UNC	.70	.70	6.375	3.188	3.375	1.688	3/8 NC	.70	38
324	1/2 UNC	.75	.90	7.500	3.750	4.000	2.000	7/16 NC	.88	64
384	1/2 UNC	.94	1.00	8.500	4.250	4.750	2.375	1/2 NC	1.00	90
454	5/8 UNC	.88	1.13	N/A	N/A	N/A	N/A	N/A	N/A	112
524	5/8 UNC	1.00	1.25	N/A	N/A	N/A	N/A	N/A	N/A	138
GW604	5/8 UNC	1.00	1.00	N/A	N/A	N/A	N/A	N/A	N/A	331

ADDITIONAL DETAIL FOR MODELS GW604

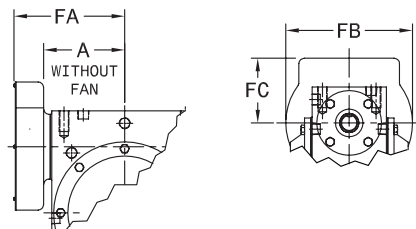

MODEL	A	FA	FB	FC
GW604	N/A	11.13	9.50	4.00



MODELS

185, 215, 245, 265, 325, 385, 455, 525, GW605

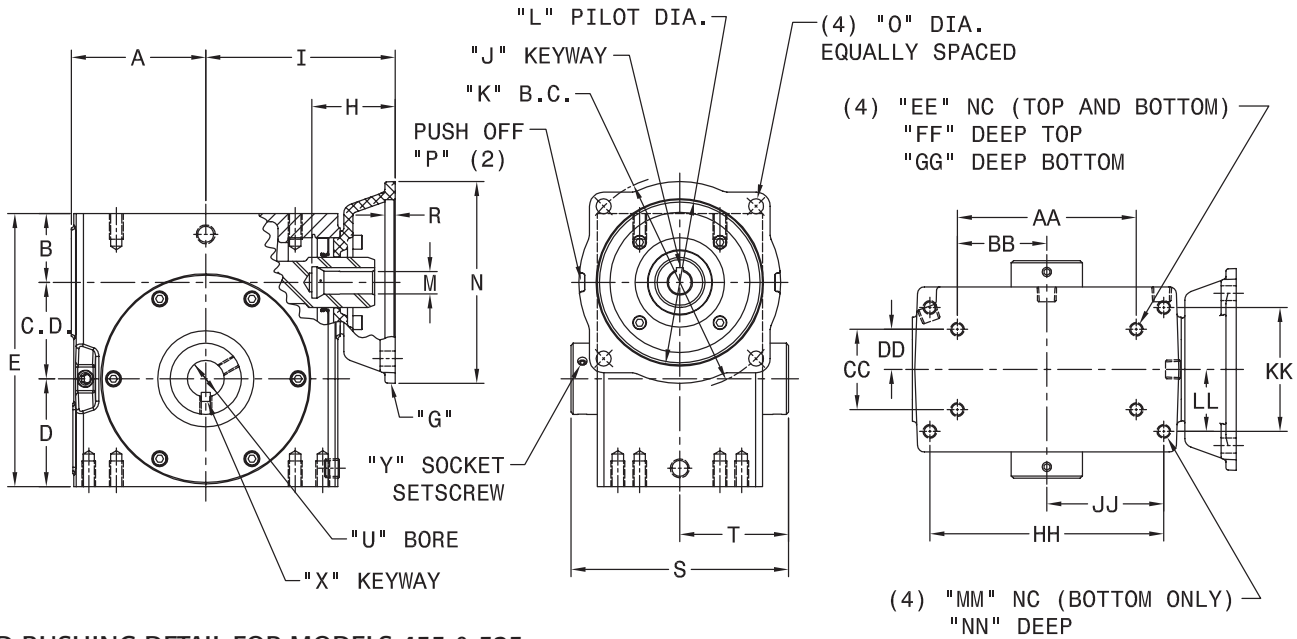

QD BUSHING DETAIL FOR MODELS 455 & 525

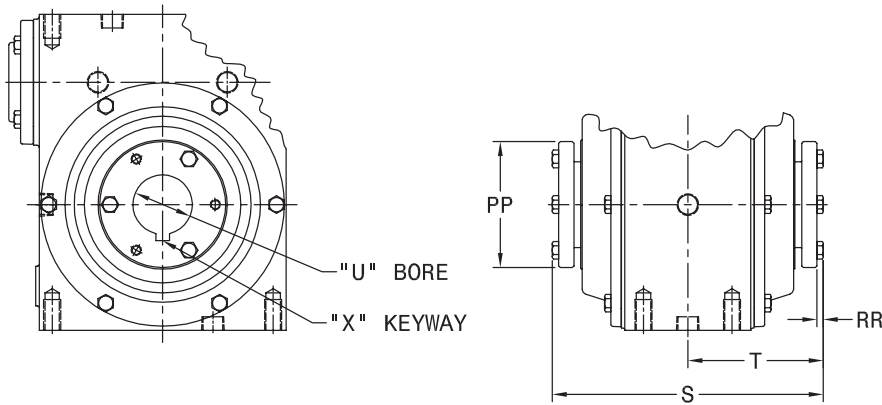

SPECIAL, 48C, METRIC AND SAE HYDRAULIC INPUT FLANGES AVAILABLE. CONSULT FACTORY FOR COMPLETE SPECIFICATIONS.

THESE UNITS CAN BE FURNISHED WITH SOLID OUTPUT SHAFT ON SPECIAL ORDERS.

SHAFT MOUNTED UNITS REQUIRE TORQUE ARMS. TORQUE ARM KITS ARE AVAILABLE. SEE PAGE B- 95

REFER TO FAN DETAIL ON NEXT PAGE FOR GW MODELS.

FOR LUBRICATION AND INSTALLATION INSTRUCTIONS - REFER TO SECTION R

DIMENSIONS SHOWN ARE FOR REFERENCE ONLY. DOWNLOAD AVAILABLE CAD MODELS AT: WWW.HUBCITYINC.COM

STANDARD STYLES AVAILABLE

STYLE SPECIFICATION REQUIRED ON POWERCUBE MODELS 185 THROUGH 385 ONLY.

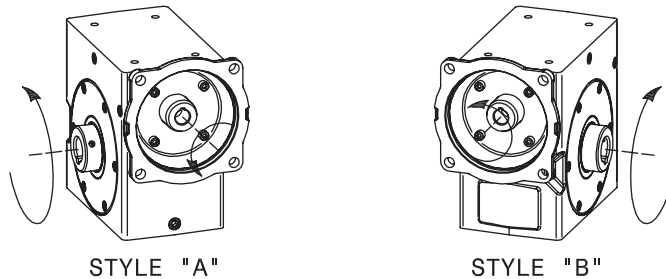

CONSULT FACTORY FOR VERTICAL SHAFT LUBRICATION RECOMMENDATIONS
 INPUT SHAFT CAN BE ROTATED IN EITHER DIRECTION



MODELS

185, 215, 245, 265, 325, 385, 455, 525, GW605

MODEL	C.D.	A	B	D	E	G	H	I	J	K	L	M	N	O	P	R
185	1.751	2.65	1.374	1.875	5.000	56C	2.27	4.00	3/16 X 3/32	5.875	4.501/4.503	.625	5.50	13/32	SLOTS	.19
215	2.064	3.00	1.500	2.437	6.000	56C	2.27	4.50	3/16 X 3/32	5.875	4.501/4.503	.625	5.50	13/32	SLOTS	.19
						143TC	2.38					.875				
245	2.376	3.38	2.062	2.500	6.938	56C	2.27	4.88	3/16 X 3/32	5.875	4.501/4.503	.625	5.50	13/32	SLOTS	.19
						143TC	2.38					.875				
						182TC	3.19	5.72	1/4 X 1/8	7.250	8.501/8.504	1.125	9.00	17/32	HOLES	.44
265	2.626	3.66	1.874	2.938	7.438	56C	2.27	5.16	3/16 X 3/32	5.875	4.501/4.503	.625	5.50	13/32	SLOTS	.19
						143TC	2.38					.875				
						182TC	3.19	6.00	1/4 X 1/8	7.250	8.501/8.504	1.125	9.00	17/32	HOLES	.44
325	3.251	4.40	2.124	3.250	8.625	56C	2.27	6.00	3/16 X 3/32	5.875	4.501/4.503	.625	5.50	13/32	SLOTS	.19
						143TC	2.38					.875				
						182TC	3.19	6.38	1/4 X 1/8	7.250	8.501/8.504	1.125	9.00	17/32	HOLES	.44
385	3.751	4.90	2.374	3.937	10.062	56C	2.27	6.50	3/16 X 3/32	5.875	4.501/4.503	.625	5.50	13/32	SLOTS	.19
						143TC	2.38					.875				
						182TC	3.19	6.88	1/4 X 1/8	7.250	8.501/8.504	1.125	9.00	17/32	HOLES	.44
455	4.501	5.67	2.499	4.625	11.625	56C	2.25	6.75	3/16 X 3/32	5.875	4.501/4.503	.625	6.50	13/32	SLOTS	.44
						143TC	2.25					.875				
						182TC	3.19	7.250	8.501/8.504	1.125	9.00	17/32	HOLES	.44		
						213TC	3.50			1.375						
525*	5.168	6.42	2.624	5.375	13.167	182TC	3.19	7.50	5/16 X 5/32	7.250	8.501/8.504	1.125	9.00	17/32	HOLES	.44
						213TC	3.50					1.375				
GW605	6.000	N/A	4.000	6.500	16.500	56C	4.42	10.45	3/16 x 3/32	5.875	4.501/4.503	.625	6.50	13/32	HOLES	.38
						143TC	3.30					9.33				
						182TC	3.30	9.33	5/16 x 5/32	7.250	8.501/8.504	1.125	9.00	17/32	HOLES	.50
						213TC	3.91					9.94				
						254TC	3.91	9.94	3/8 x 3/16			1.625				

* 56C & 143TC FLANGES AVAILABLE AS MODIFIED STANDARDS

MODEL	S	T	AA	BB	CC	DD	EE	FF	GG	HH	JJ	KK	LL	MM	NN	Wt. Lbs.
185	4.81	2.41	3.125	1.562	1.625	.812	1/4 NC	.50	.50	4.188	2.094	2.750	1.375	5/16 NC	.75	16
215	5.56	2.78	4.000	2.000	2.000	1.000	3/8 NC	.50	.70	5.000	2.500	2.875	1.438	3/8 NC	.70	25
245	5.93	2.97	5.000	2.500	2.875	1.438	3/8 NC	.70	.70	N/A	N/A	N/A	N/A	N/A	N/A	34
265	5.93	2.97	4.875	2.437	2.688	1.344	3/8 NC	.70	.70	6.375	3.188	3.375	1.688	3/8 NC	.70	38
325	7.56	3.78	6.250	3.125	2.750	1.375	1/2 NC	.75	.90	7.500	3.750	4.000	2.000	7/16 NC	.88	70
385	7.56	3.78	6.875	3.438	3.000	1.500	1/2 NC	.94	1.00	8.500	4.250	4.750	2.375	1/2 NC	1.00	86
455	10.00	5.00	8.125	4.063	3.250	1.625	5/8 NC	.88	1.13	N/A	N/A	N/A	N/A	N/A	N/A	117
525	11.13	5.56	9.500	4.750	3.750	1.875	5/8 NC	1.00	1.25	N/A	N/A	N/A	N/A	N/A	N/A	145
GW605	11.50	5.75	12.750	6.380	6.380	3.190	5/8 NC	1.00	1.00	N/A	N/A	N/A	N/A	N/A	N/A	331

STOCK BORES

MODEL	U	X	KEY FURNISHED	Y
185	15/16	1/4 X 1/8	1/4 Sq.	10-24 NC X 1/4 LG
	1 (Max.)	1/4 X 1/8	1/4 Sq.	10-24 NC X 1/4 LG
	15/16	1/4 X 1/8	1/4 Sq.	5/16 NC X 5/16 LG
215	1	1/4 X 1/8	1/4 Sq.	5/16 NC X 5/16 LG
	1-3/16	1/4 X 1/8	1/4 Sq.	5/16 NC X 5/16 LG
	1-1/4 (Max.)	1/4 X 1/8	1/4 Sq.	1/4 NC X 1/4 LG
245 & 265	1	1/4 X 1/8	1/4 Sq.	5/16 NC X 5/16 LG
	1-3/16	1/4 X 1/8	1/4 Sq.	5/16 NC X 5/16 LG
	1-1/4	1/4 X 1/8	1/4 Sq.	5/16 NC X 5/16 LG
	1-7/16 (Max.)	3/8 X 1/8	3/8 X 5/16	1/4 NC X 1/4 LG
325 & 385	1-7/16	3/8 X 3/16	3/8 Sq.	3/8 NC X 5/8 LG.
	1-15/16	1/2 X 1/4	1/2 Sq.	3/8 NC X 3/8 LG.
	2	1/2 X 1/4	1/2 Sq.	3/8 NC X 3/8 LG.
	2-3/16 (Max.)	1/2 X 1/8	1/2 Sq.	3/8 NC X 3/8 LG.
GW605	2	1/2 x 1/4	NO	1/2 NC X 3/4 LG
	2-3/16	1/2 x 1/4	NO	1/2 NC X 3/4 LG
	2-1/4	1/2 x 1/4	NO	1/2 NC X 3/4 LG
	2-7/16	5/8 x 5/16	NO	1/2 NC X 3/4 LG
	2-1/2	5/8 x 5/16	NO	1/2 NC X 3/4 LG
	2-11/16	5/8 x 5/16	NO	1/2 NC X 3/4 LG
	2-15/16	3/4 x 3/8	NO	1/2 NC X 3/4 LG
	3	3/4 x 3/8	NO	1/2 NC X 3/4 LG
	3-3/16	3/4 x 3/8	NO	1/2 NC X 3/4 LG
	3-7/16	7/8 x 7/16	NO	1/2 NC X 3/4 LG

QD BUSHING BORES

MODEL	U	X	Y	PP	RR	Key	TYPE	KIT**
455	1-15/16	1/2 X 1/4	-	4-5/8	3/8	1/2 Sq.	SF	0229-02683
	2		-					0229-02684
	2-3/16	-	0229-02685					
	2-7/16	5/8 X 3/16	-					0229-02686
525	2-15/16	3/4 X 1/32	-	6	7/16	3/4 x 13/32	E	0229-02687
	2-3/16	1/2 X 1/4	-			1/2 Sq.		0229-02688
	2-7/16	5/8 X 3/16	-			5/8 Sq.		0229-02689
	2-15/16	-	-			-		0229-02690
	3	3/4 X 1/8	-			-		0229-02691
	3-3/16	-	-			-		0229-02692
	3-7/16	7/8 X 1/16	-			-		0229-02693

**ORDER BY QD BUSHING KIT NUMBER. BUSHING KITS ARE NOT INCLUDED IN REDUCER PRICE.

KIT INCLUDES TWO BUSHINGS WITH KEYWAYS AND ONE KEY

ADDITIONAL DETAIL FOR MODELS GW605

MODEL	A	FA	FB	FC
GW605	N/A	11.13	9.50	4.00

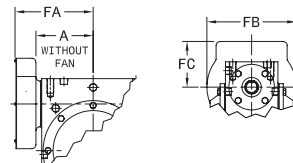

BORE TOLERANCE NOMINAL +.002



MODELS

186, 216, 246, 266, 326, 386

FOR LUBRICATION AND INSTALLATION INSTRUCTIONS - REFER TO SECTION R

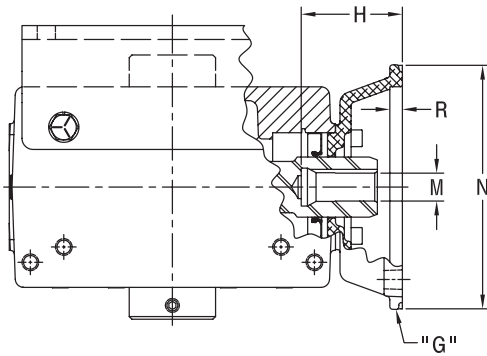
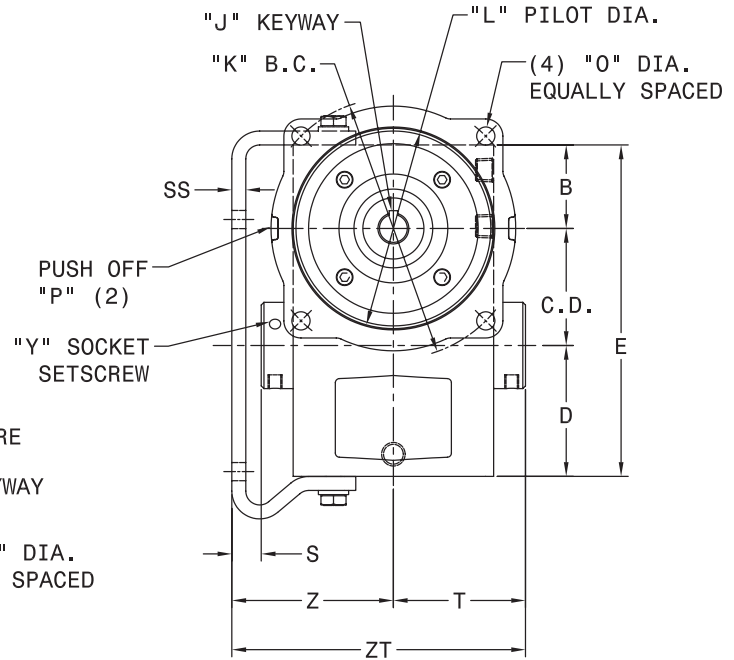
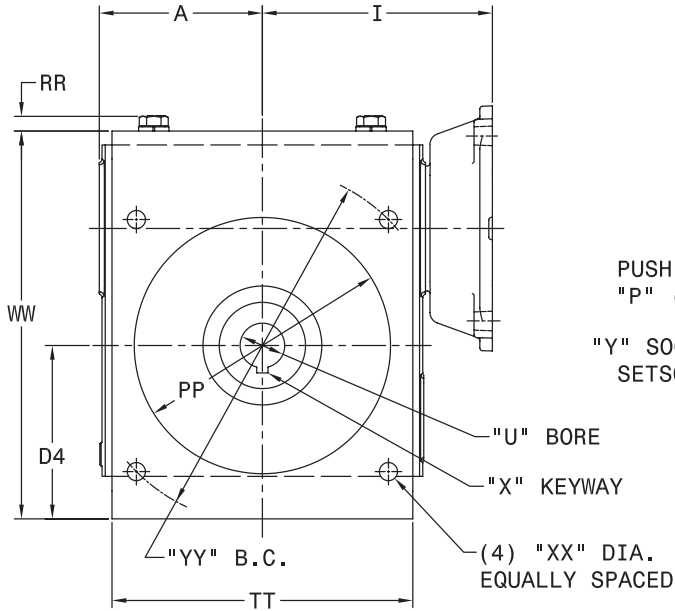

SPECIAL, 48C, METRIC AND SAE HYDRAULIC INPUT FLANGES AVAILABLE. CONSULT FACTORY FOR COMPLETE SPECIFICATIONS.

THESE UNITS CAN BE FURNISHED WITH SOLID OUTPUT SHAFT ON SPECIAL ORDERS.

STANDARD STYLES AVAILABLE

DIMENSIONS SHOWN ARE FOR REFERENCE ONLY. DOWNLOAD AVAILABLE CAD MODELS AT: WWW.HUBCITYINC.COM

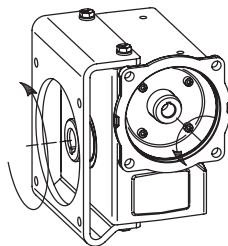

STYLE "L"

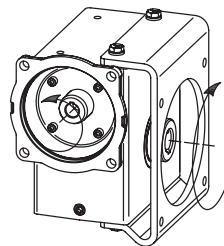

STYLE "R"

CONSULT FACTORY FOR VERTICAL SHAFT LUBRICATION RECOMMENDATIONS
INPUT SHAFT CAN BE ROTATED IN EITHER DIRECTION



MODELS

186, 216, 246, 266, 326, 386

B

SINGLE REDUCTION

MODEL	C.D.	A	B	D	E	G	H	I	J	K	L	M	N	O	P	R
186	1.751	2.65	1.374	1.875	5.000	56C	2.27	4.00	3/16 X 3/32	5.875	4.501/4.503	.625	5.50	13/32	SLOTS	.19
216	2.064	3.00	1.500	2.437	6.000	56C	2.27	4.50	3/16 X 3/32	5.875	4.501/4.503	.625	5.50	13/32	SLOTS	.19
						143TC	2.38					.875				
246	2.376	3.38	2.062	2.500	6.938	56C	2.27	4.88	3/16 X 3/32	5.875	4.501/4.503	.625	5.50	13/32	SLOTS	.19
						143TC	2.38					.875				
						182TC	3.19					5.72				
266	2.626	3.66	1.874	2.938	7.438	56C	2.27	5.16	3/16 X 3/32	5.875	4.501/4.503	.625	5.50	13/32	SLOTS	.19
						143TC	2.38					.875				
						182TC	3.19					6.00				
326	3.251	4.40	2.124	3.250	8.625	56C	2.27	6.00	3/16 X 3/32	5.875	4.501/4.503	.625	5.50	13/32	SLOTS	.19
						143TC	2.38					.875				
						182TC	3.19					6.38				
386	3.751	4.90	2.374	3.937	10.062	56C	2.27	6.50	3/16 X 3/32	5.875	4.501/4.503	.625	5.50	13/32	SLOTS	.19
						143TC	2.38					.875				
						182TC	3.19					6.88				

MODEL	D4	S	T	Z	PP	RR	SS	TT	WW	XX	YY	ZT	WT. LBS.
186	3.13	.91	2.41	3.31	4.25	.22	.25	4.88	6.50	11/32	5.875	5.71	19
216	3.75	.85	2.78	3.63	4.75	.33	.31	5.75	7.63	13/32	7.000	6.41	30
246	3.61	.75	2.97	3.72	5.00	.33	.25	6.00	8.30	13/32	7.500	6.69	39
266 (56C-143TC)	3.89	.66	2.97	3.63	5.75	.33	.31	6.75	8.70	13/32	8.000	6.60	44
266 (182TC)	4.07	1.66	2.97	4.63	5.75	.33	.31	6.75	8.88	13/32	8.000	7.60	53
326	4.45	.22	3.78	4.00	6.88	.44	.31	7.50	10.14	13/32	9.000	7.78	78
386	5.09	.72	3.78	4.50	7.50	.44	.31	8.25	11.53	9/16	10.000	8.28	96

STOCK BORES

MODEL	U	X	KEY FURNISHED	Y
186	15/16	1/4 X 1/8	1/4 Sq.	10-24 NC X 1/4 LG
	1 (Max.)	1/4 X 1/8	1/4 Sq.	10-24 NC X 1/4 LG
216	15/16	1/4 X 1/8	1/4 Sq.	5/16 NC X 5/16 LG
	1	1/4 X 1/8	1/4 Sq.	5/16 NC X 5/16 LG
	1-3/16	1/4 X 1/8	1/4 Sq.	5/16 NC X 5/16 LG
	1-1/4 (Max.)	1/4 X 1/8	1/4 Sq.	1/4 NC X 1/4 LG
246 & 266	1	1/4 X 1/8	1/4 Sq.	5/16 NC X 5/16 LG
	1-3/16	1/4 X 1/8	1/4 Sq.	5/16 NC X 5/16 LG
	1-1/4	1/4 X 1/8	1/4 Sq.	5/16 NC X 5/16 LG
	1-7/16 (Max.)	3/8 X 1/8	3/8 X 5/16	1/4 NC X 1/4 LG
326 & 386	1-7/16	3/8 X 3/16	3/8 Sq.	3/8 NC X 5/8 LG
	1-15/16	1/2 X 1/4	1/2 Sq.	3/8 NC X 3/8 LG
	2	1/2 X 1/4	1/2 Sq.	3/8 NC X 3/8 LG
	2-3/16 (Max.)	1/2 X 1/8	1/2 Sq.	3/8 NC X 3/8 LG

BORE TOLERANCE NOMINAL +.002



MODELS

456, 526

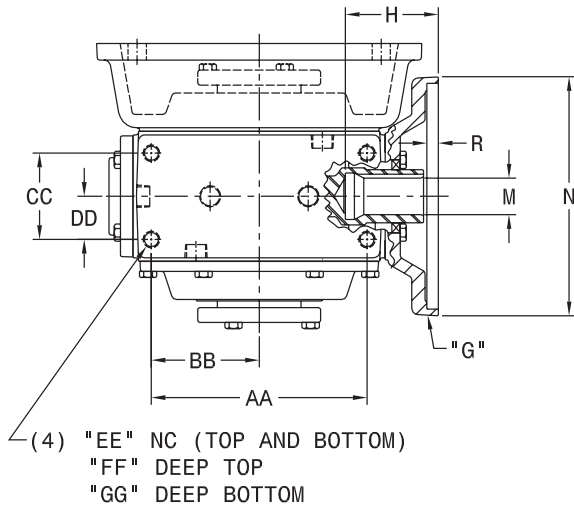
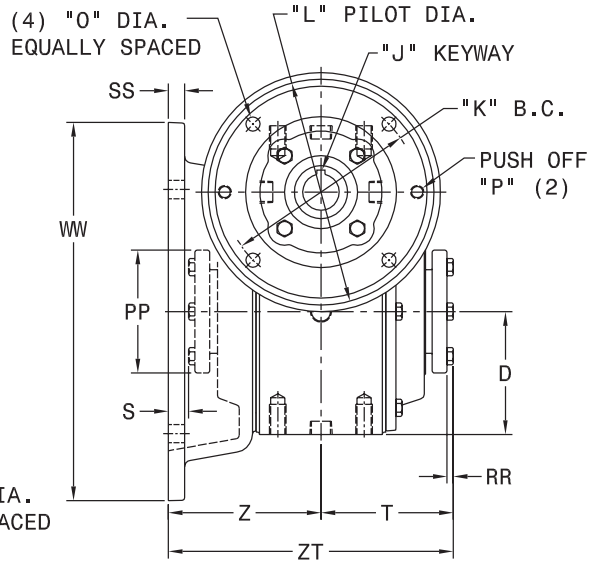
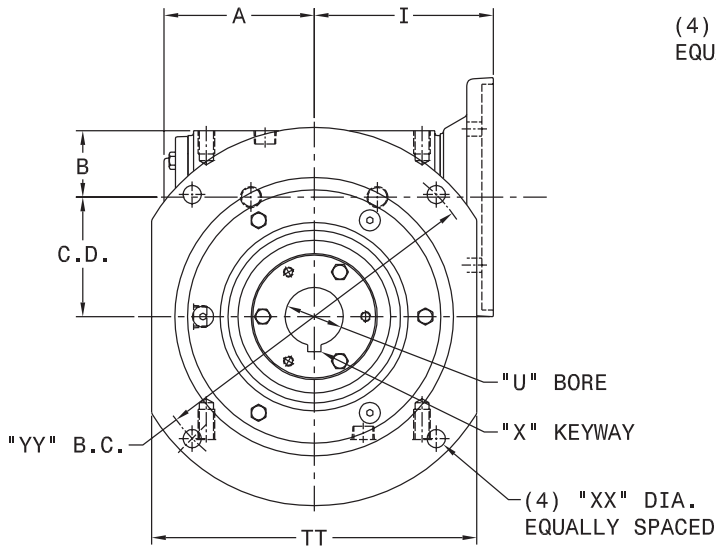

SPECIAL, 48C, METRIC AND SAE HYDRAULIC INPUT FLANGES AVAILABLE. CONSULT FACTORY FOR COMPLETE SPECIFICATIONS.

THESE UNITS CAN BE FURNISHED WITH SOLID OUTPUT SHAFT ON SPECIAL ORDERS.

FOR LUBRICATION AND INSTALLATION INSTRUCTIONS - REFER TO SECTION R

STANDARD STYLES AVAILABLE

DIMENSIONS SHOWN ARE FOR REFERENCE ONLY. DOWNLOAD AVAILABLE CAD MODELS AT: WWW.HUBCITYINC.COM

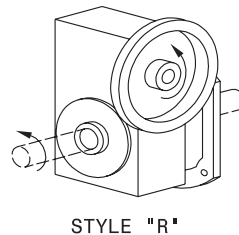
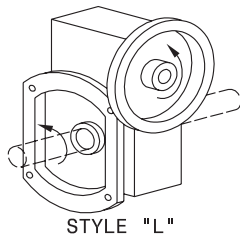

CONSULT FACTORY FOR VERTICAL SHAFT LUBRICATION RECOMMENDATIONS
INPUT SHAFT CAN BE ROTATED IN EITHER DIRECTION



MODELS

456, 526

B

SINGLE REDUCTION

MODEL	C.D.	A	B	D	G	H	I	J	K	L	M	N	O	P	R
456	4.501	5.67	2.499	4.625	56C	2.25	6.75	3/16 X 3/32	5.875	4.501/4.503	.625	6.50	13/32	SLOTS	.44
					143TC	2.25					.875				
					182TC	3.19		1/4 X 1/8	7.250	8.501/8.504	1.125				
					213TC	3.50					5/16 X 5/32				
526*	5.168	6.42	2.624	5.375	182TC	3.19	7.50	1/4 X 1/8	7.250	8.501/8.504	1.125	9.00	17/32	HOLES	.44
					213TC	3.50					5/16 X 5/32				

MODEL	S	T	Z	AA	BB	CC	DD	EE	FF	GG	SS	TT	WW	XX	YY	ZT	WT. LBS.
456	.75	5.00	5.75	8.125	4.063	3.250	1.625	5/8 NC	.88	1.13	.63	12.25	14.25	11/16	13.00	10.75	125
526	1.44	5.56	7.00	9.500	4.750	3.750	1.875	5/8 NC	1.00	1.25	.75	12.50	15.50	11/16	14.00	12.56	154

* 56C & 143TC FLANGES AVAILABLE AS MODIFIED STANDARDS

QD BUSHING BORES

MODEL	U	X	PP	RR	Key	TYPE	KIT**	
456	1-15/16	1/2 X 1/4	4-5/8	3/8	1/2 Sq.	SF	0229-02683	
	2						0229-02684	
	2-3/16	0229-02685						
	2-7/16	5/8 X 3/16					5/8 x 1/2	0229-02686
	2-15/16	3/4 X 1/32					3/4 x 13/32	0229-02687
526	2-3/16	1/2 X 1/4	6	7/16	1/2 Sq.	E	0229-02688	
	2-7/16	5/8 X 3/16			5/8 Sq.		0229-02689	
	2-15/16	3/4 X 1/8			3/4 X 1/2		0229-02690	
	3						0229-02691	
	3-3/16						0229-02692	
3-7/16	7/8 X 1/16	7/8 X 1/2	0229-02693					

**ORDER BY QD BUSHING KIT NUMBER. BUSHING KITS ARE NOT INCLUDED IN REDUCER PRICE.

KIT INCLUDES TWO BUSHINGS WITH KEYWAYS AND ONE KEY



MODELS

327, 387, 457, 527, GW607, GW707, GW807, GW1007

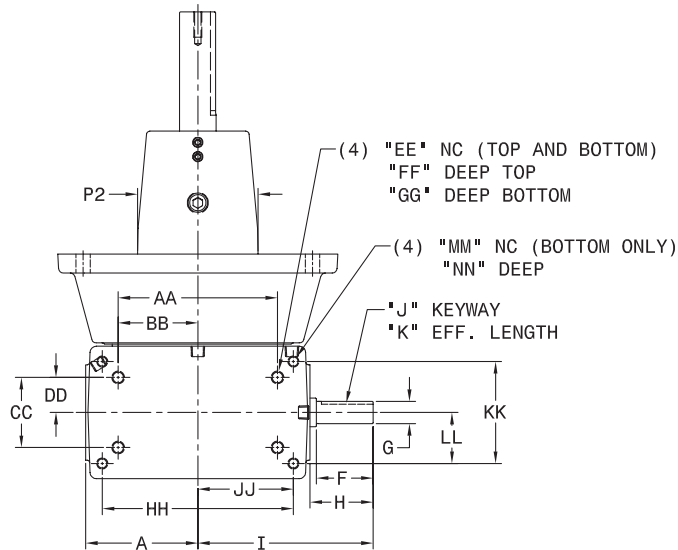
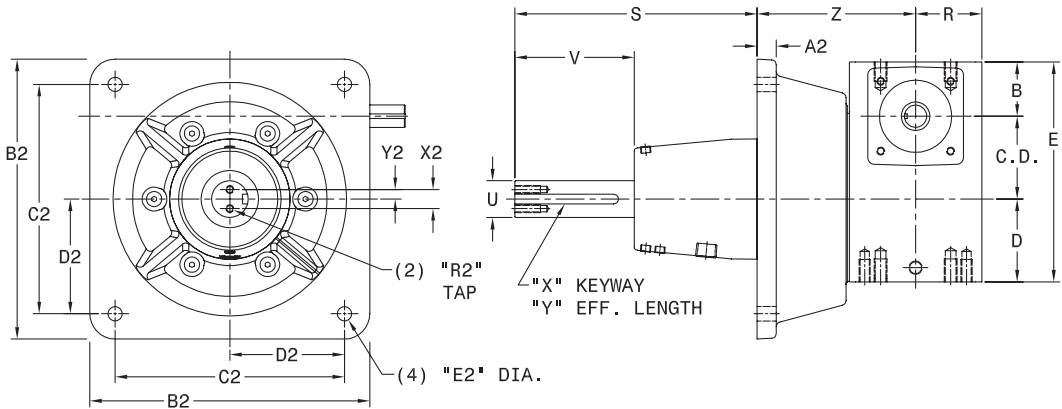

REFER TO FAN DETAIL ON NEXT PAGE FOR GW MODELS.

FOR LUBRICATION AND INSTALLATION INSTRUCTIONS - REFER TO SECTION R

STANDARD STYLES AVAILABLE

DIMENSIONS SHOWN ARE FOR REFERENCE ONLY.
 DOWNLOAD AVAILABLE CAD MODELS AT:
WWW.HUBCITYINC.COM

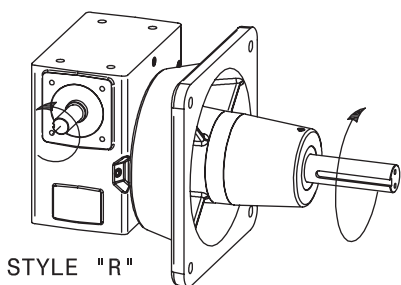
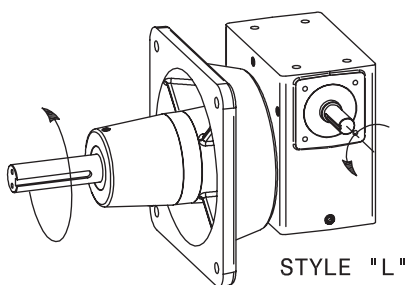

CONSULT FACTORY FOR VERTICAL SHAFT LUBRICATION RECOMMENDATIONS
 INPUT SHAFT CAN BE ROTATED IN EITHER DIRECTION



MODELS

327, 387, 457, 527, GW607, GW707, GW807, GW1007

B

SINGLE REDUCTION

MODEL	C.D.	A	B	D	E	F	G	H	I	J	K	R
327	3.251	4.40	2.124	3.250	8.625	2.23	.875/.874	2.48	6.88	3/16 X 3/32	1.91	2.60
387	3.751	4.90	2.374	3.937	10.062	N/A	1.000/.999	2.48	7.38	1/4 X 1/8	1.91	2.81
457	4.501	5.23	2.499	4.625	11.625	2.98	1.125/1.124	3.21	8.44	1/4 X 1/8	2.50	3.06
527	5.168	5.98	2.624	5.375	13.167	N/A	1.250/1.249	3.27	9.25	1/4 X 1/8	2.63	3.34
GW607	6.000	N/A	4.00	6.50	16.50	N/A	1.500	3.41	11.78	3/8 X 3/16	3.00	5.28
GW707	7.000	N/A	4.32	7.59	18.91	N/A	1.625	2.97	11.50	3/8 X 3/16	2.87	6.06
GW807	8.000	N/A	4.10	8.86	20.96	N/A	1.875	2.84	12.50	1/2 X 1/4	2.81	6.22
GW1007	10.000	N/A	5.11	10.36	25.47	N/A	2.250	3.76	15.50	1/2 X 1/4	3.69	7.94

MODEL	OUTPUT FLANGE	S	U	V	X	Y	Z
327	STD	9.50	1.4375/1.4365	4.68	3/8 X 3/16	3.87	6.22
	LARGE*	9.50	1.625/1.624	4.63	3/8 X 3/16	3.69	6.37
387	STD	9.50	1.625/1.624	4.63	3/8 X 3/16	3.69	6.58
	STD	10.50	1.6875/1.6865	5.50	3/8 X 3/16	4.69	6.00
457	STD	10.50	2.1875/2.1865	5.53	1/2 X 1/4	4.63	6.25
	STD	15.50	2.438	7.63	5/8 X 5/16	6.50	7.00
GW607	STD	15.50	2.937	7.63	3/4 X 3/8	6.44	8.50
	STD	17.06	3.438	9.25	7/8 X 7/16	8.00	10.00
GW1007	STD	17.00	3.938	9.43	1 X 1/2	7.75	12.50

MODEL	OUTPUT FLANGE	A2	B2	C2	D2	E2	P2	R2	X2	Y2
327	STD	.75	11.00	9.000	4.500	9/16	4.75	5/16 NC X 1.00 DP	.75	.38
	LARGE*	.94	12.50	10.500	5.250	9/16	4.94	5/16 NC X 1.00 DP	.75	.38
387	STD	.94	12.50	10.500	5.250	9/16	4.94	5/16 NC X 1.00 DP	.75	.38
	STD	.81	14.00	12.000	6.000	11/16	5.50	3/8 NC X 1.00 DP	1.00	.50
457	STD	.84	16.00	14.000	7.000	13/16	6.63	3/8 NC X 1.00 DP	1.50	.75
	STD	1.50	19.50	17.000	8.500	15/16	9.50	3/8 NC X 1.00 DP	1.50	.75
GW607	STD	1.75	22.00	19.000	9.500	1-1/8	10.75	3/8 NC X 1.00 DP	2.00	1.00
	STD	2.00	28.00	24.000	12.000	1-5/16	13.75	5/8 NC X 1.50 DP	2.12	1.06
GW807	STD	2.25	32.00	28.000	14.000	1-5/16	17.00	5/8 NC X 1.50 DP	2.38	1.19

MODEL	AA	BB	CC	DD	EE	FF	GG	HH	JJ	KK	LL	MM	NN	WT. LBS.
327	6.250	3.125	2.750	1.375	1/2 NC	.75	.90	7.5	3.750	4.000	2.000	7/16 NC	.88	107
387	6.875	3.438	3.000	1.500	1/2 NC	.94	1.00	8.5	4.250	4.750	2.375	1/2 NC	1.00	136
457	8.125	4.063	3.250	1.625	5/8 NC	.88	1.13	N/A	N/A	N/A	N/A	N/A	N/A	176
527	9.500	4.750	3.750	1.875	5/8 NC	1.00	1.25	N/A	N/A	N/A	N/A	N/A	N/A	224
GW607	12.750	6.380	6.380	3.190	5/8 NC	1.00	1.00	N/A	N/A	N/A	N/A	N/A	N/A	363
GW707	12.500	6.250	5.500	2.750	1 NC	1.56	1.56	N/A	N/A	N/A	N/A	N/A	N/A	560
GW807	14.250	7.125	6.500	3.250	1 NC	1.66	1.66	N/A	N/A	N/A	N/A	N/A	N/A	780
GW1007	17.750	8.875	6.875	3.438	1-1/4 NC	2.04	2.04	N/A	N/A	N/A	N/A	N/A	N/A	1180

ADDITIONAL DETAIL FOR MODELS GW607 THROUGH GW1007

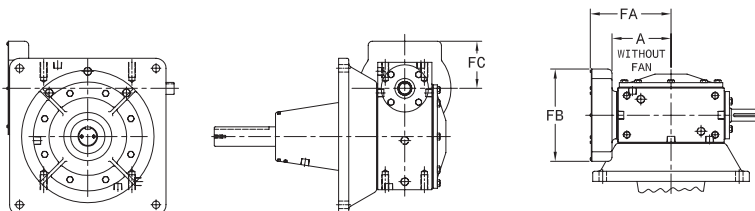

MODEL	A	FA	FB	FC
GW607	N/A	11.13	9.50	4.00
GW707	N/A	11.37	9.65	4.83
GW807	N/A	12.52	9.65	4.83
GW1007	N/A	14.69	11.28	5.62

ALL GW MODELS ARE FAN COOLED.



MODELS

328, 388, 458, 528, GW608

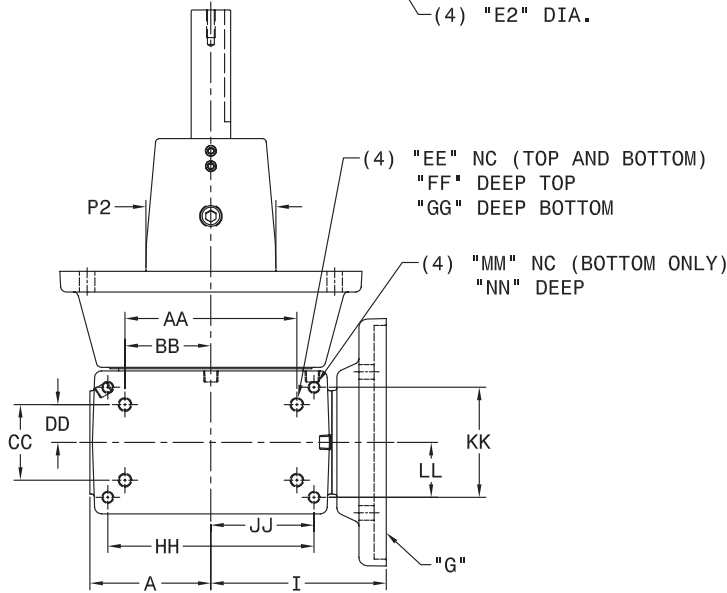
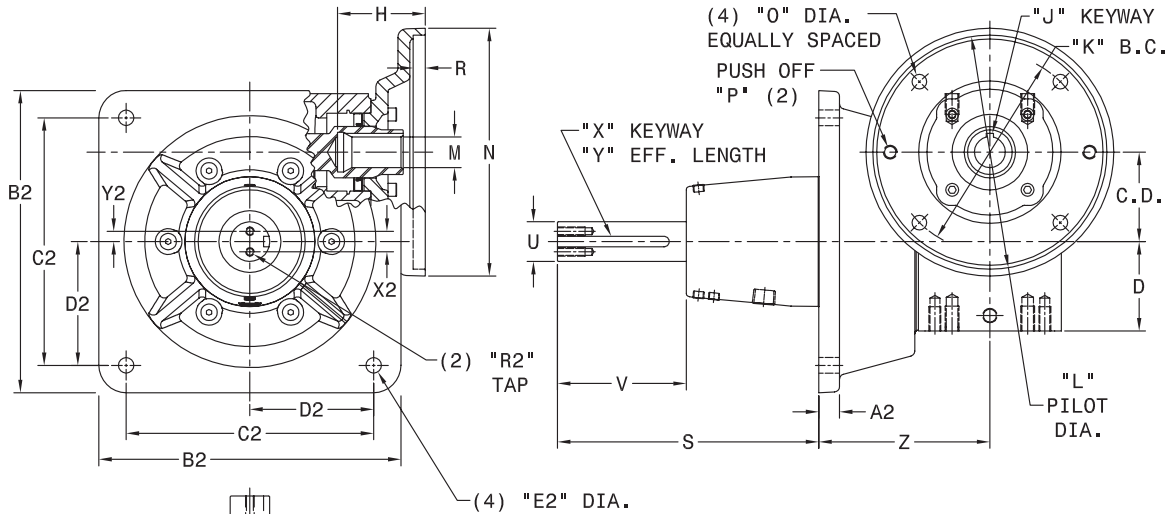

SPECIAL, 48C, METRIC AND SAE HYDRAULIC INPUT FLANGES AVAILABLE. CONSULT FACTORY FOR COMPLETE SPECIFICATIONS.

FOR LUBRICATION AND INSTALLATION INSTRUCTIONS - REFER TO SECTION R

STANDARD STYLES AVAILABLE

DIMENSIONS SHOWN ARE FOR REFERENCE ONLY. DOWNLOAD AVAILABLE CAD MODELS AT: WWW.HUBCITYINC.COM

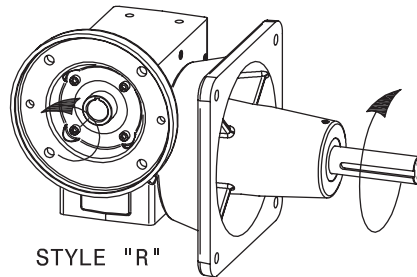
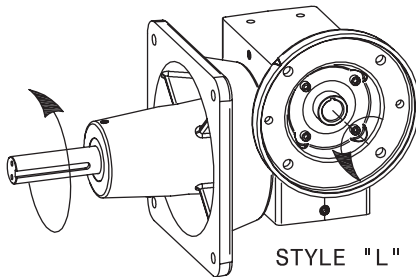

CONSULT FACTORY FOR VERTICAL SHAFT LUBRICATION RECOMMENDATIONS
INPUT SHAFT CAN BE ROTATED IN EITHER DIRECTION



MODELS

328, 388, 458, 528

B

SINGLE REDUCTION

MODEL	C.D.	A	D	G	H	I	J	K	L	M	N	O	P	R
328	3.251	4.40	3.250	56C	2.27	6.00	3/16 X 3/32	5.875	4.501/4.503	.625	5.50	13/32	SLOTS	.19
				143TC	2.38					.875				
				182TC	3.19					1.125				
388	3.751	4.90	3.937	56C	2.27	6.50	3/16 X 3/32	5.875	4.501/4.503	.625	5.50	13/32	SLOTS	.19
				143TC	2.38					.875				
				182TC	3.19					1.125				
458	4.501	5.67	4.625	56C	2.25	6.75	3/16 X 3/32	5.875	4.501/4.503	.625	6.50	13/32	SLOTS	.44
				143TC	2.25					.875				
				182TC	3.19		7.250	8.501/8.504	1.125					
				213TC	3.50				1.375					
528*	5.168	6.42	5.375	182TC	3.19	7.50	1/4 X 1/8	7.250	8.501/8.504	1.125	9.00	17/32	HOLES	.44
				213TC	3.50		5/16 X 5/32			1.375				
				254TC	3.91		3/8 X 3/16			1.625				
GW608	6.000	N/A	6.500	56C	4.42	10.45	3/16 x 3/32	5.875	4.501/4.503	0.625	6.50	13/32	HOLES	.38
				143TC	4.42	10.45	3/16 x 3/32	5.875	4.501/4.503	0.875	6.50	13/32	HOLES	.38
				182TC	3.30	9.33	1/4 x 1/8	7.250	8.501/8.504	1.125	9.00	17/32	HOLES	.50
				213TC	3.30	9.33	5/16 x 5/32	7.250	8.501/8.504	1.375	9.00	17/32	HOLES	.50
				254TC	3.91	9.94	3/8 x 3/16	7.250	8.501/8.504	1.625	9.00	17/32	HOLES	.50

* 56C & 143TC FLANGES AVAILABLE AS MODIFIED STANDARDS

MODEL	OUTPUT FLANGE	S	U	V	X	Y	Z
328	STD	9.50	1.4375/1.4365	4.68	3/8 X 3/16	3.87	6.22
	LARGE**	9.50	1.625/1.624	4.63	3/8 X 3/16	3.69	6.37
388	STD	9.50	1.625/1.624	4.63	3/8 X 3/16	3.69	6.58
458	STD	10.50	1.6875/1.6865	5.50	3/8 X 3/16	4.69	6.00
528	STD	10.50	2.1875/2.1865	5.53	1/2 X 1/4	4.63	6.25
GW608	STD	15.50	2.438	7.63	5/8 X 5/16	6.50	7.00

** LARGE FLANGE AVAILABLE AS MODIFIED STANDARD. CONSULT FACTORY

MODEL	OUTPUT FLANGE	A2	B2	C2	D2	E2	P2	R2	X2	Y2
328	STD	.75	11.00	9.000	4.500	9/16	4.75	5/16 NC X 1.00 DP	.75	.38
	LARGE**	.94	12.50	10.500	5.250	9/16	4.94	5/16 NC X 1.00 DP	.75	.38
388	STD	.94	12.50	10.500	5.250	9/16	4.94	5/16 NC X 1.00 DP	.75	.38
458	STD	.81	14.00	12.000	6.000	11/16	5.50	3/8 NC X 1.00 DP	1.00	.50
528	STD	.84	16.00	14.000	7.000	13/16	6.63	3/8 NC X 1.00 DP	1.50	.75
GW608	STD	1.50	19.50	17.000	8.500	15/16	9.50	3/8 NC X 1.00 DP	1.50	.75

** LARGE FLANGE AVAILABLE AS MODIFIED STANDARD. CONSULT FACTORY

MODEL	AA	BB	CC	DD	EE	FF	GG	HH	JJ	KK	LL	MM	NN	WT. LBS.
328	6.250	3.125	2.750	1.375	1/2 NC	.75	.90	7.500	3.750	4.000	2.000	7/16 NC	.88	117
388	6.875	3.438	3.000	1.500	1/2 NC	.94	1.00	8.500	4.250	4.750	2.375	1/2 NC	1.00	140
458	8.125	4.063	3.250	1.625	5/8 NC	.88	1.13	N/A	N/A	N/A	N/A	N/A	N/A	168
528	9.500	4.750	3.750	1.875	5/8 NC	1.00	1.25	N/A	N/A	N/A	N/A	N/A	N/A	234
GW608	12.750	6.380	6.380	3.190	5/8 NC	1.00	1.00	N/A	N/A	N/A	N/A	N/A	N/A	3730

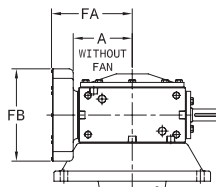
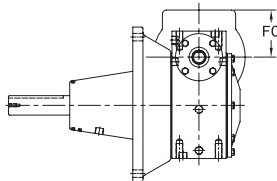
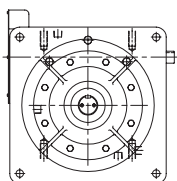

ADDITIONAL DETAIL FOR MODELS GW608

MODEL	A	FA	FB	FC
GW608	N/A	11.13	9.50	4.00

ALL GW MODELS ARE FAN COOLED.



MODELS

459V, 529V

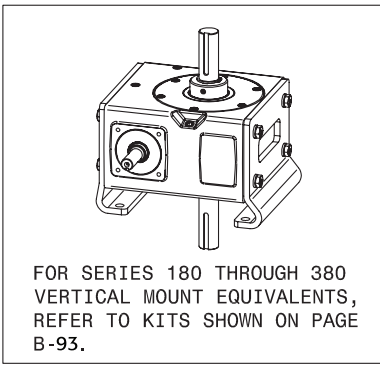
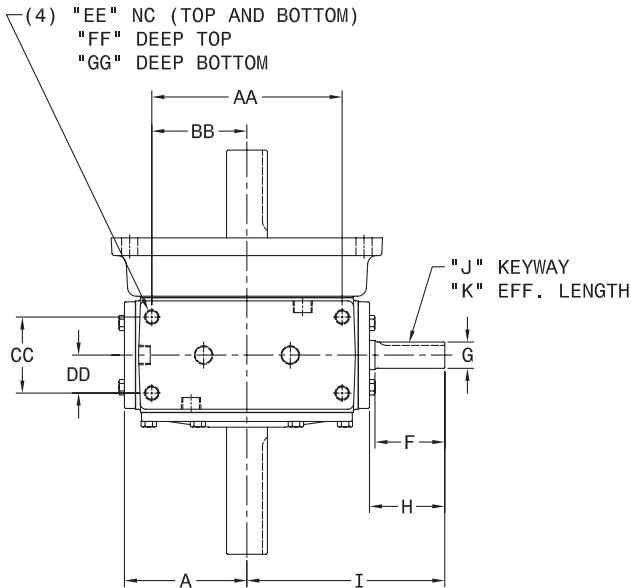
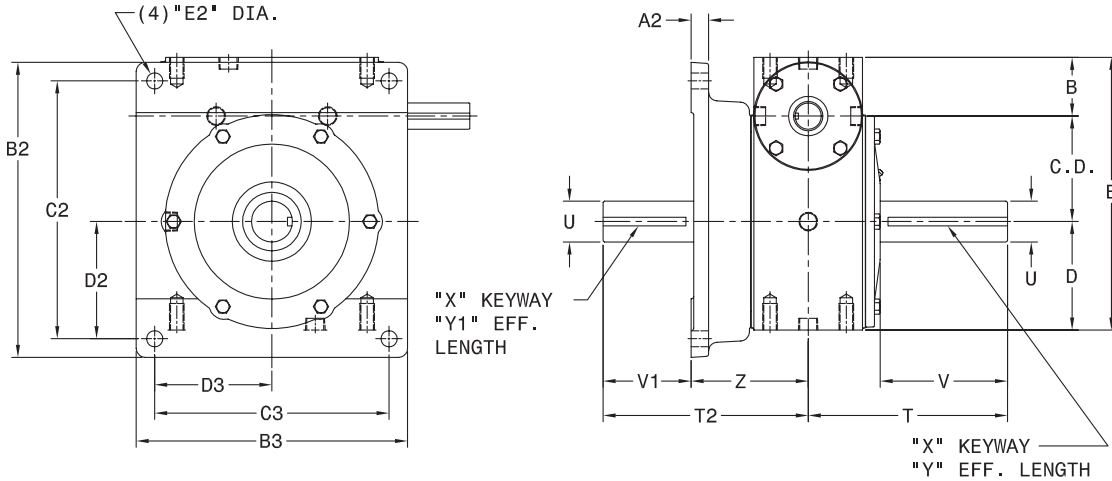

FOR LUBRICATION AND INSTALLATION INSTRUCTIONS - REFER TO SECTION R

DIMENSIONS SHOWN ARE FOR REFERENCE ONLY.
DOWNLOAD AVAILABLE CAD MODELS AT:
WWW.HUBCITYINC.COM

STANDARD STYLES AVAILABLE

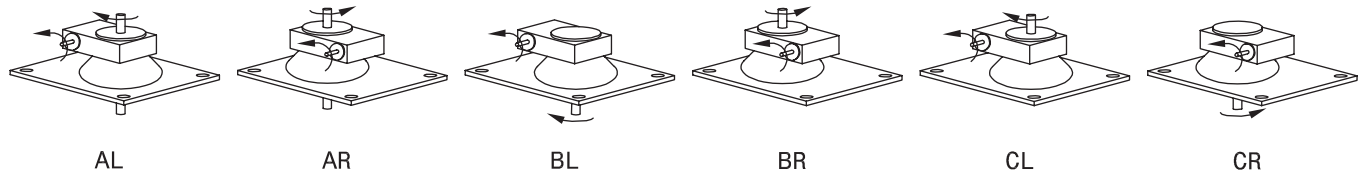

CONSULT FACTORY FOR VERTICAL SHAFT LUBRICATION RECOMMENDATIONS
INPUT SHAFT CAN BE ROTATED IN EITHER DIRECTION



MODELS
459V, 529V

B

MODEL	C.D.	A	B	D	E	F	G	H	I	J	K
459V	4.501	5.23	2.499	4.625	11.625	2.98	1.125/1.124	3.21	8.44	1/4 X 1/8	2.50
529V	5.168	5.98	2.624	5.375	13.167	N/A	1.250/1.249	3.27	9.25	1/4 X 1/8	2.63

MODEL	T	T2	U	V	V1	X	Y	Y1	Z
459V	8.50	8.75	1.750/1.749	5.43	3.75	3/8 X 3/16	4.59	3.03	5.00
529V	9.00	9.75	2.000/1.999	5.66	4.25	1/2 X 1/4	4.88	3.50	5.50

MODEL	A2	B2	B3	C2	C3	D2	D3	E2
459V	.75	12.58	11.58	11.000	10.000	5.000	5.000	11/16
529V	.75	16.83	12.58	15.250	11.000	6.750	5.500	11/16

MODEL	AA	BB	CC	DD	EE	FF	GG	WT. LBS.
459V	8.125	4.063	3.250	1.625	5/8 NC	.88	1.13	115
529V	9.500	4.750	3.750	1.875	5/8 NC	1.00	1.25	144

SINGLE REDUCTION



MODELS

450V, 520V

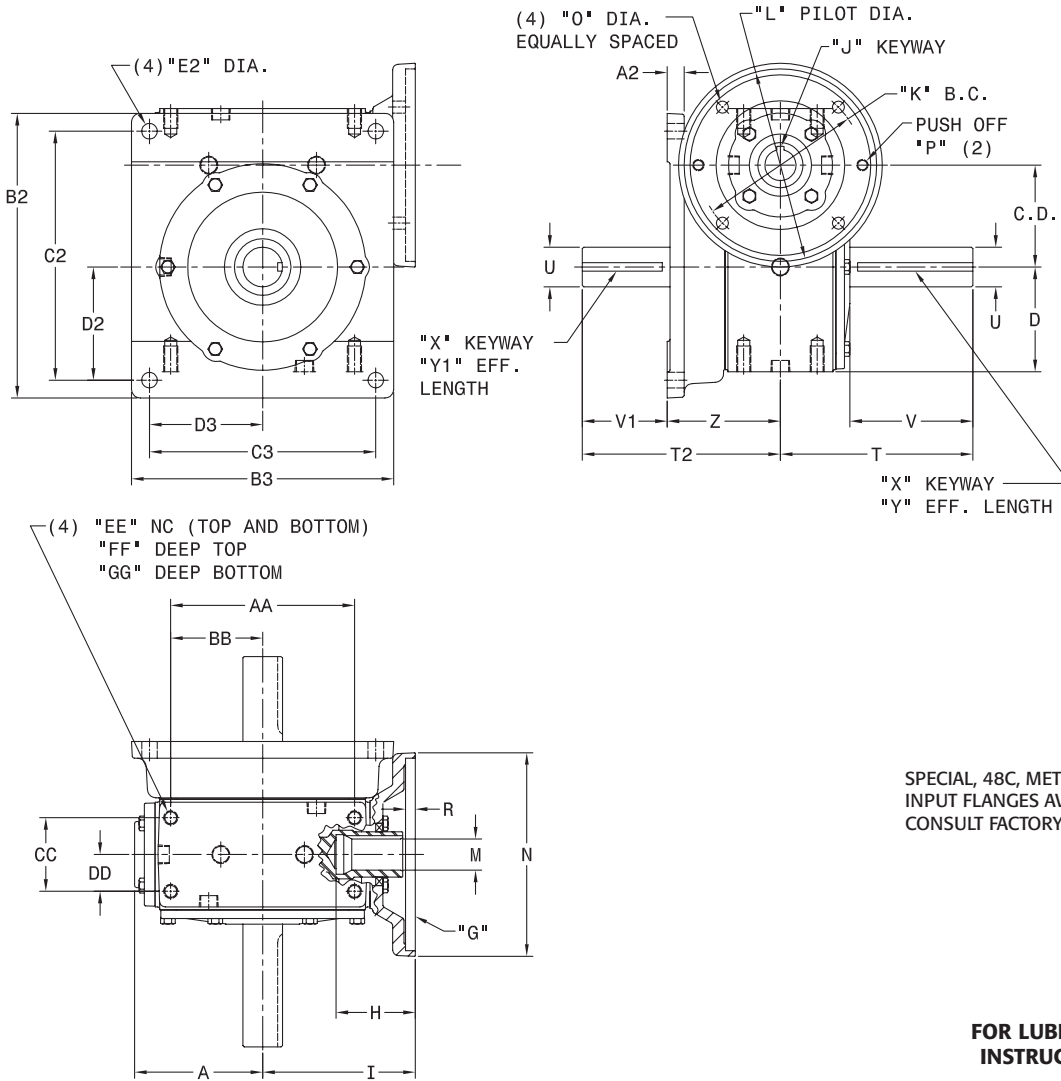

STANDARD STYLES AVAILABLE

DIMENSIONS SHOWN ARE FOR REFERENCE ONLY. CERTIFIED PRINTS ARE AVAILABLE UPON REQUEST.

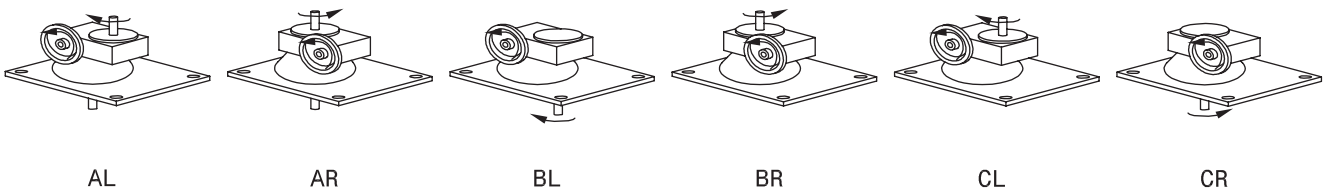

CONSULT FACTORY FOR VERTICAL SHAFT LUBRICATION RECOMMENDATIONS
INPUT SHAFT CAN BE ROTATED IN EITHER DIRECTION



MODELS
450V, 520V

B

SINGLE REDUCTION

MODEL	C.D.	A	D	G	H	I	J	K	L	M	N	O	P	R
450V	4.501	5.67	4.625	56C	2.25	6.75	3/16 X 3/32	5.875	4.501/4.503	.625	6.50	13/32	SLOTS	.44
				143TC	2.25					.875				
				182TC	3.19					1.125				
				213TC	3.50					1.375				
520V*	5.168	6.42	5.375	182TC	3.19	7.50	1/4 X 1/8	7.250	8.501/8.504	1.125	9.00	17/32	HOLES	.44
				213TC	3.50					1.375				

* 56C & 143TC FLANGES AVAILABLE AS MODIFIED STANDARDS

MODEL	T	T2	U	V	V1	X	Y	Y1	Z
450V	8.50	8.75	1.750/1.749	5.43	3.75	3/8 X 3/16	4.59	3.03	5.00
520V	9.00	9.75	2.000/1.999	5.66	4.25	1/2 X 1/4	4.88	3.50	5.50

MODEL	A2	B2	B3	C2	C3	D2	D3	E2
450V	.75	12.58	11.58	11.000	10.000	5.000	5.000	11/16
520V	.75	16.83	12.58	15.250	11.000	6.750	5.500	11/16

MODEL	AA	BB	CC	DD	EE	FF	GG	WT. LBS.
450V	8.125	4.063	3.250	1.625	5/8 NC	.88	1.13	115
520V	9.500	4.750	3.750	1.875	5/8 NC	1.00	1.25	144

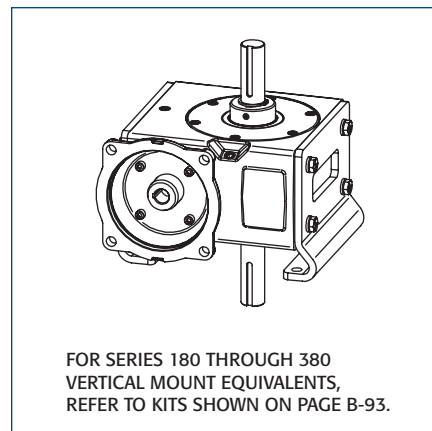



MODEL W300

Model W300 is a small, compact reducer that is adaptable to many applications in the medium horsepower range. Unit is shaft mounted for direct mounting on drive shafts. Two drilled and tapped holes on either side of housing for torque arm or other mountings.

Unit available with all cast iron alloy housings or lightweight aluminum housings.

Construction features include, tapered roller output bearings, input ball bearings, bronze worm gear, and hardened and ground worm.

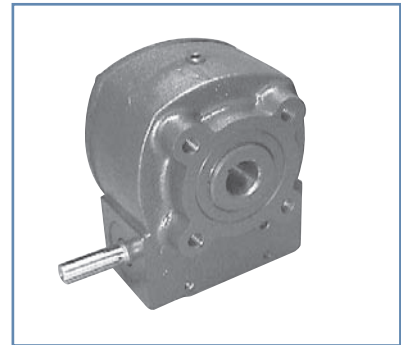

FOR LUBRICATION AND INSTALLATION INSTRUCTIONS REFER TO SECTION R.

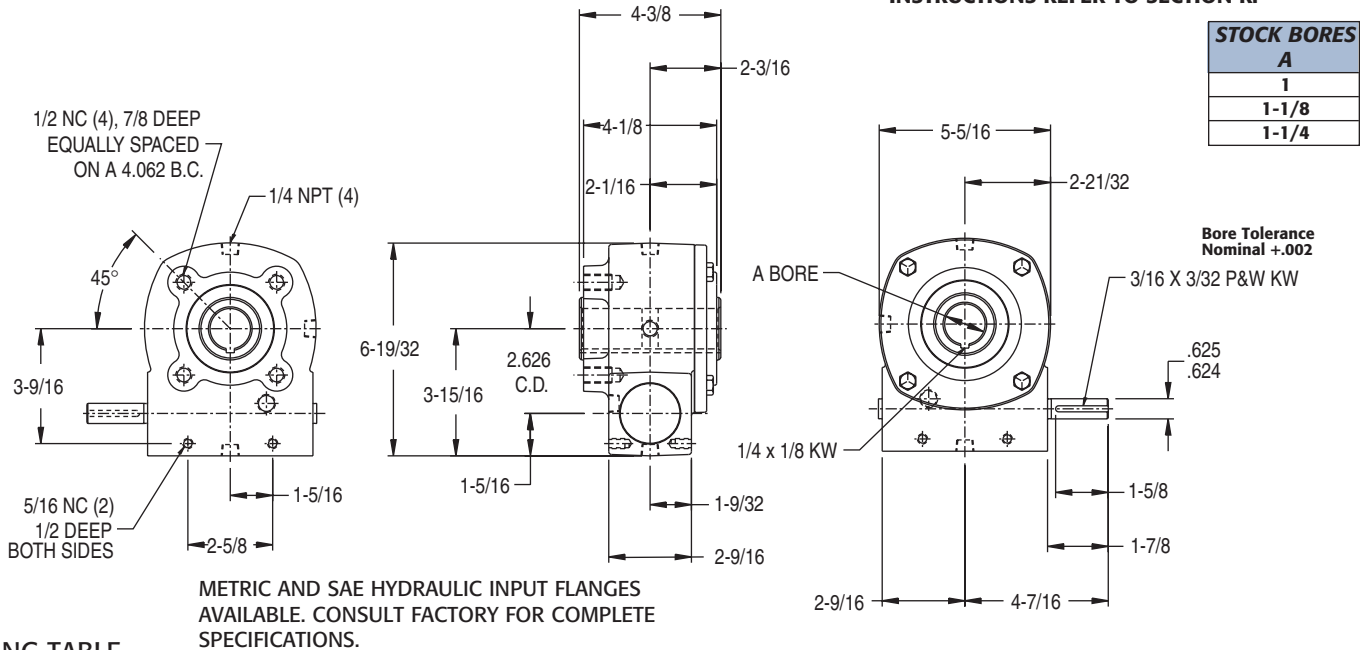

RATING TABLE

RATIO	1750 RPM INPUT			1150 RPM INPUT			850 RPM INPUT			690 RPM INPUT			100 RPM INPUT		
	INPUT HP	RPM	IN-LB TORQUE	INPUT HP	RPM	IN-LB TORQUE	INPUT HP	RPM	IN-LB TORQUE	INPUT HP	RPM	IN-LB TORQUE	INPUT HP	RPM	IN-LB TORQUE
10:1	2.45	175.0	800	1.90	115.0	960	1.55	85.0	1090	1.35	69.0	1160	.30	10.0	1650
15:1	1.56	116.6	710	1.13	76.6	845	1.01	56.6	980	.84	46.0	1055	.25	6.6	1560
20:1	1.33	87.5	870	1.02	57.5	1020	.83	42.5	1160	.74	34.5	1220	.23	5.0	1750
25:1	1.04	70.0	865	.84	46.0	1050	.64	34.0	1070	.60	27.6	1160	.14	4.0	1410
30:1	.94	58.3	730	.68	38.3	870	.60	28.3	1015	.51	23.0	1090	.15	3.3	1600
40:1	.71	43.7	820	.54	28.8	1000	.46	21.2	1130	.41	17.2	1200	.13	2.5	1690
50:1	.53	35.0	760	.42	23.0	930	.36	17.0	1060	.31	13.8	1140	.08	2.0	1540
60:1	.50	29.2	640	.42	19.1	840	.35	14.1	990	.30	11.5	1075	.08	1.6	1350

STANDARD STYLES AVAILABLE

DIMENSIONS SHOWN ARE FOR REFERENCE ONLY. CERTIFIED PRINTS ARE AVAILABLE UPON REQUEST.

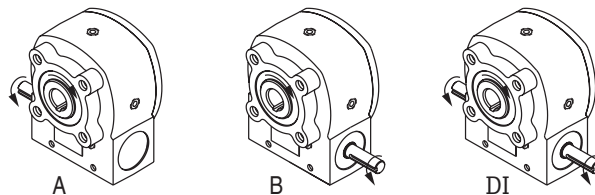

CONSULT FACTORY FOR VERTICAL SHAFT LUBRICATION RECOMMENDATIONS
 INPUT SHAFT CAN BE ROTATED IN EITHER DIRECTION



MODEL W50B

Model W50B worm gear reducers are sturdily built, compact, and have a high torque capacity. Output sleeve has hollow bore for direct mounting on driven shaft.

Tapered roller bearings and bronze worm gear for improved efficiency and smooth operation.

Construction with all cast alloy iron housings; heavy-duty industrial seals.

Factory installed "C" flanges are available on special order.



FOR LUBRICATION AND INSTALLATION INSTRUCTIONS REFER TO SECTION R.

B
SINGLE REDUCTION

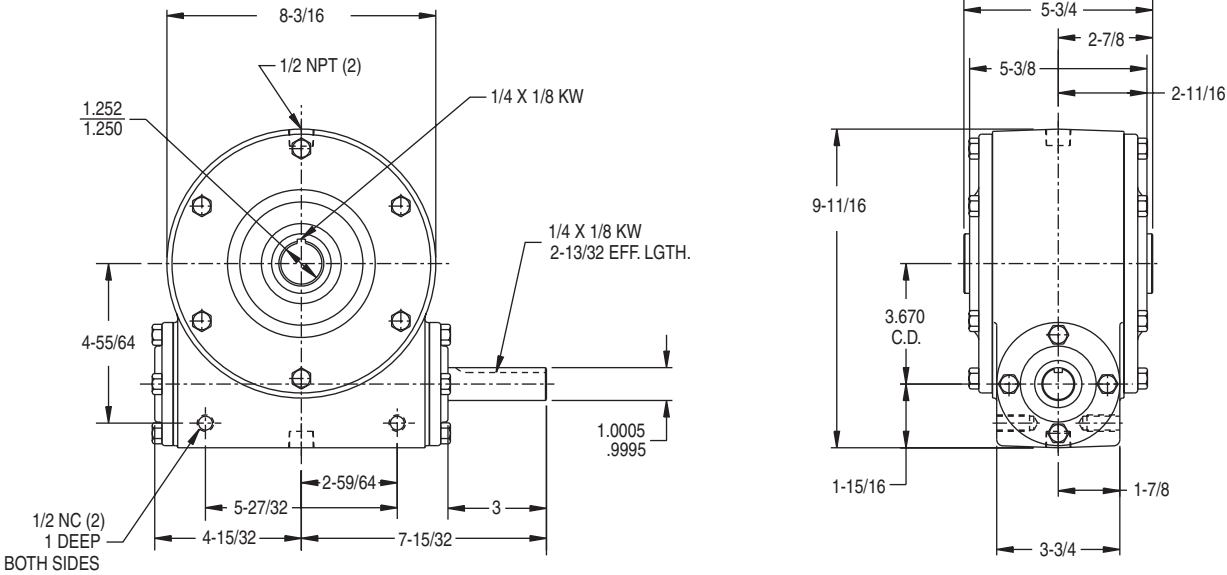

RATING TABLE

RATIO	1750 RPM INPUT			1150 RPM INPUT			850 RPM INPUT			690 RPM INPUT			100 RPM INPUT		
	INPUT HP	RPM	IN-LB TORQUE	INPUT HP	RPM	IN-LB TORQUE	INPUT HP	RPM	IN-LB TORQUE	INPUT HP	RPM	IN-LB TORQUE	INPUT HP	RPM	IN-LB TORQUE
8:1	5.5	218.0	1510	4.4	144.0	1860	3.8	106.0	2170	3.4	86.0	2360	.80	12.5	3790
16:1	3.2	109.0	1690	2.6	72.0	2110	2.0	53.0	2420	1.9	43.0	2640	.45	6.25	4180
32:1	1.7	54.7	1640	1.4	36.0	2600	1.2	26.5	2360	1.1	21.5	2590	.25	3.12	4030

DIMENSIONS SHOWN ARE FOR REFERENCE ONLY. CERTIFIED PRINTS ARE AVAILABLE UPON REQUEST.

STANDARD STYLES AVAILABLE

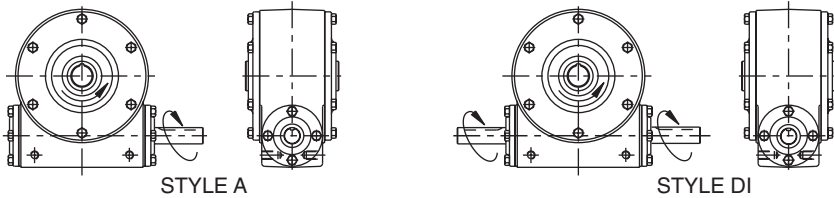

CONSULT FACTORY FOR VERTICAL SHAFT LUBRICATION RECOMMENDATIONS
INPUT SHAFT CAN BE ROTATED IN EITHER DIRECTION



MODEL W516

Model W516 is ideally suited for apron drive applications on spreader wagons, bulk feed boxes, etc.

Constructed with all alloy cast iron housings, tapered roller bearings, and industrial type oil seals. Totally enclosed for oil lubrication.

Unit available with either bronze or cast iron worm gear. Also available with output shaft extensions or hollow bore for shaft mounting. Four mounting pads on either side of the housing are drilled and tapped 1/2" NC for direct mounting.

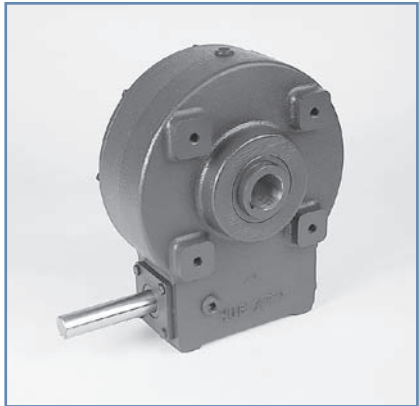

FOR LUBRICATION AND INSTALLATION INSTRUCTIONS REFER TO SECTION R.

RATING TABLE

MODEL	RATIO	1750 RPM INPUT			1150 RPM INPUT			850 RPM INPUT			690 RPM INPUT			100 RPM INPUT		
		INPUT HP	RPM	IN-LB TORQUE	INPUT HP	RPM	IN-LB TORQUE	INPUT HP	RPM	IN-LB TORQUE	INPUT HP	RPM	IN-LB TORQUE	INPUT HP	RPM	IN-LB TORQUE
W516 BRONZE GEAR	*12.5:1	12.7	140	5267	10.5	92	6576	9.4	68	7878	8.5	55.2	8677	1.8	8	12,289
	25:1	7.2	70	5654	6.1	46	7110	5.4	34	8378	4.9	27.6	9225	1.2	4	13,077
	50:1	4.2	35	5402	3.6	23	7343	3.2	17	8890	2.9	13.8	9819	.68	2	14,495
W516 CAST IRON GEAR	*12.5:1							5.1	68	4016	4.5	55.2	4262	1.0	8	5909
	25:1							2.8	34	3891	2.5	27.6	4167	.55	4	5460
	50:1							1.5	17	3613	1.3	13.8	3740	.25	2	3939

*MFG. TO ORDER - CONSULT FACTORY FOR PRICE AND DELIVERY

W516 SOLID SHAFT OUTPUT

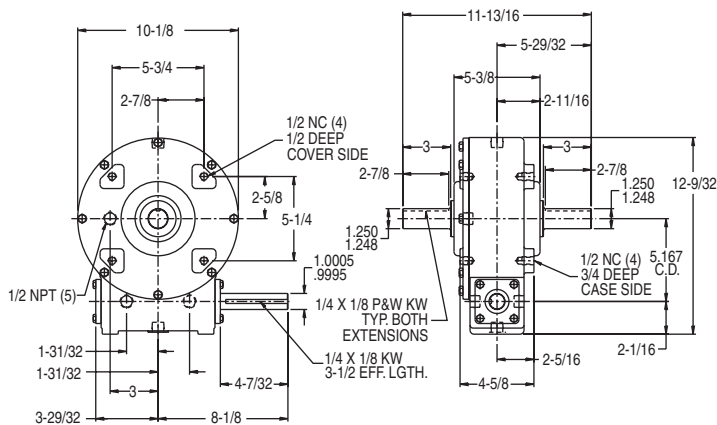

STYLES AVAILABLE

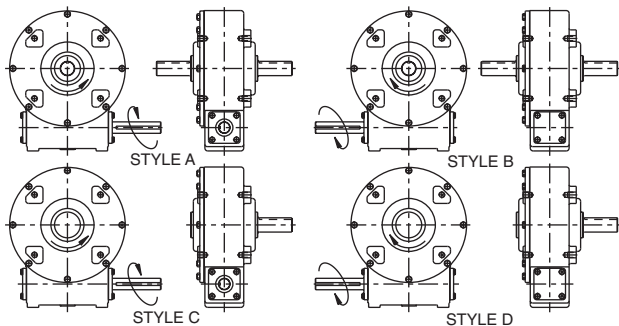

W516 HOLLOW BORE OUTPUT

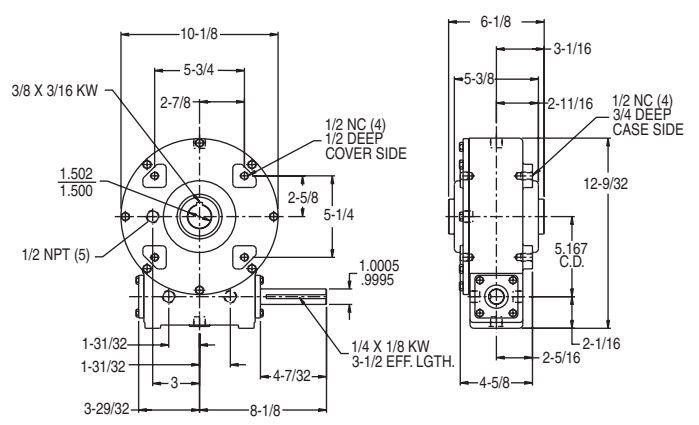

STYLES AVAILABLE

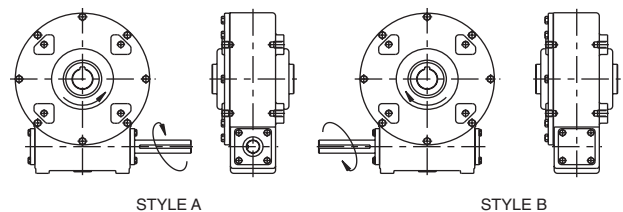

DIMENSIONS SHOWN ARE FOR REFERENCE ONLY. CERTIFIED PRINTS ARE AVAILABLE UPON REQUEST.



MODELS RM1, RM2, RM3 - HELICAL RATIO MULTIPLIERS

FEATURES

- Three Cast Iron Models, Two Aluminum Models, One Stainless Steel Model (See Section O)
- Ratios available from 2:1 to 7.5:1
- Can be used as reducer or increaser.
- Provides additional reduction capability when mounted onto Helical Gear Reducer or Worm Gear Reducer
- C-flange or solid input shaft.
- Helical gearing.
- Double lip seals.
- Base mounting available.
- Permanently lubricated at factory.



SINGLE REDUCTION UNITS PROVIDE OPPOSITE DIRECTION OUTPUT ROTATION

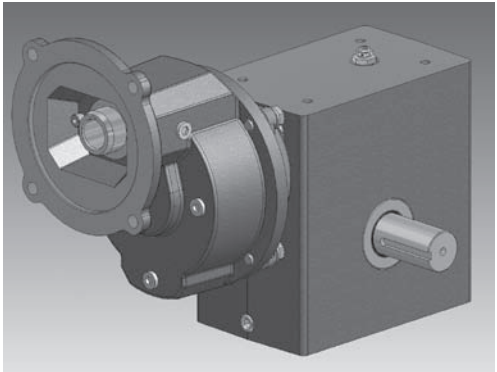

MODEL NOMENCLATURE EXAMPLE

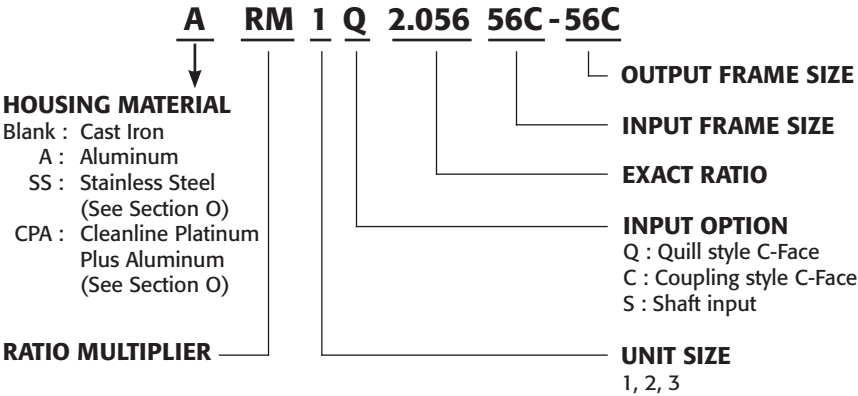

Helical Ratio Multipliers, when coupled with a C-faced single reduction worm speed reducer (see illustration) can create an efficient helical-worm double reduction speed reducer combination. Please refer to rating chart example below for selection instructions.

Note: See Section F for dimensions and available frame sizes of Helical ratio multipliers and pages B-32 to B-47 for dimensions and available frame sizes of single reduction units

Also see Section F for ratings of Helical Ratio multipliers as stand alone parallel shaft reducers.

Selection Example: (see next page for rating chart)

HELICAL-WORM DOUBLE REDUCTION MECHANICAL RATINGS

RATINGS @ 1750 INPUT RPM, 1.00 SERVICE FACTOR

USE THIS CHART WHEN COUPLING A HELICAL RATIO MULTIPLIER WITH A SINGLE REDUCTION WORM SPEED REDUCER

TOTAL RATIO	OUTPUT RPM	WORM SERIES	WORM RATIO	HELICAL SIZE	HELICAL RATIO	INPUT HP	EFF. %	OUTPUT TORQUE
40.00	43.8	240	10	RM1	4.00	2.20	79.1	1613
40.00	43.8	260	10	RM2	4.00	2.20	78.1	2539
40.00	43.8	320	10	RM2	4.00	3.63	77.8	4070
40.45	43.3	380	10	RM3	4.05	6.29	79.2	7257
			10	RM3	4.05	8.80	80.2	11029
			10	RM1			72.1	378
			10	RM1	5.11	0.64	73.2	862
51.11	34.2	210	10	RM1	5.11	0.99	73.6	1340

1. Select Total Ratio Desired

2. Select by Input HP or Output Tq required for your application

3. Order C-face model of worm gear drive in series and ratio listed here. (See page B-12)

4. Order RM model and ratio listed here

NOTE: **INPUT** FRAME SIZE OF Worm speed reducer MUST match **OUTPUT** frame size of Helical ratio multiplier. (See dimensional pages reference above for available frame sizes)

B
SINGLE REDUCTION



HELICAL-WORM DOUBLE REDUCTION MECHANICAL RATINGS

RATINGS @ 1750 INPUT RPM, 1.00 SERVICE FACTOR

USE THIS CHART WHEN COUPLING A HELICAL RATIO MULTIPLIER WITH A SINGLE REDUCTION WORM SPEED REDUCER

TOTAL RATIO	OUTPUT RPM	WORM SERIES	WORM RATIO	HELICAL SIZE	HELICAL RATIO	INPUT HP	EFF. %	OUTPUT TORQUE
40.00	43.8	130	10	RM1	4.00	0.34	73.0	359
40.00	43.8	180	10	RM1	4.00	0.76	74.1	814
40.00	43.8	210	10	RM1	4.00	1.17	74.5	1254
40.00	43.8	W240	10	RM1	4.00	1.42	79.1	1613
40.00	43.8	260	10	RM2	4.00	2.26	78.1	2539
40.00	43.8	320	10	RM2	4.00	3.63	77.8	4070
40.45	43.3	380	10	RM3	4.05	6.29	79.2	7257
40.45	43.3	450	10	RM3	4.05	9.44	80.2	11029
40.45	43.3	520	10	RM3	4.05	11.35	81.2	13420
51.11	34.2	130	10	RM1	5.11	0.28	72.1	378
51.11	34.2	180	10	RM1	5.11	0.64	73.2	862
51.11	34.2	210	10	RM1	5.11	0.99	73.6	1340
51.11	34.2	W240	10	RM1	5.11	1.16	78.4	1680
50.00	35.0	260	10	RM2	5.00	1.91	77.3	2654
50.00	35.0	320	10	RM2	5.00	3.00	76.8	4150
51.67	33.9	380	10	RM3	5.17	5.43	78.4	7914
51.67	33.9	450	10	RM3	5.17	8.18	79.4	12091
51.67	33.9	520	10	RM3	5.17	10.07	80.4	15070
60.00	29.2	130	15	RM1	4.00	0.27	67.2	392
60.00	29.2	180	15	RM1	4.00	0.57	68.6	838
60.00	29.2	210	15	RM1	4.00	0.90	68.4	1324
60.00	29.2	W240	15	RM1	4.00	1.06	74.7	1711
60.00	29.2	260	15	RM2	4.00	1.83	71.1	2812
60.00	29.2	320	15	RM2	4.00	3.30	73.2	5214
60.68	28.8	380	15	RM3	4.05	4.64	74.6	7564
60.68	28.8	450	15	RM3	4.05	7.07	76.0	11728
60.68	28.8	520	15	RM3	4.05	5.80	77.4	12410
74.62	23.5	130	10	RM1	7.46	0.20	70.5	379
74.62	23.5	180	10	RM1	7.46	0.45	71.4	870
74.62	23.5	210	10	RM1	7.46	0.71	71.6	1366
74.62	23.5	W240	10	RM1	7.46	0.83	77.1	1722
71.82	24.4	260	10	RM2	7.18	1.36	75.7	2662
71.82	24.4	320	10	RM2	7.18	2.62	75.0	5070
75.38	23.2	380	10	RM3	7.54	3.97	76.6	8256
75.38	23.2	450	10	RM3	7.54	5.80	77.7	12240
77.51	22.6	520	15	RM3	5.17	8.72	76.5	18615
80.00	21.9	130	20	RM1	4.00	0.21	64.1	385
80.00	21.9	180	20	RM1	4.00	0.46	65.5	861
80.00	21.9	210	20	RM1	4.00	0.66	65.7	1253
80.00	21.9	W240	20	RM1	4.00	0.84	71.3	1730
80.00	21.9	260	20	RM2	4.00	1.36	69.8	2733
80.00	21.9	320	20	RM2	4.00	2.62	69.5	5235
80.90	21.6	380	20	RM3	4.05	3.69	72.0	7746
80.90	21.6	450	20	RM3	4.05	5.63	73.6	12058
80.90	21.6	520	20	RM3	4.05	7.69	75.4	16891
87.87	19.9	130	30	RM1	2.93	0.22	55.6	382
87.87	19.9	180	30	RM1	2.93	0.45	57.5	810
87.87	19.9	210	30	RM1	2.93	0.70	57.3	1265
87.87	19.9	W240	30	RM1	2.93	0.79	65.8	1647
87.39	20.0	260	30	RM2	2.91	1.38	60.9	2656
87.39	20.0	320	30	RM2	2.91	2.36	63.8	4734
87.39	20.0	380	30	RM2	2.91	3.30	65.8	6841
88.92	19.7	450	30	RM3	2.96	5.02	67.9	10899
88.92	19.7	520	30	RM3	2.96	7.01	70.0	15704

CONTINUED ON NEXT PAGE



HELICAL-WORM DOUBLE REDUCTION MECHANICAL RATINGS

RATINGS @ 1750 INPUT RPM, 1.00 SERVICE FACTOR

USE THIS CHART WHEN COUPLING A HELICAL RATIO MULTIPLIER WITH A SINGLE REDUCTION WORM SPEED REDUCER

TOTAL RATIO	OUTPUT RPM	WORM SERIES	WORM RATIO	HELICAL SIZE	HELICAL RATIO	INPUT HP	EFF. %	OUTPUT TORQUE
102.22	17.1	130	20	RM1	5.11	0.17	63.0	405
102.22	17.1	180	20	RM1	5.11	0.38	64.4	910
102.22	17.1	210	20	RM1	5.11	0.55	64.5	1305
102.22	17.1	W240	20	RM1	5.11	0.70	70.3	1802
100.00	17.5	260	20	RM2	5.00	1.15	68.7	2852
100.00	17.5	320	20	RM2	5.00	2.23	68.2	5488
100.00	17.5	380	20	RM2	5.00	3.04	70.9	7758
103.34	16.9	450	20	RM3	5.17	4.82	72.5	13009
103.34	16.9	520	20	RM3	5.17	6.66	74.4	18447
120.00	14.6	130	30	RM1	4.00	0.17	53.5	399
120.00	14.6	180	30	RM1	4.00	0.36	55.3	850
120.00	14.6	210	30	RM1	4.00	0.56	54.9	1339
120.00	14.6	W240	30	RM1	4.00	0.63	63.9	1729
120.00	14.6	260	30	RM2	4.00	1.13	58.5	2846
120.00	14.6	320	30	RM2	4.00	1.98	61.3	5256
120.00	14.6	380	30	RM2	4.00	2.76	63.4	7557
121.35	14.4	450	30	RM3	4.05	4.16	65.5	11900
121.35	14.4	520	30	RM3	4.05	5.82	67.7	17210
149.24	11.7	130	20	RM1	7.46	0.12	61.0	404
149.24	11.7	180	20	RM1	7.46	0.27	62.2	913
149.24	11.7	210	20	RM1	7.46	0.38	62.1	1281
149.24	11.7	W240	20	RM1	7.46	0.50	68.5	1840
143.64	12.2	260	20	RM2	7.18	0.83	66.5	2851
143.64	12.2	320	20	RM2	7.18	1.60	65.7	5439
143.64	12.2	380	20	RM2	7.18	2.11	68.5	7461
150.76	11.6	450	20	RM3	7.54	3.46	70.2	13194
150.76	11.6	520	20	RM3	7.54	4.84	72.2	18987
160.00	10.9	130	40	RM1	4.00	0.13	49.6	379
160.00	10.9	180	40	RM1	4.00	0.29	51.2	843
160.00	10.9	210	40	RM1	4.00	0.42	51.4	1256
160.00	10.9	W240	40	RM1	4.00	0.50	58.8	1698
160.00	10.9	260	40	RM2	4.00	0.82	56.8	2674
160.00	10.9	320	40	RM2	4.00	1.61	56.2	5215
160.00	10.9	380	40	RM2	4.00	2.23	59.6	7664
161.80	10.8	450	40	RM3	4.05	3.31	62.0	11961
161.80	10.8	520	40	RM3	4.05	4.42	64.5	16613
204.44	8.6	130	40	RM1	5.11	0.11	48.3	399
204.44	8.6	180	40	RM1	5.11	0.24	49.9	892
204.44	8.6	210	40	RM1	5.11	0.36	49.9	1337
204.44	8.6	W240	40	RM1	5.11	0.42	57.5	1770
200.00	8.8	260	40	RM2	5.00	0.70	55.4	2780
200.00	8.8	320	40	RM2	5.00	1.39	54.6	5461
200.00	8.8	380	40	RM2	5.00	1.85	58.1	7748
200.00	8.8	450	40	RM2	5.00	2.89	60.4	12567
206.68	8.5	520	40	RM3	5.17	3.87	63.1	18150
255.55	6.8	130	50	RM1	5.11	0.09	42.3	341
255.55	6.8	180	50	RM1	5.11	0.21	44.0	845
255.55	6.8	210	50	RM1	5.11	0.24	46.3	1020
255.55	6.8	W240	50	RM1	5.11	0.31	53.6	1512
250.00	7.0	260	50	RM2	5.00	0.40	53.4	1912
250.00	7.0	320	50	RM2	5.00	0.96	50.2	4327
250.00	7.0	380	50	RM2	5.00	1.21	54.2	5917
250.00	7.0	450	50	RM2	5.00	1.97	56.7	10058
250.00	7.0	520	50	RM2	5.00	2.75	59.1	14654

CONTINUED ON NEXT PAGE



HELICAL-WORM DOUBLE REDUCTION MECHANICAL RATINGS

RATINGS @ 1750 INPUT RPM, 1.00 SERVICE FACTOR

USE THIS CHART WHEN COUPLING A HELICAL RATIO MULTIPLIER WITH A SINGLE REDUCTION WORM SPEED REDUCER

TOTAL RATIO	OUTPUT RPM	WORM SERIES	WORM RATIO	HELICAL SIZE	HELICAL RATIO	INPUT HP	EFF. %	OUTPUT TORQUE
298.48	5.9	130	40	RM1	7.46	0.08	46.0	397
298.48	5.9	180	40	RM1	7.46	0.18	47.3	893
298.48	5.9	210	40	RM1	7.46	0.27	47.1	1348
298.48	5.9	W240	40	RM1	7.46	0.30	55.1	1801
287.28	6.1	260	40	RM2	7.18	0.50	52.6	2730
287.28	6.1	320	40	RM2	7.18	1.01	51.5	5381
287.28	6.1	380	40	RM2	7.18	1.30	55.0	7409
287.28	6.1	450	40	RM2	7.18	2.12	57.3	12569
287.28	6.1	520	40	RM2	7.18	2.86	60.1	17784
373.10	4.7	130	50	RM1	7.46	0.06	40.0	332
373.10	4.7	180	50	RM1	7.46	0.15	41.5	819
373.10	4.7	210	50	RM1	7.46	0.17	43.6	988
373.10	4.7	W240	50	RM1	7.46	0.22	51.3	1496
359.10	4.9	260	50	RM2	7.18	0.28	50.8	1827
359.10	4.9	320	50	RM2	7.18	0.68	47.0	4114
359.10	4.9	380	50	RM2	7.18	0.85	51.1	5635
359.10	4.9	450	50	RM2	7.18	1.39	53.5	9587
359.10	4.9	520	50	RM2	7.18	1.94	56.1	14045
447.72	3.9	130	60	RM1	7.46	0.06	29.1	279
447.72	3.9	180	60	RM1	7.46	0.11	36.6	659
447.72	3.9	210	60	RM1	7.46	0.15	37.0	895
447.72	3.9	W240	60	RM1	7.46	0.15	49.6	1178
430.92	4.1	260	60	RM2	7.18	0.33	39.0	2023
430.92	4.1	320	60	RM2	7.18	0.49	43.0	3301
430.92	4.1	380	60	RM2	7.18	0.85	51.1	6762
430.92	4.1	450	60	RM2	7.18	0.99	49.9	7627
430.92	4.1	520	60	RM2	7.18	1.36	52.9	11176



DOUBLE REDUCTION

B

For Compact Light Weight Aluminum Worm Gear Drives
See Spartan™ Worm Gear Drives

Section C

For High Efficiency
Right Angle Gear Drives
See Poweratio® 2000
Helical Bevel and Helical Worm Units

Sections K & L









For Available Electric Motors

Section H

DOUBLE REDUCTION

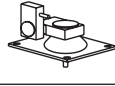
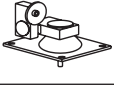
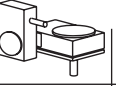

MODEL INDEX

SERIES										
1300	1301 PAGE B-62,B-63			1304 PAGE B-70,B-71						
1800	1801 PAGE B-62,B-63	1802 PAGE B-64,B-65	1803 PAGE B-66,B-67	1804 PAGE B-70,B-71	1805 PAGE B-72,B-73	1806 PAGE B-74,B-75			1809 SEE PAGE B-93	1810 SEE PAGE B-93
2100	2101 PAGE B-62,B-63	2102 PAGE B-64,B-65	2103 PAGE B-66,B-67	2104 PAGE B-70,B-71	2105 PAGE B-72,B-73	2106 PAGE B-74,B-75			2109 SEE PAGE B-93	2110 SEE PAGE B-93
2400	2401 PAGE B-62,B-63	2402 PAGE B-64,B-65	2403 PAGE B-66,B-67	2404 PAGE B-70,B-71	2405 PAGE B-72,B-73	2406 PAGE B-74,B-75			2409 SEE PAGE B-93	2410 SEE PAGE B-93
2600	2601 PAGE B-62,B-63	2602 PAGE B-64,B-65	2603 PAGE B-66,B-67	2604 PAGE B-70,B-71	2605 PAGE B-72,B-73	2606 PAGE B-74,B-75			2609 SEE PAGE B-93	2610 SEE PAGE B-93
3200	3201 PAGE B-62,B-63	3202 PAGE B-64,B-65	3203 PAGE B-66,B-67	3204 PAGE B-70,B-71	3205 PAGE B-72,B-73	3206 PAGE B-74,B-75	3207 PAGE B-78,B-79	3208 PAGE B-80,B-81	3209 SEE PAGE B-93	3210 SEE PAGE B-93
3800	3801 PAGE B-62,B-63	3802 PAGE B-64,B-65	3803 PAGE B-66,B-67	3804 PAGE B-70,B-71	3805 PAGE B-72,B-73	3806 PAGE B-74,B-75	3807 PAGE B-78,B-79	3808 PAGE B-80,B-81	3809 SEE PAGE B-93	3810 SEE PAGE B-93
4500	4501 PAGE B-62,B-63	4502 PAGE B-64,B-65	4503 PAGE B-68,B-69	4504 PAGE B-70,B-71	4505 PAGE B-72,B-73	4506 PAGE B-76,B-77	4507 PAGE B-78,B-79	4508 PAGE B-80,B-81	4509 PAGE B-82,B-83	4510 PAGE B-84,B-85
5200	5201 PAGE B-62,B-63	5202 PAGE B-64,B-65	5203 PAGE B-68,B-69	5204 PAGE B-70,B-71	5205 PAGE B-72,B-73	5206 PAGE B-76,B-77	5207 PAGE B-78,B-79	5208 PAGE B-80,B-81	5209 PAGE B-82,B-83	5210 PAGE B-84,B-85
GW60D	GW6001 PAGE B-62,B-63	GW6002 PAGE B-64,B-65		GW6004 PAGE B-70,B-71	GW6005 PAGE B-72,B-73		GW6007 PAGE B-78,B-79	GW6008 PAGE B-80,B-81		
GW70D	GW7001 PAGE B-62,B-63	GW7002 PAGE B-64,B-65		GW7004 PAGE B-70,B-71	GW7005 PAGE B-72,B-73		GW7007 PAGE B-78,B-79	GW7008 PAGE B-80,B-81		
GW80D	GW8001 PAGE B-62,B-63	GW8002 PAGE B-64,B-65		GW8004 PAGE B-70,B-71	GW8005 PAGE B-72,B-73		GW8007 PAGE B-78,B-79	GW8008 PAGE B-80,B-81		
GW100D	GW10001 PAGE B-62,B-63	GW10002 PAGE B-64,B-65		GW10004 PAGE B-70,B-71	GW10005 PAGE B-72,B-73		GW10007 PAGE B-78,B-79	GW10008 PAGE B-80,B-81		

FOR ACCESSORIES REFER TO PAGE B-87 THRU B-97

LUBRICATION AND MOUNTING POSITIONS

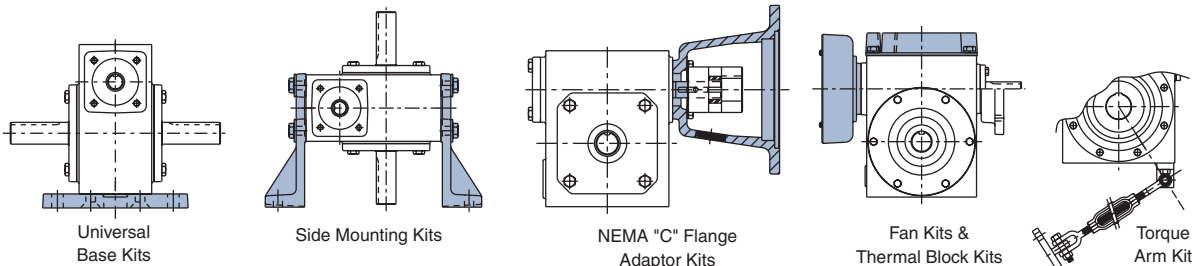

FOLLOW THE LUBRICATION INSTRUCTIONS THAT ARE FURNISHED FOR THE PRIMARY, AND FINAL DRIVE OF YOUR HUB CITY DOUBLE REDUCTION WORM GEAR REDUCER.

THE TWO UNITS THAT MAKE UP THE DOUBLE REDUCTION ASSEMBLY HAVE INDEPENDENT OIL RESERVOIRS AND EACH MUST BE FILLED TO THE SPECIFIED LEVEL OF OIL INDICATED IN THE LUBRICATION INSTRUCTIONS.

CAUTION – THE DOUBLE REDUCTION WORM GEAR REDUCER MAY BE MOUNTED IN VIRTUALLY ANY POSITION. HOWEVER, IF THE FINAL MOUNTING POSITION IS SUCH THAT ANY OF THE SHAFTS IS IN A VERTICAL POSITION, IT IS SUGGESTED THAT YOU CONSULT THE FACTORY OR YOUR HUB CITY DISTRIBUTOR FOR SPECIAL LUBRICATION INSTRUCTIONS.



UNIVERSAL POWER CUBE CATALOG RATINGS

SERIES 1300, 1800 & 2100

	INPUT RPM	RATIO	OUTPUT RPM	RATIO COMB.		CONVENTIONAL OIL						PAO SYNTHETIC OIL				PAG SYNTHETIC OIL		
				PRIM. RATIO	SEC. RATIO	MECH. INPUT HP	EFF. %	MECH. OUTPUT TORQUE	THERMAL INPUT HP	THERMAL OUTPUT TORQUE	EFF. %	MECH. OUTPUT TORQUE	THERMAL INPUT HP	THERMAL OUTPUT TORQUE	EFF. %	INPUT HP	OUTPUT TORQUE	
SERIES 1300 RATINGS	1750	50	35.0	5	10	0.316	64.2	366	ALL	ALL	68.7	392	ALL	ALL	73.5	0.316	419	
		75	23.3	5	15	0.251	58.9	400	RATIOS	RATIOS	63.2	429	RATIOS	RATIOS	67.8	0.251	460	
		100	17.5	5	20	0.194	56.1	392	THERMAL	THERMAL	60.1	420	THERMAL	THERMAL	64.6	0.194	451	
		150	11.7	10	15	0.146	52.6	416	EQUALS	EQUALS	56.6	448	EQUALS	EQUALS	61.2	0.146	484	
		200	8.75	10	20	0.113	49.8	407	MECH.	MECH.	53.6	438	MECH.	MECH.	57.9	0.113	473	
		250	7.00	5	50	0.093	38.2	321			42.6	357			45.7	0.093	384	
		300	5.83	20	15	0.085	46.3	424			49.9	457			54.0	0.085	495	
		400	4.38	20	20	0.066	43.6	414			47.0	446			51.0	0.066	484	
		500	3.50	50	10	0.060	36.6	394			39.9	429			43.1	0.060	463	
		600	2.92	20	30	0.057	34.9	430			38.0	468			41.2	0.057	508	
		750	2.33	50	15	0.048	32.6	424			35.5	462			38.6	0.048	502	
		1000	1.75	50	20	0.038	30.6	414			33.3	451			36.2	0.038	489	
		1200	1.46	40	30	0.037	26.7	430			29.4	473			31.9	0.037	513	
		1500	1.17	50	30	0.033	23.9	430			26.3	472			28.5	0.033	513	
		1800	0.97	60	30	0.031	21.4	430			23.6	473			25.7	0.031	516	
		2000	0.88	50	40	0.026	21.7	406			23.9	448			26.0	0.026	486	
		2400	0.73	60	40	0.024	19.5	406			21.4	447			23.4	0.024	487	
3000	0.58	60	50	0.019	16.5	330			18.1	363			19.8	0.019	396			
3600	0.49	60	60	0.014	14.2	266			15.7	295			17.1	0.014	321			
SERIES 1800 RATINGS*	1750	50	35.0	5	10	0.713	65.3	838	ALL	ALL	69.8	896	ALL	ALL	74.7	0.713	959	
		75	23.3	5	15	0.531	60.1	862	RATIOS	RATIOS	64.3	922	RATIOS	RATIOS	69.2	0.531	992	
		100	17.5	5	20	0.427	57.4	883	THERMAL	THERMAL	61.5	946	THERMAL	THERMAL	66.0	0.427	1016	
		150	11.7	10	15	0.317	53.0	908	EQUALS	EQUALS	57.1	978	EQUALS	EQUALS	61.6	0.317	1056	
		200	8.75	10	20	0.253	50.8	927	MECH.	MECH.	54.6	997	MECH.	MECH.	59.0	0.253	1076	
		250	7.00	5	50	0.232	39.2	819			42.5	888			45.6	0.232	954	
		300	5.83	20	15	0.186	46.3	930			49.8	1001			54.1	0.186	1087	
		400	4.38	20	20	0.148	44.3	947			47.8	1021			51.9	0.148	1108	
		500	3.50	50	10	0.136	37.0	904			40.3	983			43.5	0.136	1061	
		600	2.92	20	30	0.123	34.7	920			38.8	1028			42.1	0.123	1116	
		750	2.33	50	15	0.105	32.8	930			35.8	1013			38.7	0.105	1098	
		1000	1.75	50	20	0.085	31.0	947			33.7	1030			36.6	0.085	1119	
		1200	1.46	40	30	0.082	26.4	932			29.9	1055			32.4	0.082	1144	
		1500	1.17	50	30	0.073	23.6	935			26.7	1057			29.0	0.073	1145	
		1800	0.97	60	30	0.068	21.2	937			24.0	1061			26.2	0.068	1157	
		2000	0.88	50	40	0.059	22.1	931			24.2	1023			26.4	0.059	1113	
		2400	0.73	60	40	0.055	19.7	931			21.8	1026			23.7	0.055	1119	
3000	0.58	60	50	0.045	16.8	819			18.5	903			20.1	0.045	983			
3600	0.49	60	60	0.035	14.5	659			16.0	727			17.5	0.035	794			
SERIES 2100 RATINGS	1750	50	35.0	5	10	1.11	65.5	1305	ALL	ALL	70.2	1397	ALL	ALL	74.9	1.11	1492	
		75	23.3	5	15	0.853	60.0	1381	RATIOS	RATIOS	64.2	1478	RATIOS	RATIOS	68.9	0.853	1588	
		100	17.5	5	20	0.610	57.4	1261	THERMAL	THERMAL	61.5	1349	THERMAL	THERMAL	66.1	0.610	1450	
		150	11.7	10	15	0.516	52.9	1475	EQUALS	EQUALS	57.0	1588	EQUALS	EQUALS	61.5	0.516	1715	
		200	8.75	10	20	0.349	50.5	1270	MECH.	MECH.	54.4	1368	MECH.	MECH.	58.7	0.349	1477	
		250	7.00	5	50	0.273	40.1	987			44.6	1097			48.0	0.273	1179	
		300	5.83	20	15	0.304	46.2	1519			49.7	1635			53.9	0.304	1774	
		400	4.38	20	20	0.201	43.8	1270			47.2	1369			51.3	0.201	1487	
		500	3.50	50	10	0.217	36.8	1439			40.0	1566			43.2	0.217	1692	
		600	2.92	20	30	0.205	34.7	1537			37.8	1674			41.0	0.205	1818	
		750	2.33	50	15	0.174	32.3	1519			35.0	1650			38.1	0.174	1793	
		1000	1.75	50	20	0.116	30.5	1270			33.2	1383			36.0	0.116	1500	
		1200	1.46	40	30	0.136	26.1	1537			28.8	1692			31.3	0.136	1838	
		1500	1.17	50	30	0.122	23.4	1537			25.7	1688			27.9	0.122	1833	
		1800	0.97	60	30	0.114	20.9	1537			23.0	1694			25.1	0.114	1848	
		2000	0.88	50	40	0.092	21.6	1424			23.7	1566			25.7	0.092	1698	
		2400	0.73	60	40	0.086	19.2	1424			21.2	1572			23.1	0.086	1712	
3000	0.58	60	50	0.054	17.1	987			19.3	1118			21.1	0.054	1219			
3600	0.49	60	60	0.048	14.3	896			15.8	989			17.3	0.048	1080			

ADDITIONAL RATINGS FOR OTHER INPUT SPEEDS ARE AVAILABLE AT: WWW.HUBCITYINC.COM

*OVERHUNG LOAD - LOW SPEED SHAFT – MODELS 1301 AND 1304 225 LBS. AT CENTER POINT OF SHAFT EXTENSION. MODELS 1801 AND 1804 550 LBS. AT CENTER POINT OF SHAFT EXTENSION. MODELS 1802, AND 1805 NOT APPLICABLE. THRUST‡ UP OR DOWN 600 LBS.

*OVERHUNG LOAD - LOW SPEED SHAFT – MODELS 2101 AND 2104 550 LBS. AT CENTER POINT OF SHAFT EXTENSION. MODELS 2102 AND 2105 NOT APPLICABLE. THRUST‡ UP OR DOWN 600 LBS.

‡OHL AND THRUST VALUES SHOWN ARE INDEPENDENT FUNCTIONS AND CANNOT BE APPLIED SIMULTANEOUSLY. REFER APPLICATIONS WITH COMBINED OHL AND THRUST TO HUB CITY CUSTOMER SERVICE DEPARTMENT.



UNIVERSAL POWER CUBE CATALOG RATINGS

SERIES 2400, 2600 & 3200

				RATIO COMB.		CONVENTIONAL OIL						PAO SYNTHETIC OIL				PAG SYNTHETIC OIL		
	INPUT RPM	RATIO	OUTPUT RPM	PRIM. RATIO	SEC. RATIO	MECH. INPUT HP	EFF. %	MECH. OUTPUT TORQUE	THERMAL INPUT HP	THERMAL OUTPUT TORQUE	EFF. %	MECH. OUTPUT TORQUE	THERMAL INPUT HP	THERMAL OUTPUT TORQUE	EFF. %	INPUT HP	OUTPUT TORQUE	
SERIES 2400 RATINGS*	1750	50	35.0	5	10	1.32	69.8	1663	ALL	ALL	74.6	1779	ALL	ALL	79.7	1.32	1900	
		75	23.3	5	15	0.992	65.8	1762	RATIOS	RATIOS	70.3	1884	RATIOS	RATIOS	75.6	0.992	2024	
		100	17.5	5	20	0.792	62.6	1784	THERMAL	THERMAL	66.9	1908	THERMAL	THERMAL	71.9	0.792	2050	
		150	11.7	10	15	0.574	59.4	1844	EQUALS	EQUALS	64.0	1985	EQUALS	EQUALS	69.0	0.574	2142	
		200	8.75	10	20	0.462	56.1	1865	MECH.	MECH.	60.3	2007	MECH.	MECH.	65.1	0.462	2165	
		250	7.00	5	50	0.381	51.1	1755			51.6	1773			55.3	0.381	1901	
		300	5.83	20	15	0.331	52.7	1886			56.7	2032			57.2	0.331	2047	
		400	4.38	20	20	0.267	49.6	1905			53.2	2045			57.7	0.267	2219	
		500	3.50	50	10	0.241	41.2	1784			44.7	1939			48.3	0.241	2095	
		600	2.92	20	30	0.205	43.1	1909			46.9	2077			50.8	0.205	2252	
		750	2.33	50	15	0.185	37.8	1886			41.1	2053			44.6	0.185	2226	
		1000	1.75	50	20	0.151	35.1	1905			38.2	2070			41.5	0.151	2248	
		1200	1.46	40	30	0.132	33.4	1909			36.7	2098			39.8	0.132	2274	
		1500	1.17	50	30	0.118	30.0	1909			33.0	2098			35.8	0.118	2277	
		1800	0.97	60	30	0.109	27.0	1909			29.8	2105			32.4	0.109	2294	
		2000	0.88	50	40	0.098	26.6	1873			29.3	2058			31.8	0.098	2236	
2400	0.73	60	40	0.091	23.9	1873			26.4	2065			28.7	0.091	2249			
3000	0.58	60	50	0.082	21.3	1887			24.1	2136			26.2	0.082	2325			
3600	0.49	60	60	0.053	21.8	1487			23.3	1588			25.5	0.053	1738			
SERIES 2600 RATINGS	1750	50	35.0	5	10	1.40	68.9	1737	1.29	1601	74.2	1870	ALL	ALL	78.8	1.40	1987	
		75	23.3	5	15	1.40	62.4	2359	1.29	2174	66.8	2524	RATIOS	RATIOS	71.7	1.40	2711	
		100	17.5	5	20	1.29	61.3	2840	1.29	2840	65.6	3040	THERMAL	THERMAL	70.4	1.29	3264	
		150	11.7	10	15	0.910	55.3	2717	0.820	2448	59.4	2921	EQUALS	EQUALS	64.2	0.91	3157	
		200	8.75	10	20	0.774	54.4	3030	0.774	3030	58.5	3259	MECH.	MECH.	63.2	0.774	3520	
		250	7.00	5	50	0.440	47.6	1887	0.440	1887	51.5	2041			55.3	0.440	2193	
		300	5.83	20	15	0.550	48.3	2869	0.550	2869	52.0	3092			56.4	0.550	3354	
		400	4.38	20	20	0.455	47.6	3119	0.455	3119	51.3	3358			55.6	0.455	3644	
		500	3.50	50	10	0.270	38.2	1856	0.270	1856	43.4	2108			46.9	0.270	2278	
		600	2.92	20	30	0.415	37.2	3338	0.415	3338	40.5	3630			43.9	0.415	3939	
		750	2.33	50	15	0.270	33.8	2468	0.270	2468	36.8	2685			40.0	0.270	2915	
		1000	1.75	50	20	0.259	33.4	3119	0.259	3119	36.3	3395			39.4	0.259	3683	
		1200	1.46	40	30	0.275	28.1	3338	0.275	3338	30.9	3669			33.5	0.275	3982	
		1500	1.17	50	30	0.246	25.1	3338	0.246	3338	27.6	3671			30.0	0.246	3982	
		1800	0.97	60	30	0.229	22.5	3338	0.229	3338	24.7	3675			27.0	0.229	4013	
		2000	0.88	50	40	0.159	24.6	2823	0.159	2823	27.0	3101			29.3	0.159	3366	
2400	0.73	60	40	0.148	22.0	2823	0.148	2823	24.2	3111			26.4	0.148	3393			
3000	0.58	60	50	0.082	21.3	1887	0.082	1887	23.5	2083			25.6	0.082	2270			
3600	0.49	60	60	0.109	14.9	2102	0.109	2102	16.5	2330			18.0	0.109	2542			
SERIES 3200 RATINGS**	1750	50	35.0	5	10	3.77	69.3	4708	2.80	3496	74.3	5042	3.32	4440	79.4	3.77	5388	
		75	23.3	5	15	3.22	65.0	5661	2.80	4918	69.6	6062	3.22	6062	74.8	3.22	6510	
		100	17.5	5	20	2.46	61.6	5465	2.46	5465	65.9	5848	2.46	5848	70.8	2.46	6278	
		150	11.7	10	15	2.00	58.2	6284	1.74	5468	62.7	6768	2.00	6768	67.7	2.00	7311	
		200	8.75	10	20	1.42	54.5	5591	1.42	5591	58.8	6028	1.42	6028	63.4	1.42	6501	
		250	7.00	5	50	1.05	45.4	4273	1.05	4273	49.0	4614	1.05	4614	52.7	1.05	4959	
		300	5.83	20	15	1.18	51.5	6551	1.14	6339	55.4	7052	1.18	7052	60.1	1.18	7650	
		400	4.38	20	20	0.811	47.9	5591	0.811	5591	51.6	6026	0.811	6026	56.0	0.811	6537	
		500	3.50	50	10	0.842	42.3	6418	0.842	6418	46.1	6985	0.842	6985	49.7	0.842	7543	
		600	2.92	20	30	0.792	38.7	6627	0.792	6627	43.9	7515	0.792	7515	47.7	0.792	8153	
		750	2.33	50	15	0.634	38.3	6551	0.634	6551	41.6	7125	0.634	7125	45.2	0.634	7734	
		1000	1.75	50	20	0.443	35.1	5591	0.443	5591	38.2	6100	0.443	6100	41.5	0.443	6624	
		1200	1.46	40	30	0.494	31.1	6627	0.494	6627	34.2	7302	0.494	7302	37.1	0.494	7920	
		1500	1.17	50	30	0.425	28.8	6627	0.425	6627	31.7	7291	0.425	7291	34.5	0.425	7921	
		1800	0.97	60	30	0.409	25.0	6627	0.409	6627	28.2	7494	0.409	7494	30.7	0.409	8141	
		2000	0.88	50	40	0.304	25.5	5584	0.304	5584	28.0	6139	0.304	6139	30.4	0.304	6662	
2400	0.73	60	40	0.287	22.5	5584	0.287	5584	24.8	6155	0.287	6155	27.0	0.287	6698			
3000	0.58	60	50	0.197	20.0	4273	0.197	4273	22.1	4712	0.197	4712	24.1	0.197	5139			
3600	0.49	60	60	0.145	18.0	3369	0.145	3369	19.8	3714	0.145	3714	21.7	0.145	4069			

ADDITIONAL RATINGS FOR OTHER INPUT SPEEDS ARE AVAILABLE AT: WWW.HUBCITYINC.COM

**OVERHUNG LOAD - LOW SPEED SHAFT — MODELS 2401 AND 2404 1150 LBS. AT CENTER POINT OF SHAFT EXTENSION. MODELS 2402 AND 2405 NOT APPLICABLE.

THRUST‡ UP OR DOWN 1000 LBS.

MODELS 2601 AND 2604 1150 LBS. AT CENTER POINT OF SHAFT EXTENSION. MODELS 2602 AND 2605 NOT APPLICABLE.

THRUST‡ UP OR DOWN 1000 LBS.

MODELS 3201 AND 3204 1,100 LBS. AT CENTER POINT OF SHAFT EXTENSION. MODELS 3202 AND 3205 NOT APPLICABLE.

MODELS 3207 AND 3208 — OHL* 1,280 LBS., TO* THRUST OUT 1,700 LBS. AND † THRUST IN 1,210 LBS. THRUST‡ UP OR DOWN 1,200 LBS.

‡OHL AND THRUST VALUES SHOWN ARE INDEPENDENT FUNCTIONS AND CANNOT BE APPLIED SIMULTANEOUSLY. REFER APPLICATIONS WITH COMBINED OHL AND THRUST TO HUB CITY CUSTOMER SERVICE DEPARTMENT.



UNIVERSAL POWER CUBE CATALOG RATINGS

SERIES 3800, 4500 & 5200				RATIO COMB.		CONVENTIONAL OIL					PAO SYNTHETIC OIL				PAG SYNTHETIC OIL		
	INPUT RPM	RATIO	OUTPUT RPM	PRIM. RATIO	SEC. RATIO	MECH. INPUT HP	EFF.	MECH.	THERMAL	THERMAL	EFF.	MECH.	THERMAL	THERMAL	EFF.	INPUT	OUTPUT
							%	OUTPUT TORQUE	INPUT HP	OUTPUT TORQUE	%	OUTPUT TORQUE	INPUT HP	OUTPUT TORQUE	%	HP	TORQUE
SERIES 3800 RATINGS	1750	50	35.0	5	10	3.77	70.7	4797	2.80	3563	75.5	5129	3.32	4516	80.8	3.77	5484
		75	23.3	5	15	3.77	66.4	6766	2.80	5025	71.3	7258	3.32	6392	76.4	3.77	7778
		100	17.5	5	20	3.31	64.0	7630	2.80	6451	68.4	8154	3.31	8154	73.5	3.31	8763
		150	11.7	10	15	2.86	59.0	9110	1.74	5546	63.4	9794	2.86	9794	68.8	2.86	10629
		200	8.75	10	20	1.87	56.8	7656	1.74	7113	61.1	8242	1.87	8242	65.9	1.87	8888
		250	7.00	5	50	1.33	48.9	5866	1.33	5866	53.0	6357	1.33	6357	56.9	1.33	6823
		300	5.83	20	15	1.66	52.5	9412	1.14	6471	56.4	10096	1.66	10096	61.3	1.66	10975
		400	4.38	20	20	1.07	49.7	7656	1.07	7656	53.5	8240	1.07	8240	58.4	1.07	9003
		500	3.50	50	10	1.14	43.5	8904	1.14	8904	47.5	9721	1.14	9721	51.2	1.14	9574
		600	2.92	20	30	1.10	40.1	9524	1.10	9524	45.8	10858	1.10	10858	49.3	1.10	11701
		750	2.33	50	15	0.750	39.1	7924	0.630	6656	42.5	8611	0.750	8611	47.0	0.750	9516
		1000	1.75	50	20	0.572	37.1	7656	0.572	7656	40.4	8322	0.572	8322	43.8	0.572	9030
		1200	1.46	40	30	0.706	31.2	9524	0.706	9524	35.9	10951	0.706	10951	38.8	0.706	11834
		1500	1.17	50	30	0.425	28.8	6627	0.425	6627	31.7	7291	0.425	7291	34.5	0.425	7921
		1800	0.97	60	30	0.561	26.2	9524	0.561	9524	29.7	10811	0.561	10811	32.1	0.561	11698
2000	0.88	50	40	0.385	27.7	7684	0.385	7684	30.6	8489	0.385	8489	33.1	0.385	9180		
2400	0.73	60	40	0.363	24.5	7684	0.363	7684	27.1	8493	0.363	8493	29.4	0.363	9231		
3000	0.58	60	50	0.244	22.3	5866	0.244	5866	24.5	6454	0.244	6454	26.8	0.244	7058		
3600	0.49	60	60	0.178	20.4	4702	0.178	4702	22.4	5181	0.178	5181	24.6	0.178	5675		
SERIES 4500 RATINGS*	1750	50	35.0	5	10	8.96	72.9	11750	6.99	9170	78.0	12579	8.27	11615	83.4	8.96	13450
		75	23.3	5	15	6.71	68.8	12480	6.71	12480	73.7	13356	6.71	13356	79.1	6.71	14345
		100	17.5	5	20	5.25	66.5	12580	5.25	12580	71.3	13480	5.25	13480	76.5	5.25	14480
		150	11.7	10	15	4.14	62.6	13980	3.99	13487	67.4	15058	4.14	15058	72.8	4.14	16258
		200	8.75	10	20	2.98	60.2	12920	2.98	60.2	64.8	13918	2.98	13918	69.9	2.98	15012
		250	7.00	5	50	2.12	52.0	9919	2.12	52.0	56.3	10740	2.12	10740	60.5	2.12	11531
		300	5.83	20	15	2.42	56.2	14700	2.42	56.2	60.5	15838	2.42	15838	65.7	2.42	17185
		400	4.38	20	20	1.67	53.8	12920	1.67	53.8	57.9	13923	1.67	13923	62.9	1.67	15113
		500	3.50	50	10	1.62	47.8	13900	1.62	47.8	52.1	15139	1.62	15139	56.2	1.62	9574
		600	2.92	20	30	1.52	45.4	14876	1.52	45.4	49.5	16223	1.52	16223	53.4	1.52	17502
		750	2.33	50	15	1.25	43.4	14700	1.25	43.4	47.3	16021	1.25	16021	51.3	1.25	17376
		1000	1.75	50	20	0.87	41.2	12920	0.87	41.2	45.0	14087	0.87	14087	48.8	0.87	15287
		1200	1.46	40	30	0.95	36.4	14876	0.95	36.4	40.0	16379	0.95	16379	43.3	0.95	17697
		1500	1.17	50	30	0.81	33.8	14876	0.81	33.8	37.3	16412	0.81	16412	40.5	0.81	17797
		1800	0.97	60	30	0.73	31.4	14876	0.73	31.4	34.6	16390	0.73	16390	37.8	0.73	17880
2000	0.88	50	40	0.58	31.2	13008	0.58	31.2	34.4	14322	0.58	14322	37.3	0.58	15522		
2400	0.73	60	40	0.52	28.9	13006	0.52	28.9	31.9	14330	0.52	14330	34.7	0.52	15625		
3000	0.58	60	50	0.35	26.5	9919	0.35	26.5	29.1	10902	0.35	10902	31.8	0.35	11906		
3600	0.49	60	60	0.25	24.2	7915	0.25	24.2	26.7	8715	0.25	8715	29.2	0.25	9553		
SERIES 5200 RATINGS	1750	50	35.0	5	10	12.79	73.8	17000	6.99	9294	79.0	18191	8.27	11766	84.4	12.79	19442
		75	23.3	5	15	9.55	70.2	18100	6.99	13248	75.1	19381	8.27	16783	80.7	9.55	20824
		100	17.5	5	20	7.28	68.3	17910	6.99	17191	73.0	19148	7.28	19148	78.4	7.28	20574
		150	11.7	10	15	5.89	64.2	20415	3.99	13838	69.1	21969	4.69	17504	74.5	5.89	23697
		200	8.75	10	20	4.21	62.1	18820	3.99	17836	66.7	20224	4.21	20224	71.9	4.21	21789
		250	7.00	5	50	2.97	54.5	14590	2.97	14590	59.1	15812	2.97	15812	63.4	2.97	16972
		300	5.83	20	15	3.45	57.8	21510	2.49	15541	62.2	23151	2.93	19682	67.6	3.45	25158
		400	4.38	20	20	2.37	55.6	19020	2.37	19020	59.6	20386	2.37	20386	64.5	2.37	22074
		500	3.50	50	10	2.31	48.9	20330	1.23	10821	53.2	22153	1.43	13709	57.4	2.31	9574
		600	2.92	20	30	2.12	47.6	21780	2.12	21780	51.5	23546	2.12	23546	55.6	2.12	25409
		750	2.33	50	15	1.77	44.9	21510	1.23	14912	48.9	23415	1.43	18872	53.0	1.77	25398
		1000	1.75	50	20	1.23	42.9	19020	1.23	19020	46.7	20708	1.23	20708	50.6	1.23	22438
		1200	1.46	40	30	1.32	38.3	21780	1.32	21780	42.0	23881	1.32	23881	45.5	1.32	25846
		1500	1.17	50	30	1.13	35.7	21780	1.13	21780	39.2	23926	1.13	23926	42.4	1.13	25897
		1800	0.97	60	30	1.01	33.2	21780	1.01	21780	36.5	23937	1.01	23937	39.7	1.01	26060
2000	0.88	50	40	0.82	32.6	19260	0.82	19260	35.9	21206	0.82	21206	38.9	0.82	22990		
2400	0.73	60	40	0.72	30.7	19260	0.72	19260	33.8	21161	0.72	21161	36.8	0.72	23064		
3000	0.58	60	50	0.48	28.3	14590	0.48	14590	31.1	16024	0.48	16024	33.9	0.48	17490		
3600	0.49	60	60	0.34	26.2	11580	0.34	11580	28.7	12706	0.34	12706	31.4	0.34	13914		

ADDITIONAL RATINGS FOR OTHER INPUT SPEEDS ARE AVAILABLE AT: WWW.HUBCITYINC.COM

*OVERHUNG LOAD - LOW SPEED SHAFT – MODELS 3801 AND 3804 1,600 LBS. AT CENTER POINT OF SHAFT EXTENSION. MODELS 3802 AND 3805 NOT APPLICABLE. MODELS 3807 AND 3808 – OHL † 1,970 LBS., TO† THRUST OUT 1,950 LBS. AND TI† THRUST IN 1,500 LBS. THRUST‡ UP OR DOWN 1,500 LBS.

*OVERHUNG LOAD - LOW SPEED SHAFT – MODELS 4501 AND 4504 2,200 LBS. AT CENTER POINT OF SHAFT EXTENSION. MODELS 4502, 4503, 4505, AND 4506 NOT APPLICABLE. MODELS 4507 AND 4508 – OHL † 2,370 LBS., TO† THRUST OUT 3,330 LBS. AND TI† THRUST IN 3,140 LBS. MODELS 4509 AND 4510 2,000 LBS. AT CENTER POINT OF SHAFT EXTENSION. THRUST‡ UP OR DOWN 2,500 LBS.

OVERHUNG LOAD - LOW SPEED SHAFT – MODELS 5201 AND 5204 2,600 LBS. AT CENTER POINT OF SHAFT EXTENSION. MODELS 5202, 5203, 5205, AND 5206 NOT APPLICABLE. MODELS 5207 AND 5208 – OHL † 3,550 LBS., TO† THRUST OUT 4,530 LBS. AND TI† THRUST IN 3,360 LBS. MODELS 5209 AND 5210 2,300 LBS. AT CENTER POINT OF SHAFT EXTENSION. THRUST‡ UP OR DOWN 3,000 LBS.

†OHL AND THRUST VALUES SHOWN ARE INDEPENDENT FUNCTIONS AND CANNOT BE APPLIED SIMULTANEOUSLY. REFER APPLICATIONS WITH COMBINED OHL AND THRUST TO HUB CITY CUSTOMER SERVICE DEPARTMENT.

B

DOUBLE REDUCTION



GW SERIES CATALOG RATINGS

SERIES GW60D & GW70D

					CONVENTIONAL OIL		PAO SYNTHETIC OIL		PAG SYNTHETIC OIL	
	INPUT RPM	RATIO	OUTPUT RPM	MECH. INPUT HP	EFF. %	MECH. OUTPUT TORQUE	EFF. %	MECH. OUTPUT TORQUE	EFF. %	MECH. OUTPUT TORQUE
SERIES GW60D RATINGS	1750	75	23.1	9.10	78.4	19271	80.4	19753	81.9	20138
		100	16.5	8.67	68.6	21417	70.3	21952	71.7	22381
		150	11.4	5.95	73.3	23471	75.1	24058	76.6	24527
		200	8.54	4.95	69.0	24607	70.7	25222	72.1	25714
		250	7.14	4.25	64.9	24841	66.5	25462	67.8	25959
		300	5.69	3.61	65.9	25821	67.5	26467	68.8	26983
		400	4.27	3.01	61.4	26473	63.0	27135	64.2	27664
		500	3.41	2.52	59.3	26872	60.8	27544	62.0	28081
		600	2.85	2.24	55.7	27151	57.1	27830	58.2	28373
		750	2.38	1.93	51.8	27386	53.1	28071	54.1	28618
		900	1.98	1.62	51.0	27434	52.3	28120	53.3	28669
		1000	1.75	1.61	49.2	27737	50.4	28430	51.4	28985
		1200	1.42	1.40	47.0	27683	48.1	28375	49.1	28929
		1500	1.19	1.24	43.1	28088	44.2	28790	45.1	29352
		1800	0.99	1.00	40.1	25273	41.1	25905	41.9	26410
2400	0.73	0.84	36.9	27893	37.9	28590	38.6	29148		
3000	0.58	0.75	34.0	26792	34.9	27462	35.5	27998		
3600	0.49	0.65	28.0	23067	28.7	23644	29.3	24105		
SERIES GW70D RATINGS	1750	75	23.1	9.13	82.7	20601	84.8	21116	86.4	21528
		100	16.5	9.13	79.1	27535	81.1	28223	82.6	28774
		150	11.4	7.25	76.3	30621	78.2	31387	79.7	31999
		200	8.54	5.81	74.4	31857	76.2	32653	77.7	33291
		250	7.14	4.90	72.2	31238	74.1	32019	75.5	32644
		300	5.69	4.27	70.0	33136	71.8	33964	73.2	34627
		400	4.27	3.41	67.2	33805	68.8	34650	70.2	35326
		500	3.41	2.86	64.7	34209	66.3	35064	67.6	35748
		600	2.85	2.53	61.7	34477	63.2	35339	64.4	36028
		750	2.38	2.13	59.6	33682	61.1	34524	62.3	35198
		900	1.98	1.73	58.4	32016	59.8	32816	61.0	33457
		1000	1.75	1.73	54.9	35031	56.2	35907	57.3	36607
		1200	1.42	1.52	52.2	35168	53.5	36047	54.6	36751
		1500	1.19	1.28	50.6	34325	51.9	35183	52.9	35870
		1800	0.99	1.04	49.1	32580	50.4	33395	51.3	34046
2400	0.73	0.90	43.3	33661	44.4	34503	45.2	35176		
3000	0.58	0.76	39.7	32512	40.7	33325	41.5	33975		
3600	0.49	0.60	37.8	29307	38.7	30040	39.5	30626		

NOTE: ALL TORQUE VALUES LISTED IN INCH-POUNDS, ALL OVERHUNG LOAD VALUES LISTED IN POUNDS. THE POINT OF APPLICATION OF THE OVERHUNG LOAD IS CONSIDERED TO BE ONE SHAFT DIAMETER MEASURED OUTWARD FROM THE GEAR CASE HOUSING. AT SPEEDS ABOVE 1750 RPM, UNITS MAY BECOME THERMALLY LIMITED. FOR EXTENDED OPERATION, LIMIT INPUT HP TO 1750 RPM CATALOG RATING.

THRUST AND OVERHUNG LOAD RATINGS (LBS.)	GW60D	GW70D
Thrust Load Ratings (Low Speed Shaft, All Ratios)	3990	4009
Overhung Load Capacity* (High Speed Shaft, All Ratios)	150	150
Overhung Load Capacity* (Low Speed Shaft, All Ratios)	3723	6209
Overhung Load Capacity** (Extended Brg Design Output Shaft, All Ratios)	2245	3791

ADDITIONAL RATINGS FOR OTHER INPUT SPEEDS ARE AVAILABLE AT: WWW.HUBCITYINC.COM

*OHL AND THRUST VALUES SHOWN ARE INDEPENDENT FUNCTIONS AND CANNOT BE APPLIED SIMULTANEOUSLY. REFER APPLICATIONS WITH COMBINED OHL AND THRUST TO HUB CITY CUSTOMER SERVICE DEPARTMENT.

*THE POINT OF APPLICATION OF THE OVERHUNG LOAD IS CONSIDERED TO BE ONE SHAFT DIAMETER MEASURED OUTWARD FROM THE GEARCASE HOUSING.

**LOAD LOCATED AT END OF OUTPUT SHAFT.



GW SERIES CATALOG RATINGS

SERIES GW80D & GW100D

					CONVENTIONAL OIL		PAO SYNTHETIC OIL		PAG SYNTHETIC OIL	
	INPUT RPM	RATIO	OUTPUT RPM	MECH. INPUT HP	EFF. %	MECH. OUTPUT TORQUE	EFF. %	MECH. OUTPUT TORQUE	EFF. %	MECH. OUTPUT TORQUE
SERIES GW80D RATINGS	1750	75	23.1	15.50	83.9	35507	86.0	36395	87.6	37105
		100	16.5	12.60	80.2	38575	82.2	39539	83.8	40311
		150	11.4	9.82	77.6	42212	79.5	43267	81.1	44112
		200	8.54	7.92	75.5	44158	77.4	45262	78.9	46145
		250	7.14	6.61	73.8	43010	75.7	44085	77.1	44945
		300	5.69	5.82	71.6	46181	73.4	47336	74.9	48259
		400	4.27	4.65	68.8	47245	70.5	48426	71.9	49371
		500	3.41	3.88	67.0	45835	68.7	46981	70.0	47898
		600	2.85	3.43	63.6	48316	65.1	49524	66.4	50490
		750	2.38	2.87	61.7	46812	63.2	47982	64.4	48919
		900	1.98	2.50	58.8	46627	60.3	47793	61.4	48725
		1000	1.75	2.34	56.8	49201	58.3	50431	59.4	51415
		1200	1.42	2.05	54.6	49420	56.0	50656	57.1	51644
		1500	1.19	1.71	52.8	47819	54.1	49014	55.2	49971
		1800	0.99	1.29	52.2	42944	53.6	44018	54.6	44876
		2400	0.73	1.20	45.3	46987	46.5	48162	47.4	49101
3000	0.58	1.02	41.5	45708	42.5	46851	43.3	47765		
3600	0.49	0.80	39.6	41112	40.6	42140	41.4	42962		
SERIES GW100D RATINGS	1750	75	23.1	26.5	84.9	61010	87.0	62535	88.7	63755
		100	16.5	20.8	81.7	64363	83.8	65972	85.4	67259
		150	11.4	16.5	78.8	72069	80.8	73871	82.3	75312
		200	8.54	13.5	76.3	76261	78.2	78168	79.7	79693
		250	7.14	11.3	74.8	74571	76.6	76435	78.1	77927
		300	5.69	10.1	72.2	80671	74.0	82688	75.4	84301
		400	4.27	8.12	69.2	83011	70.9	85086	72.3	86746
		500	3.41	6.89	66.3	84431	68.0	86542	69.3	88230
		600	2.85	6.03	64.0	85377	65.6	87511	66.9	89219
		750	2.38	5.04	62.1	82964	63.7	85038	64.9	86697
		900	1.98	4.13	60.3	79353	61.8	81337	63.0	82924
		1000	1.75	4.21	56.3	87344	57.7	89528	58.8	91274
		1200	1.42	3.73	53.1	87832	54.4	90028	55.5	91784
		1500	1.19	3.13	51.4	85216	52.7	87346	53.8	89051
		1800	0.99	2.56	50.0	81353	51.3	83387	52.3	85014
		2400	0.73	2.17	44.4	83314	45.5	85397	46.4	87063
3000	0.58	1.83	42.6	80836	43.7	82857	44.5	84474		
3600	0.49	1.46	38.7	73284	39.7	75116	40.4	76582		

B

DOUBLE REDUCTION

NOTE: ALL TORQUE VALUES LISTED IN INCH-POUNDS, ALL OVERHUNG LOAD VALUES LISTED IN POUNDS. THE POINT OF APPLICATION OF THE OVERHUNG LOAD IS CONSIDERED TO BE ONE SHAFT DIAMETER MEASURED OUTWARD FROM THE GEAR CASE HOUSING. AT SPEEDS ABOVE 1750 RPM, UNITS MAY BECOME THERMALLY LIMITED. FOR EXTENDED OPERATION, LIMIT INPUT HP TO 1750 RPM CATALOG RATING.

THRUST AND OVERHUNG LOAD RATINGS (LBS.)	GW80D	GW100D
Thrust Load Ratings (Low Speed Shaft, All Ratios)	4777	6808
Overhung Load Capacity* (High Speed Shaft, All Ratios)	175	300
Overhung Load Capacity* (Low Speed Shaft, All Ratios)	7761	11028
Overhung Load Capacity** (Extended Brg Design Output Shaft, All Ratios)	4850	8500

ADDITIONAL RATINGS FOR OTHER INPUT SPEEDS ARE AVAILABLE AT: WWW.HUBCITYINC.COM

*OHL AND THRUST VALUES SHOWN ARE INDEPENDENT FUNCTIONS AND CANNOT BE APPLIED SIMULTANEOUSLY. REFER APPLICATIONS WITH COMBINED OHL AND THRUST TO HUB CITY CUSTOMER SERVICE DEPARTMENT.

**THE POINT OF APPLICATION OF THE OVERHUNG LOAD IS CONSIDERED TO BE ONE SHAFT DIAMETER MEASURED OUTWARD FROM THE GEARCASE HOUSING.

**LOAD LOCATED AT END OF OUTPUT SHAFT.



MODELS

1301, 1801, 2101, 2401, 2601, 3201, 3801, 4501, 5201, GW6001, GW7001, GW8001, GW10001

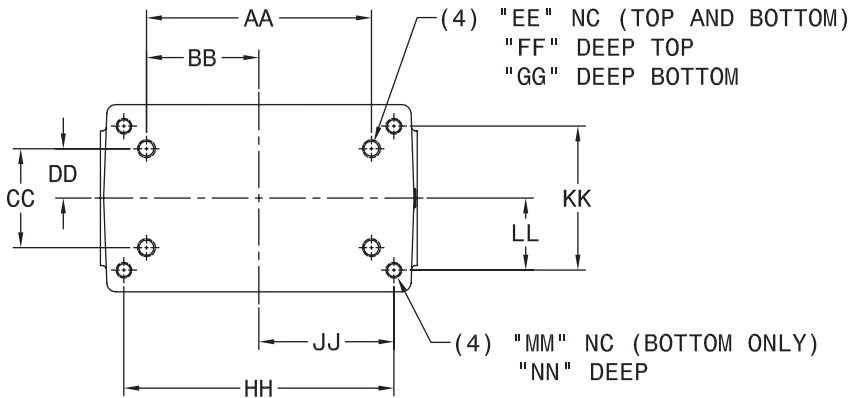
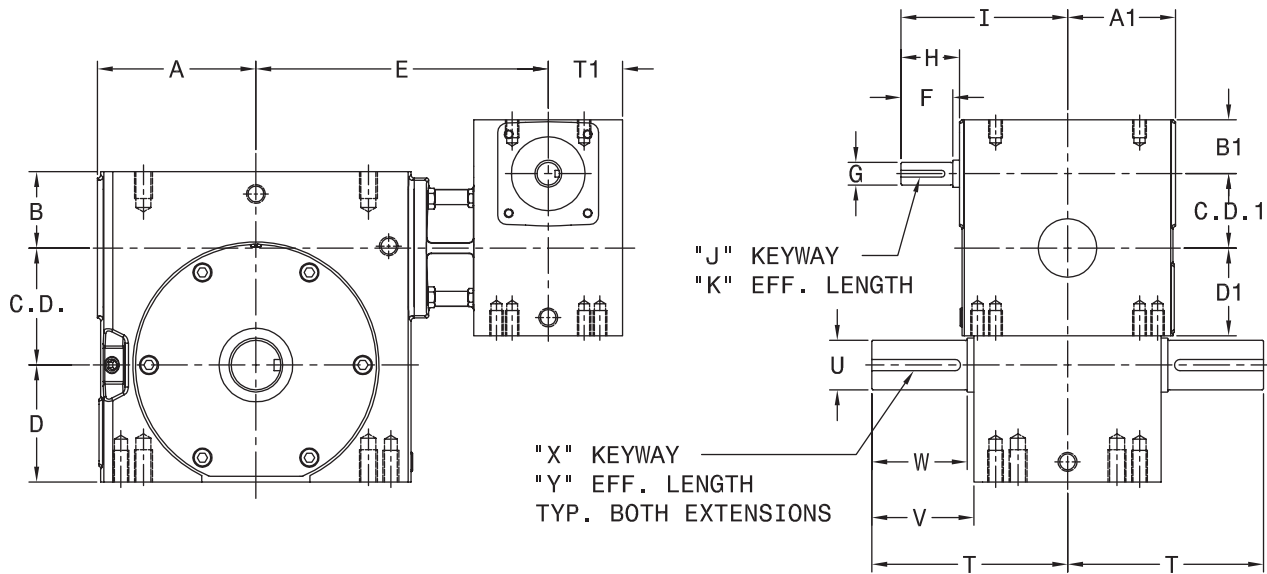

FOR LUBRICATION AND INSTALLATION INSTRUCTIONS REFER TO SECTION R.

STANDARD STYLES AVAILABLE

DIMENSIONS SHOWN ARE FOR REFERENCE ONLY.
DOWNLOAD AVAILABLE CAD MODELS AT:
WWW.HUBCITYINC.COM

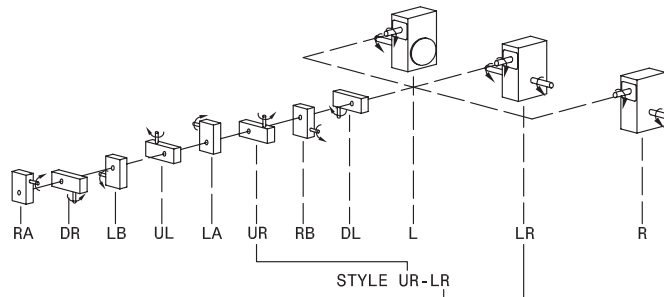

CONSULT FACTORY FOR VERTICAL SHAFT LUBRICATION RECOMMENDATIONS
INPUT SHAFT CAN BE ROTATED IN EITHER DIRECTION



MODELS

1301, 1801, 2101, 2401, 2601, 3201, 3801, 4501, 5201, GW6001, GW7001, GW8001, GW10001

B

MODEL	PRIMARY	SECONDARY	C.D.	C.D.1	A	A1	B	B1	D	D1	E	F
1301	131	134-56C	1.334	1.334	2.28	2.28	1.186	1.186	1.562	1.562	5.07	1.35
1801	131	184-56C	1.751	1.334	2.65	2.28	1.374	1.186	1.875	1.562	5.44	1.35
2101	131	214-56C	2.064	1.334	3.00	2.28	1.500	1.186	2.437	1.562	5.87	1.35
2401	131	244-56C	2.376	1.334	3.38	2.28	2.062	1.186	2.500	1.562	6.25	1.35
2601	131	264-56C	2.626	1.334	3.66	2.28	1.874	1.186	2.938	1.562	6.53	1.35
3201	211	324-143TC	3.251	2.064	4.40	3.00	2.124	1.500	3.250	2.437	8.12	1.44
3801	211	384-143TC	3.751	2.064	4.90	3.00	2.374	1.500	3.937	2.437	8.62	1.44
4501	321	454-213TC	4.501	3.251	5.67	4.40	2.499	2.124	4.625	3.250	9.13	2.23
5201	321	524-213TC	5.168	3.251	6.42	4.40	2.624	2.124	5.375	3.250	9.88	2.23
GW6001	CUSTOM	GW601	6.000	3.251	10.24	5.02	4.00	2.63	6.50	3.50	13.30	2.35
GW7001	CUSTOM	GW701	7.000	3.251	10.63	5.02	4.32	2.63	7.59	3.50	12.96	2.35
GW8001	CUSTOM	GW801	8.000	4.251	11.93	6.10	4.10	2.69	8.86	4.44	13.94	3.57
GW10001	CUSTOM	GW1001	10.000	5.251	14.34	7.50	5.11	3.63	10.36	5.12	17.05	3.40

MODEL	G	H	I	J	K	T	T1	U	V	W	X	Y
1301	.500/.499	1.54	3.82	1/8 X 1/16	1.16	3.25	1.56	.625/.624	1.69	N/A	3/16 X 3/32	1.38
1801	.500/.499	1.54	3.82	1/8 X 1/16	1.16	3.50	1.56	.750/.749	1.78	1.54	3/16 X 3/32	1.41
2101	.500/.499	1.54	3.82	1/8 X 1/16	1.16	4.25	1.56	.875/.874	2.19	1.95	3/16 X 3/32	1.83
2401	.500/.499	1.54	3.82	1/8 X 1/16	1.16	4.50	1.56	1.125/1.124	2.31	2.06	1/4 X 1/8	1.74
2601	.500/.499	1.54	3.82	1/8 X 1/16	1.16	4.50	1.56	1.250/1.249	2.25	N/A	1/4 X 1/8	1.85
3201	.625/.624	1.63	4.63	3/16 X 3/32	1.13	5.44	2.06	1.375/1.374	2.84	N/A	5/16 X 5/32	2.31
3801	.625/.624	1.63	4.63	3/16 X 3/32	1.13	6.69	2.06	1.500/1.499	3.88	N/A	3/8 X 3/16	3.16
4501	.875/.874	2.48	6.88	3/16 X 3/32	1.91	7.25	2.60	1.625/1.624	4.18	3.90	3/8 X 3/16	3.28
5201	.875/.874	2.48	6.88	3/16 X 3/32	1.91	7.81	2.60	1.750/1.749	4.47	4.17	3/8 X 3/16	3.50
GW6001	0.875	2.38	6.76	3/16 X 3/32	1.75	10.00	3.40	2.500	4.65	N/A	5/8 X 5/16	4.00
GW7001	0.875	2.38	6.76	3/16 X 3/32	1.75	11.76	3.40	2.750	5.65	N/A	5/8 X 5/16	4.00
GW8001	1.250	3.47	9.57	1/4 X 1/8	2.88	12.25	3.62	3.000	5.98	5.26	3/4 X 3/8	4.50
GW10001	1.250	3.38	10.88	1/4 X 1/8	3.00	14.75	4.28	3.750	6.76	N/A	7/8 X 7/16	5.00

DOUBLE REDUCTION

MODEL	AA	BB	CC	DD	EE	FF	GG	HH	JJ	KK	LL	MM	NN	WT. LBS.
1301	2.250	1.125	1.625	.812	1/4 UNC	.50	.50	3.250	1.625	2.000	1.000	5/16 NC	.75	20
1801	3.125	1.562	1.625	.812	1/4 UNC	.50	.50	4.188	2.094	2.750	1.375	5/16 NC	.75	25
2101	4.000	2.000	2.000	1.000	3/8 UNC	.50	.70	5.000	2.500	2.875	1.438	3/8 NC	.70	34
2401	5.000	2.500	2.875	1.438	3/8 UNC	.70	.70	N/A	N/A	N/A	N/A	N/A	N/A	42
2601	4.875	2.437	2.688	1.344	3/8 UNC	.70	.70	6.375	3.188	3.375	1.688	3/8 NC	.70	47
3201	6.250	3.125	2.750	1.375	1/2 UNC	.75	.90	7.500	3.750	4.000	2.000	7/16 NC	.88	83
3801	6.875	3.438	3.000	1.500	1/2 UNC	.94	1.00	8.500	4.250	4.750	2.375	1/2 NC	1.00	108
4501	8.125	4.063	3.250	1.625	5/8 UNC	.88	1.13	N/A	N/A	N/A	N/A	N/A	N/A	172
5201	9.500	4.750	3.750	1.875	5/8 UNC	1.00	1.25	N/A	N/A	N/A	N/A	N/A	N/A	198
GW6001	12.750	6.380	6.380	3.190	5/8 UNC	1.00	1.00	N/A	N/A	N/A	N/A	N/A	N/A	402
GW7001	12.500	6.250	5.500	2.750	1 UNC	1.56	1.56	N/A	N/A	N/A	N/A	N/A	N/A	478
GW8001	14.250	7.125	6.500	3.250	1 UNC	1.66	1.66	N/A	N/A	N/A	N/A	N/A	N/A	718
GW10001	17.750	8.875	6.875	3.438	1-1/4 UNC	2.04	2.04	N/A	N/A	N/A	N/A	N/A	N/A	1136



MODELS

1802, 2102, 2402, 2602, 3202, 3802, 4502, 5202, GW6002, GW7002, GW8002, GW10002

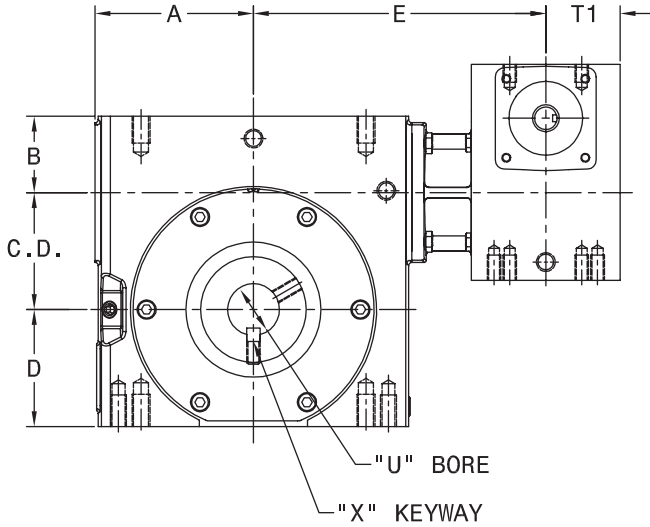

QD BUSHING DETAIL FOR MODELS 4502 & 5202

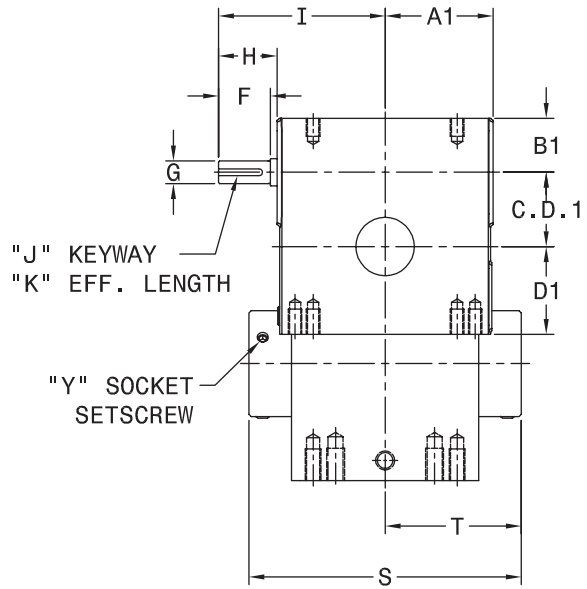

FOR LUBRICATION AND INSTALLATION INSTRUCTIONS REFER TO SECTION R.

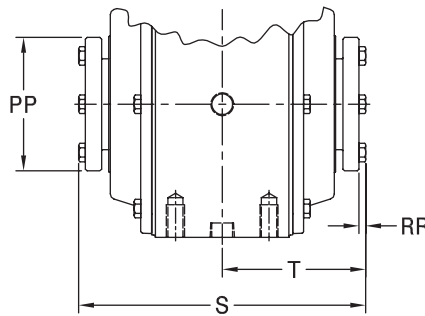
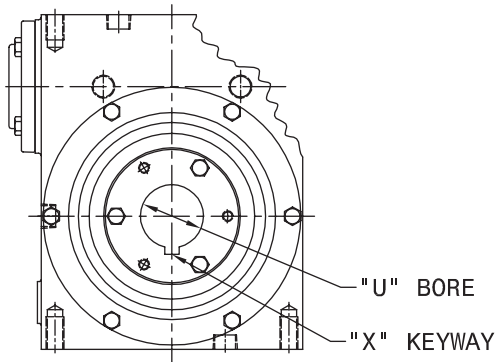

THESE UNITS CAN BE FURNISHED WITH SOLID OUTPUT SHAFT ON SPECIAL ORDERS.

SHAFT MOUNTED UNITS REQUIRE TORQUE ARMS. TORQUE ARM KITS ARE AVAILABLE. SEE PAGE B-95.

STANDARD STYLES AVAILABLE

DIMENSIONS SHOWN ARE FOR REFERENCE ONLY. DOWNLOAD AVAILABLE CAD MODELS AT: WWW.HUBCITYINC.COM

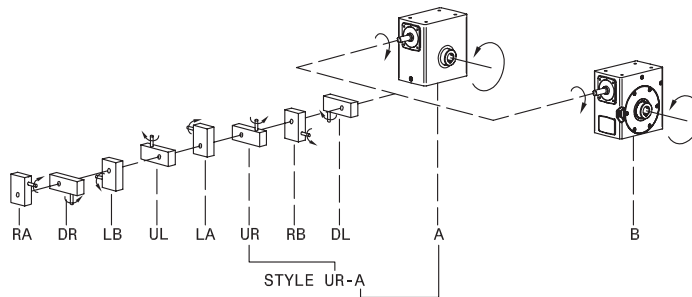

SECONDARY UNIT STYLE SPECIFICATION REQUIRED ON POWERCUBE MODELS 1802 THROUGH 3802 ONLY.

CONSULT FACTORY FOR VERTICAL SHAFT LUBRICATION RECOMMENDATIONS
INPUT SHAFT CAN BE ROTATED IN EITHER DIRECTION



MODELS

1802, 2102, 2402, 2602, 3202, 3802, 4502, 5202, GW6002, GW7002, GW8002, GW10002

B

MODEL	PRIMARY	SECONDARY	C.D.	C.D.1	A	A1	B	B1	D	D1
1802	131	185-56C	1.751	1.334	2.65	2.28	1.374	1.186	1.875	1.562
2102	131	215-56C	2.064	1.334	3.00	2.28	1.500	1.186	2.437	1.562
2402	131	245-56C	2.376	1.334	3.38	2.28	2.062	1.186	2.500	1.562
2602	131	265-56C	2.626	1.334	3.66	2.28	1.874	1.186	2.938	1.562
3202	211	325-143TC	3.251	2.064	4.40	3.00	2.124	1.500	3.250	2.437
3802	211	385-143TC	3.751	2.064	4.90	3.00	2.374	1.500	3.937	2.437
4502	321	455-213TC	4.501	3.251	5.67	4.40	2.499	2.124	4.625	3.250
5202	321	525-213TC	5.168	3.251	6.42	4.40	2.624	2.124	5.375	3.250
GW6002	CUSTOM	GW602	6.000	3.251	10.24	5.02	4.00	2.63	6.50	3.50
GW7002	CUSTOM	GW702	7.000	3.251	10.63	5.02	4.32	2.63	7.59	3.50
GW8002	CUSTOM	GW802	8.000	4.251	11.93	6.10	4.10	2.69	8.86	4.44
GW10002	CUSTOM	GW1002	10.000	5.251	14.34	7.50	5.11	3.63	10.36	5.12

MODEL	E	F	G	H	I	J	K	S	T	T1	WT. LBS.
1802	5.44	1.35	.500/.499	1.54	3.82	1/8 X 1/16	1.16	4.81	2.41	1.56	25
2102	5.87	1.35	.500/.499	1.54	3.82	1/8 X 1/16	1.16	5.56	2.78	1.56	35
2402	6.25	1.35	.500/.499	1.54	3.82	1/8 X 1/16	1.16	5.93	2.97	1.56	44
2602	6.53	1.35	.500/.499	1.54	3.82	1/8 X 1/16	1.16	5.93	2.97	1.56	47
3202	8.12	1.44	.625/.624	1.63	4.63	3/16 X 3/32	1.13	7.56	3.78	2.06	89
3802	8.62	1.44	.625/.624	1.63	4.63	3/16 X 3/32	1.13	7.56	3.78	2.06	105
4502	9.13	2.23	.875/.874	2.48	6.88	3/16 X 3/32	1.91	10.00	5.00	2.60	177
5202	9.88	2.23	.875/.874	2.48	6.88	3/16 X 3/32	1.91	11.13	5.56	2.60	205
GW6002	13.30	2.35	.875	2.38	6.76	3/16 X 3/32	1.75	11.50	5.75	3.40	402
GW7002	12.96	2.35	.875	2.38	6.76	3/16 X 3/32	1.75	13.50	6.75	3.40	478
GW8002	13.94	3.57	1.250	3.47	9.57	1/4 X 1/8	2.88	14.50	7.25	3.62	718
GW10002	17.05	3.40	1.250	3.38	10.88	1/4 X 1/8	3.00	18.50	9.25	4.28	1136

STOCK BORES

MODEL	U	X	KEY FURNISHED	Y
1802	15/16	1/4 X 1/8	1/4 Sq.	10-24 NC X 1/4 LG
	1 (Max.)	1/4 X 1/8	1/4 Sq.	10-24 NC X 1/4 LG
2102	15/16	1/4 X 1/8	1/4 Sq.	5/16 NC X 5/16 LG
	1	1/4 X 1/8	1/4 Sq.	5/16 NC X 5/16 LG
	1-3/16	1/4 X 1/8	1/4 Sq.	5/16 NC X 5/16 LG
	1-1/4 (Max.)	1/4 X 1/8	1/4 Sq.	1/4 NC X 1/4 LG
2402 & 2602	1	1/4 X 1/8	1/4 Sq.	5/16 NC X 5/16 LG
	1-3/16	1/4 X 1/8	1/4 Sq.	5/16 NC X 5/16 LG
	1-1/4	1/4 X 1/8	1/4 Sq.	5/16 NC X 5/16 LG
3202 & 3802	1-7/16 (Max.)	3/8 X 1/8	3/8 X 5/16	1/4 NC X 1/4 LG
	1-7/16	3/8 X 3/16	3/8 Sq.	3/8 NC X 5/8 LG.
GW6002	1-15/16	1/2 X 1/4	1/2 Sq.	3/8 NC X 3/8 LG.
	2	1/2 X 1/4	1/2 Sq.	3/8 NC X 3/8 LG.
	2-3/16 (Max.)	1/2 X 1/8	1/2 Sq.	3/8 NC X 3/8 LG.
	2	1/2 X 1/4	NO	1/2 NC X 3/4 LG
GW6002	2-3/16	1/2 X 1/4	NO	1/2 NC X 3/4 LG
	2-1/4	1/2 X 1/4	NO	1/2 NC X 3/4 LG
	2-7/16	5/8 X 5/16	NO	1/2 NC X 3/4 LG
	2-1/2	5/8 X 5/16	NO	1/2 NC X 3/4 LG
	2-11/16	5/8 X 5/16	NO	1/2 NC X 3/4 LG
	2-15/16	3/4 X 3/8	NO	1/2 NC X 3/4 LG
	3	3/4 X 3/8	NO	1/2 NC X 3/4 LG
	3-3/16	3/4 X 3/8	NO	1/2 NC X 3/4 LG
	3-7/16	7/8 X 7/16	NO	1/2 NC X 3/4 LG

BORE TOLERANCE NOMINAL + .002 (MODELS 1802 THRU 6002)
BORE TOLERANCE NOMINAL + .0025 (MODELS GW7002 THRU GW10002)

STOCK BORES (continued)

MODEL	U	X	KEY FURNISHED	Y
GW7002	2-7/16	5/8 X 5/16	NO	1/2 NC X 1/2 LG
	2-1/2	5/8 X 5/16	NO	1/2 NC X 1/2 LG
	2-11/16	5/8 X 5/16	NO	1/2 NC X 1/2 LG
	2-15/16	3/4 X 3/8	NO	1/2 NC X 1/2 LG
	3	3/4 X 3/8	NO	1/2 NC X 1/2 LG
	3-7/16	3/4 X 3/8	NO	1/2 NC X 1/2 LG
GW8002	3-15/16 (Max.)	1 X 1/4	1 X 3/4	1/2 NC X 1/2 LG
	3-7/16	7/8 X 7/16	NO	1/2 NC X 1/2 LG
	3-15/16	7/8 X 7/16	NO	1/2 NC X 1/2 LG
	4-3/16	1 X 1/2	NO	1/2 NC X 1/2 LG
GW10002	4-7/16 (Max.)	1 X 1/4	1 X 3/4	1/2 NC X 1/2 LG
	3-7/16	7/8 X 7/16	NO	5/8 NC X 5/8 LG
	3-15/16	7/8 X 7/16	NO	5/8 NC X 5/8 LG
	4-7/16	1 X 1/2	NO	5/8 NC X 5/8 LG
	4-15/16	1-1/4 X 5/8	NO	5/8 NC X 5/8 LG
5-7/16 (Max.)	1-1/4 X 5/16	1-1/4 X 15/16	5/8 NC X 5/8 LG	

QD BUSHING BORES

MODEL	U	X	Y	PP	RR	KEY	TYPE	KIT*	
4502	1-15/16	1/2 X 1/4	-	4-5/8	3/8	1/2 Sq.	SF	0229-02683	
	2		-					0229-02684	
	2-3/16		-					0229-02685	
	2-7/16	5/8 X 3/16	-			5/8 X 1/2		0229-02686	
	2-15/16	3/4 X 1/32	-			3/4 X 13/32		0229-02687	
	2-3/16	1/2 X 1/4	-			1/2 Sq.		0229-02688	
5202	2-7/16	5/8 X 3/16	-	6	7/16	5/8 Sq.	E	0229-02689	
	2-15/16	-	-			3/4 X 1/2		0229-02690	
	3	3/4 X 1/8	-			-		0229-02691	
	3-3/16	-	-			-		0229-02692	
	3-7/16	7/8 X 1/16	-			-		7/8 X 1/2	0229-02693

* ORDER BY QD BUSHING KIT NUMBER. BUSHING KITS ARE NOT INCLUDED IN REDUCER PRICE. KIT INCLUDES TWO BUSHINGS WITH KEYWAYS AND ONE KEY.

DOUBLE REDUCTION



MODELS

1803, 2103, 2403, 2603, 3203, 3803

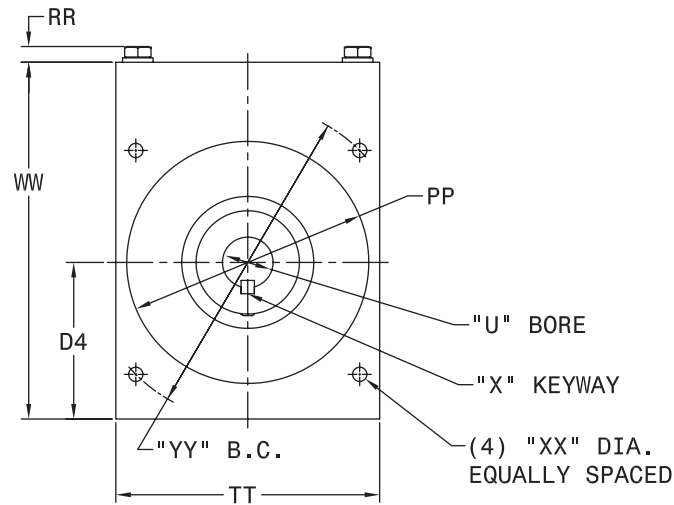
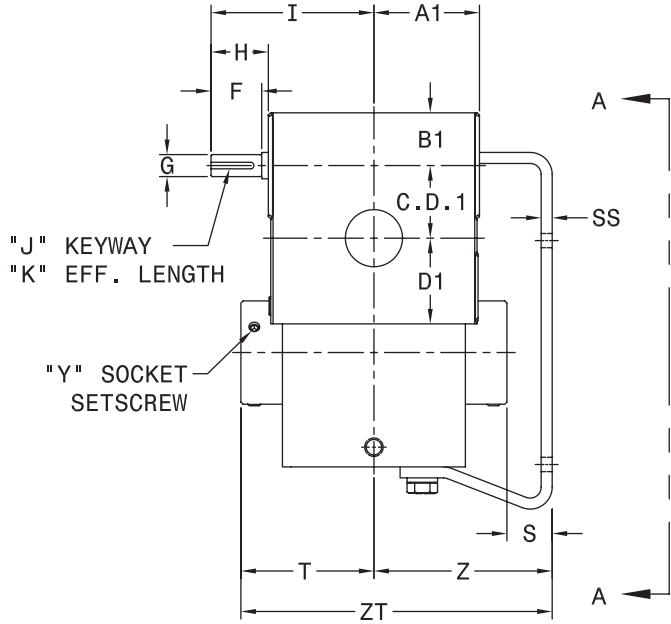
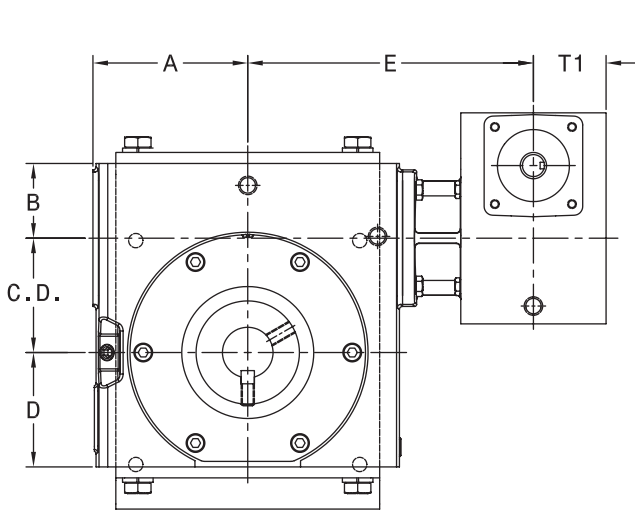

VIEW A-A

FOR LUBRICATION AND INSTALLATION INSTRUCTIONS REFER TO SECTION R.

THESE UNITS CAN BE FURNISHED WITH SOLID OUTPUT SHAFT ON SPECIAL ORDERS.

DIMENSIONS SHOWN ARE FOR REFERENCE ONLY.
 DOWNLOAD AVAILABLE CAD MODELS AT:
WWW.HUBCITYINC.COM

STANDARD STYLES AVAILABLE

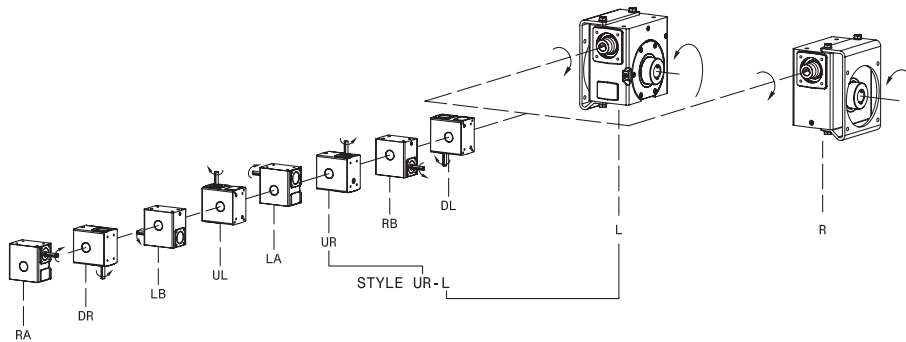

CONSULT FACTORY FOR VERTICAL SHAFT LUBRICATION RECOMMENDATIONS
 INPUT SHAFT CAN BE ROTATED IN EITHER DIRECTION



MODELS

1803, 2103, 2403, 2603, 3203, 3803

B

MODEL	PRIMARY	SECONDARY	C.D.	C.D.1	A	A1	B	B1	D	D1
1803	131	186-56C	1.751	1.334	2.65	2.28	1.374	1.186	1.875	1.562
2103	131	216-56C	2.064	1.334	3.00	2.28	1.500	1.186	2.437	1.562
2403	131	246-56C	2.376	1.334	3.38	2.28	2.062	1.186	2.500	1.562
2603	131	266-56C	2.626	1.334	3.66	2.28	1.874	1.186	2.938	1.562
3203	211	326-143TC	3.251	2.064	4.40	3.00	2.124	1.500	3.250	2.437
3803	211	386-143TC	3.751	2.064	4.90	3.00	2.374	1.500	3.937	2.437

MODEL	E	F	G	H	I	J	K	T1
1803	5.44	1.35	.500/.499	1.54	3.82	1/8 X 1/16	1.16	1.56
2103	5.87	1.35	.500/.499	1.54	3.82	1/8 X 1/16	1.16	1.56
2403	6.25	1.35	.500/.499	1.54	3.82	1/8 X 1/16	1.16	1.56
2603	6.53	1.35	.500/.499	1.54	3.82	1/8 X 1/16	1.16	1.56
3203	8.12	1.44	.625/.624	1.63	4.63	3/16 X 3/32	1.13	2.06
3803	8.62	1.44	.625/.624	1.63	4.63	3/16 X 3/32	1.13	2.06

MODEL	D4	S	T	Z	PP	RR	SS	TT	WW	XX	YY	ZT	Wt. Lbs.
1803	3.13	.91	2.41	3.31	4.25	.22	.25	4.88	6.50	11/32	5.875	5.71	28
2103	3.75	.85	2.78	3.63	4.75	.33	.31	5.75	7.63	13/32	7.000	6.41	40
2403	3.61	.75	2.97	3.72	5.00	.33	.25	6.00	8.30	13/32	7.500	6.69	49
2603	3.89	.66	2.97	3.63	5.75	.33	.31	6.75	8.70	13/32	8.000	6.60	53
3203	4.45	.22	3.78	4.00	6.88	.44	.31	7.50	10.14	13/32	9.000	7.78	97
3803	5.09	.72	3.78	4.50	7.50	.44	.31	8.25	11.53	9/16	10.000	8.28	115

DOUBLE REDUCTION

STOCK BORES

MODEL	U	X	KEY FURNISHED	Y
1803	15/16	1/4 X 1/8	1/4 Sq.	10-24 NC X 1/4 LG
	1 (Max.)	1/4 X 1/8	1/4 Sq.	10-24 NC X 1/4 LG
2103	15/16	1/4 X 1/8	1/4 Sq.	5/16 NC X 5/16 LG
	1	1/4 X 1/8	1/4 Sq.	5/16 NC X 5/16 LG
	1-3/16	1/4 X 1/8	1/4 Sq.	5/16 NC X 5/16 LG
	1-1/4 (Max.)	1/4 X 1/8	1/4 Sq.	1/4 NC X 1/4 LG
2403 & 2603	1	1/4 X 1/8	1/4 Sq.	5/16 NC X 5/16 LG
	1-3/16	1/4 X 1/8	1/4 Sq.	5/16 NC X 5/16 LG
	1-1/4	1/4 X 1/8	1/4 Sq.	5/16 NC X 5/16 LG
3203 & 3803	1-7/16 (Max.)	3/8 X 1/8	3/8 X 5/16	1/4 NC X 1/4 LG
	1-7/16	3/8 X 3/16	3/8 Sq.	3/8 NC X 5/8 LG
	1-15/16	1/2 X 1/4	1/2 Sq.	3/8 NC X 3/8 LG
	2	1/2 X 1/4	1/2 Sq.	3/8 NC X 3/8 LG
	2-3/16 (Max.)	1/2 X 1/8	1/2 Sq.	3/8 NC X 3/8 LG

BORE TOLERANCE NOMINAL + .002



MODELS

4503, 5203

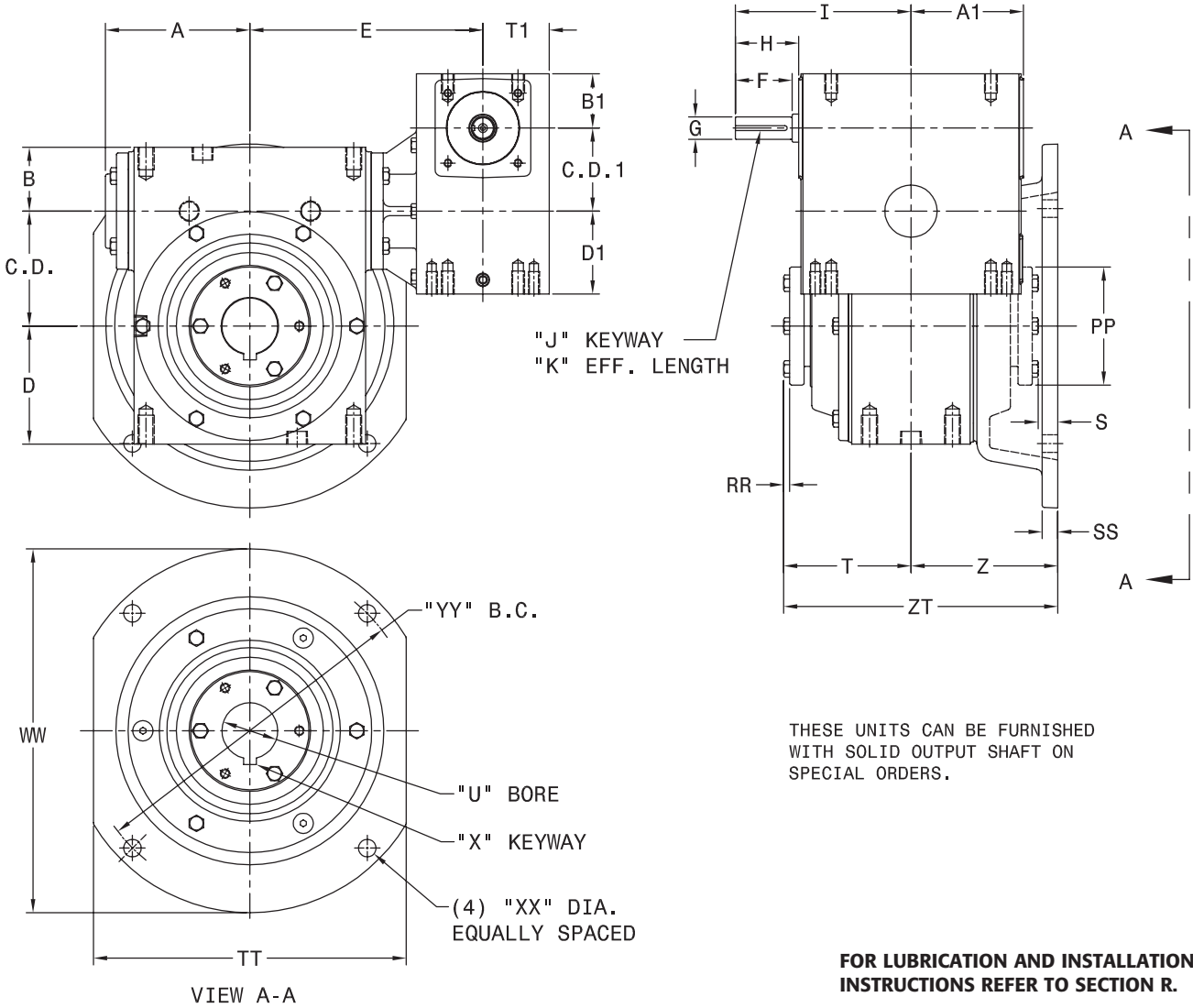

STANDARD STYLES AVAILABLE

DIMENSIONS SHOWN ARE FOR REFERENCE ONLY.
 DOWNLOAD AVAILABLE CAD MODELS AT:
WWW.HUBCITYINC.COM

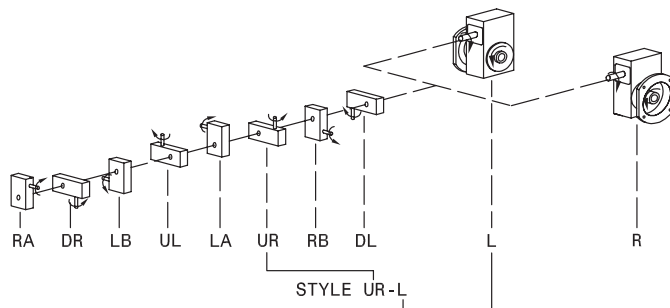

CONSULT FACTORY FOR VERTICAL SHAFT LUBRICATION RECOMMENDATIONS
 INPUT SHAFT CAN BE ROTATED IN EITHER DIRECTION



MODELS

4503, 5203

B

MODEL	PRIMARY	SECONDARY	C.D.	C.D.1	A	A1	B	B1	D	D1
4503	321	456-213TC	4.501	3.251	5.67	4.40	2.499	2.124	4.625	3.250
5203	321	526-213TC	5.168	3.251	6.42	4.40	2.624	2.124	5.375	3.250

MODEL	E	F	G	H	I	J	K	S	T	T1	Z
4503	9.13	2.23	.875/.874	2.48	6.88	3/16 X 3/32	1.91	.75	5.00	2.60	5.75
5203	9.88	2.23	.875/.874	2.48	6.88	3/16 X 3/32	1.91	1.44	5.56	2.60	7.00

MODEL	SS	TT	WW	XX	YY	ZT	WT. LBS.
4503	.63	12.25	14.25	11/16	13.00	10.75	185
5203	.75	12.50	15.50	11/16	14.00	12.56	214

QD BUSHING BORES

MODEL	U	X	PP	RR	KEY	TYPE	KIT*
4503	1-15/16	1/2 X 1/4	4-5/8	3/8	1/2 Sq.	SF	0229-02683
	2						0229-02684
	2-3/16	5/8 X 3/16			5/8 x 1/2		0229-02685
	2-7/16						0229-02686
2-15/16	3/4 X 1/32	3/4 x 13/32	0229-02687				
5203	2-3/16	1/2 X 1/4	6	7/16	1/2 Sq.	E	0229-02688
	2-7/16	5/8 X 3/16			5/8 Sq.		0229-02689
	2-15/16	3/4 X 1/8			3/4 X 1/2		0229-02690
	3						0229-02691
	3-3/16						0229-02692
3-7/16	7/8 X 1/16	7/8 X 1/2	0229-02693				

* ORDER BY QD BUSHING KIT NUMBER. BUSHING KITS ARE NOT INCLUDED IN REDUCER PRICE. KIT INCLUDES TWO BUSHINGS WITH KEYWAYS AND ONE KEY.

BORE TOLERANCE NOMINAL +.002

DOUBLE REDUCTION



MODELS

1304, 1804, 2104, 2404, 2604, 3204, 3804, 4504, 5204, GW6004, GW7004, GW8004, GW10004

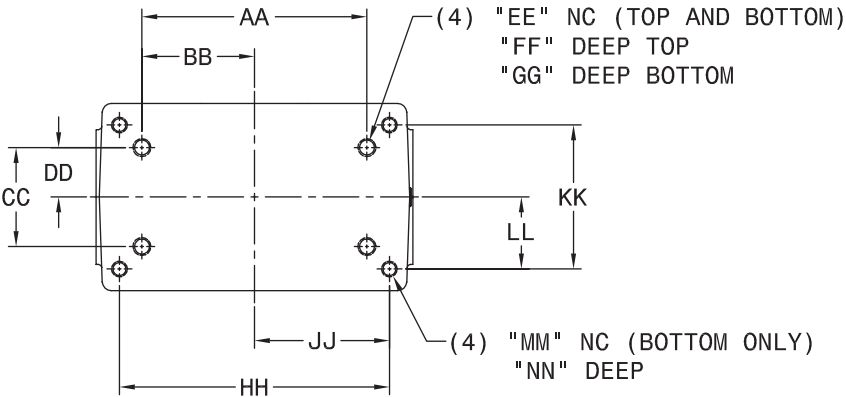
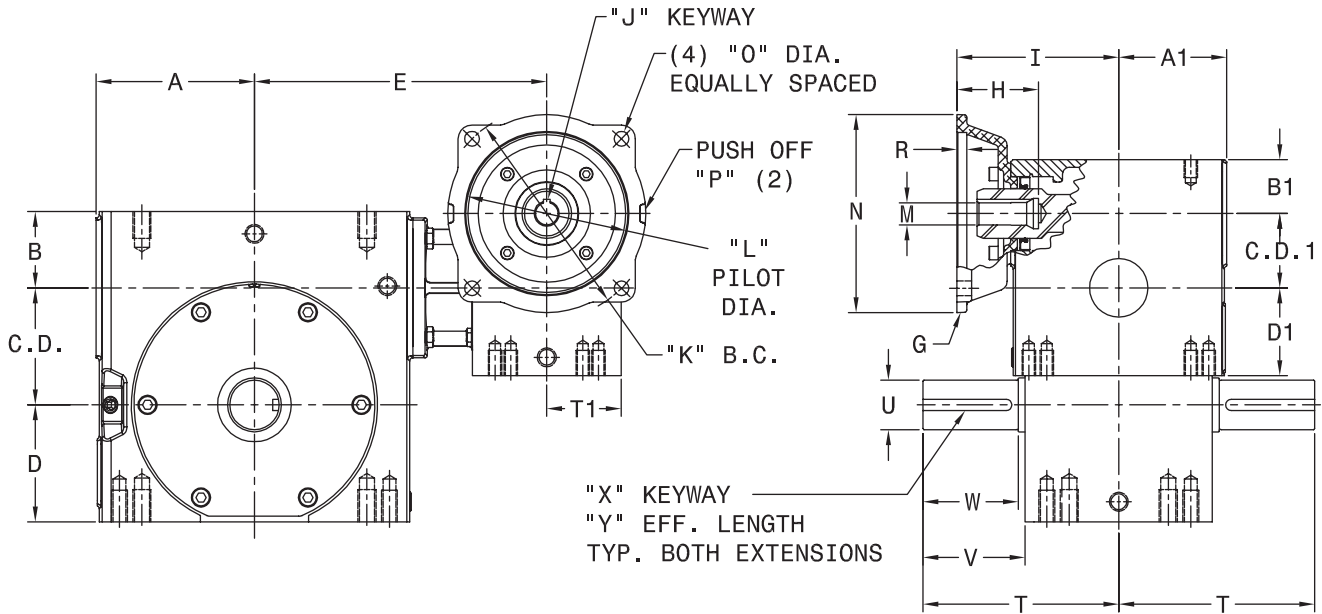

FOR LUBRICATION AND INSTALLATION INSTRUCTIONS REFER TO SECTION R.

SPECIAL, 48C, METRIC AND SAE HYDRAULIC INPUT FLANGES AVAILABLE. CONSULT FACTORY FOR COMPLETE SPECIFICATIONS.

STANDARD STYLES AVAILABLE

DIMENSIONS SHOWN ARE FOR REFERENCE ONLY. DOWNLOAD AVAILABLE CAD MODELS AT: WWW.HUBCITYINC.COM

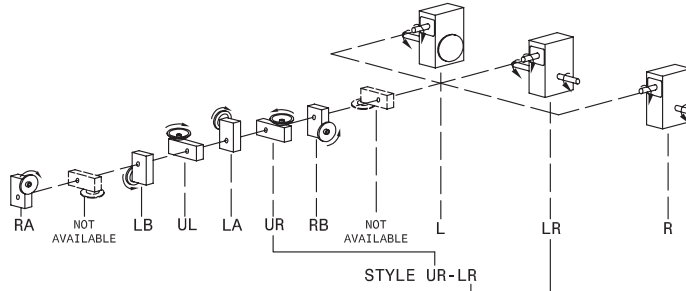

CONSULT FACTORY FOR VERTICAL SHAFT LUBRICATION RECOMMENDATIONS
 INPUT SHAFT CAN BE ROTATED IN EITHER DIRECTION



MODELS

1304, 1804, 2104, 2404, 2604, 3204, 3804, 4504, 5204, GW6004, GW7004, GW8004, GW10004

SECONDARY UNIT DIMENSIONS

MODEL	PRIMARY	SECONDARY	C.D.	A	B	D	E	T	U	V	W	X	Y
1304	134	134-56C	1.334	2.28	1.186	1.562	5.07	3.25	.625/.624	1.69	N/A	3/16 X 3/32	1.38
1804	134	184-56C	1.751	2.65	1.374	1.875	5.44	3.50	.750/.749	1.78	1.54	3/16 X 3/32	1.41
2104	134	214-56C	2.064	3.00	1.500	2.437	5.87	4.25	.875/.874	2.19	1.95	3/16 X 3/32	1.83
2404	134	244-56C	2.376	3.38	2.062	2.500	6.25	4.50	1.125/1.124	2.31	2.06	1/4 X 1/8	1.74
2604	134	264-56C	2.626	3.66	1.874	2.938	6.53	4.50	1.250/1.249	2.25	N/A	1/4 X 1/8	1.85
3204	214	324-143TC	3.251	4.40	2.124	3.250	8.12	5.44	1.375/1.374	2.84	N/A	5/16 X 5/32	2.31
3804	214	384-143TC	3.751	4.90	2.374	3.937	8.62	6.69	1.500/1.499	3.88	N/A	3/8 X 3/16	3.16
4504	324	454-213TC	4.501	5.67	2.499	4.625	9.13	7.25	1.625/1.624	4.18	3.90	3/8 X 3/16	3.28
5204	324	524-213TC	5.168	6.42	2.624	5.375	9.88	7.81	1.750/1.749	4.47	4.17	3/8 X 3/16	3.50
GW6004	CUSTOM	GW601	6.000	10.24	4.00	6.50	13.30	10.00	2.500	4.65	N/A	5/8 X 5/16	4.00
GW7004	CUSTOM	GW701	7.000	10.63	4.32	7.59	12.96	11.76	2.750	5.65	N/A	5/8 X 5/16	4.00
GW8004	CUSTOM	GW801	8.000	11.93	4.10	8.86	13.94	12.25	3.000	5.98	5.26	3/4 X 3/8	4.50
GW10004	CUSTOM	GW1001	10.000	14.34	5.11	10.36	17.05	14.75	3.750	6.76	N/A	7/8 X 7/16	5.00

MODEL	AA	BB	CC	DD	EE	FF	GG	HH	JJ	KK	LL	MM	NN	WT. LBS.
1304	2.250	1.125	1.625	.812	1/4 UNC	.50	.50	3.250	1.625	2.000	1.000	5/16 NC	.75	21
1804	3.125	1.562	1.625	.812	1/4 UNC	.50	.50	4.188	2.094	2.750	1.375	5/16 NC	.75	26
2104	4.000	2.000	2.000	1.000	3/8 UNC	.50	.70	5.000	2.500	2.875	1.438	3/8 NC	.70	35
2404	5.000	2.500	2.875	1.438	3/8 UNC	.70	.70	N/A	N/A	N/A	N/A	N/A	N/A	43
2604	4.875	2.437	2.688	1.344	3/8 UNC	.70	.70	6.375	3.188	3.375	1.688	3/8 NC	.70	48
3204	6.250	3.125	2.750	1.375	1/2 UNC	.75	.90	7.500	3.750	4.000	2.000	7/16 NC	.88	85
3804	6.875	3.438	3.000	1.500	1/2 UNC	.94	1.00	8.500	4.250	4.750	2.375	1/2 NC	1.00	110
4504	8.125	4.063	3.250	1.625	5/8 UNC	.88	1.13	N/A	N/A	N/A	N/A	N/A	N/A	176
5204	9.500	4.750	3.750	1.875	5/8 UNC	1.00	1.25	N/A	N/A	N/A	N/A	N/A	N/A	202
GW6004	12.750	6.380	6.380	3.190	5/8 UNC	1.00	1.00	N/A	N/A	N/A	N/A	N/A	N/A	406
GW7004	12.500	6.250	5.500	2.750	1 UNC	1.56	1.56	N/A	N/A	N/A	N/A	N/A	N/A	482
GW8004	14.250	7.125	6.500	3.250	1 UNC	1.66	1.66	N/A	N/A	N/A	N/A	N/A	N/A	728
GW10004	17.750	8.875	6.875	3.438	1-1/4 UNC	2.04	2.04	N/A	N/A	N/A	N/A	N/A	N/A	1151

PRIMARY UNIT DIMENSIONS

MODEL	G	H	I	J	K	L	M	N	O	P	R	C.D.1	A1	B1	D1	T1														
1304	56C	2.27	3.63	3/16 X 3/32	5.875	4.501/4.503	.625	5.50	13/32	SLOTS	.19	1.334	2.28	1.186	1.562	1.56														
1804	56C	2.27	3.63	3/16 X 3/32	5.875	4.501/4.503	.625	5.50	13/32	SLOTS	.19	1.334	2.28	1.186	1.562	1.56														
2104	56C	2.27	3.63	3/16 X 3/32	5.875	4.501/4.503	.625	5.50	13/32	SLOTS	.19	1.334	2.28	1.186	1.562	1.56														
2404	56C	2.27	3.63	3/16 X 3/32	5.875	4.501/4.503	.625	5.50	13/32	SLOTS	.19	1.334	2.28	1.186	1.562	1.56														
2604	56C	2.27	3.63	3/16 X 3/32	5.875	4.501/4.503	.625	5.50	13/32	SLOTS	.19	1.334	2.28	1.186	1.562	1.56														
3204	56C	2.27	4.50	3/16 X 3/32	5.875	4.501/4.503	.625	5.50	13/32	SLOTS	.19	2.064	3.00	1.500	2.437	2.06														
	143TC	2.38					.875																							
3804	56C	2.27	4.50	3/16 X 3/32	5.875	4.501/4.503	.625	5.50	13/32	SLOTS	.19	2.064	3.00	1.500	2.437	2.06														
	143TC	2.38					.875																							
4504	56C	2.27	6.00	3/16 X 3/32	5.875	4.501/4.503	.625	5.50	13/32	SLOTS	.19	3.251	4.40	2.124	3.250	2.60														
	143TC	2.38					.875																							
	182TC	3.19					6.38										1/4 X 1/8	7.250	8.501/8.504	1.125	9.00	17/32	HOLES	.44						
5204	56C	2.27	6.00	3/16 X 3/32	5.875	4.501/4.503	.625	5.50	13/32	SLOTS	.19	3.251	4.40	2.124	3.250	2.60														
	143TC	2.38					.875																							
	182TC	3.19					6.38										1/4 X 1/8	7.250	8.501/8.504	1.125	9.00	17/32	HOLES	.44						
GW6004	56C	2.33	5.88	3/16 X 3/32	5.875	4.501/4.503	.625	5.88	13/32	N/A	.19	3.251	5.02	2.63	3.50	3.40														
	143TC						.875																							
	182TC						2.94										6.50	1/4 X 1/8	7.250	8.501/8.504	1.125	9.00	17/32	N/A	.19	3.251	5.02	2.63	3.50	3.40
	213TC						3.10										6.94	5/16 X 5/32			1.375									
GW7004	56C	2.33	5.88	3/16 X 3/32	5.875	4.501/4.503	.625	5.88	13/32	N/A	.19	3.251	5.02	2.63	3.50	3.40														
	143TC						.875																							
	182TC						2.94										6.50	1/4 X 1/8	7.250	8.501/8.504	1.125	9.00	17/32	N/A	.19	3.251	5.02	2.63	3.50	3.40
	213TC						3.10										6.94	5/16 X 5/32			1.375									
GW8004	56C	2.33	6.45	3/16 X 3/32	5.875	4.501/4.503	.625	5.88	13/32	N/A	.19	4.251	6.10	2.69	4.44	3.62														
	143TC						.875																							
	182TC						3.44										7.40	1/4 X 1/8	7.250	8.501/8.504	1.125	9.00	17/32	N/A	.19	4.251	6.10	2.69	4.44	3.62
	213TC																	5/16 X 5/32			1.375									
256TC	4.00	7.96	3/8 X 3/16			1.625																								
GW10004	56C	2.44	7.85	3/16 X 3/32	5.875	4.501/4.503	.625	5.88	13/32	N/A	.19	5.251	7.50	3.63	5.12	4.28														
	143TC						.875																							
	182TC						3.44										8.80	1/4 X 1/8	7.250	8.501/8.504	1.125	9.00	17/32	N/A	.19	5.251	7.50	3.63	5.12	4.28
	213TC																	5/16 X 5/32			1.375									
256TC	4.00	9.36	3/8 X 3/16			1.625																								

B

DOUBLE REDUCTION



MODELS

1805, 2105, 2405, 2605, 3205, 3805, 4505, 5205, GW6005, GW7005, GW8005, GW10005

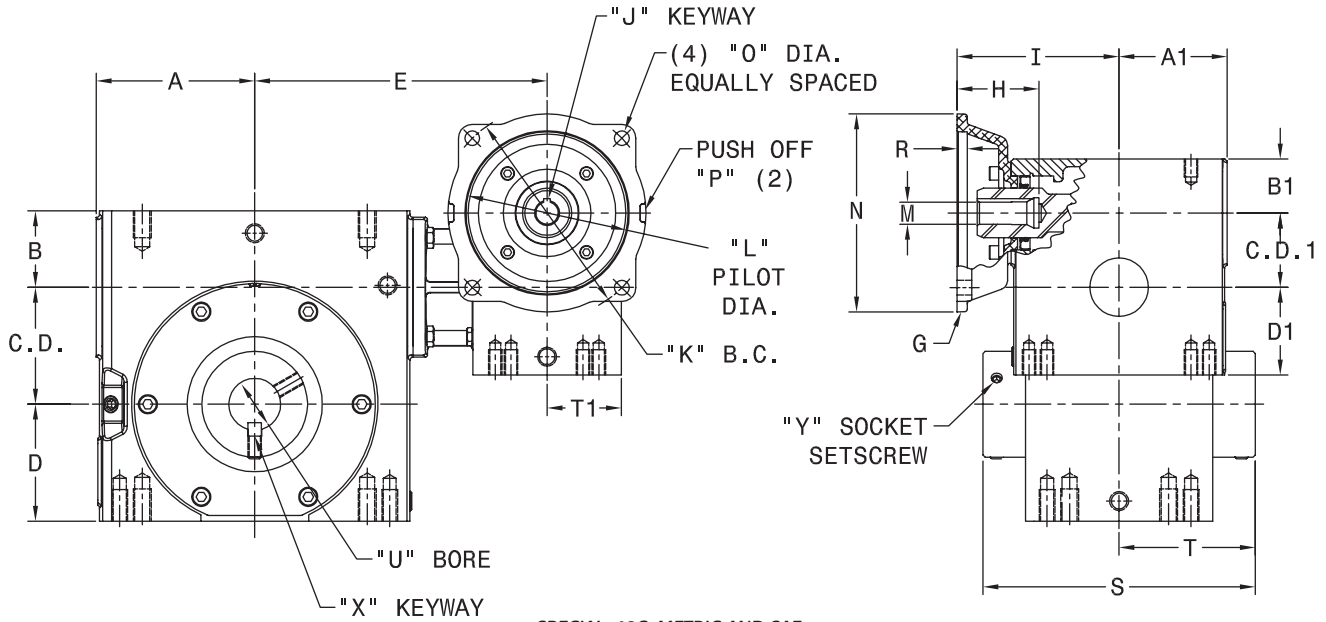

SHAFT MOUNTED UNITS REQUIRE TORQUE ARMS. TORQUE ARM KITS ARE AVAILABLE. SEE PAGE B-95.

SPECIAL, 48C, METRIC AND SAE HYDRAULIC INPUT FLANGES AVAILABLE. CONSULT FACTORY FOR COMPLETE SPECIFICATIONS.

FOR LUBRICATION AND INSTALLATION INSTRUCTIONS REFER TO SECTION R.

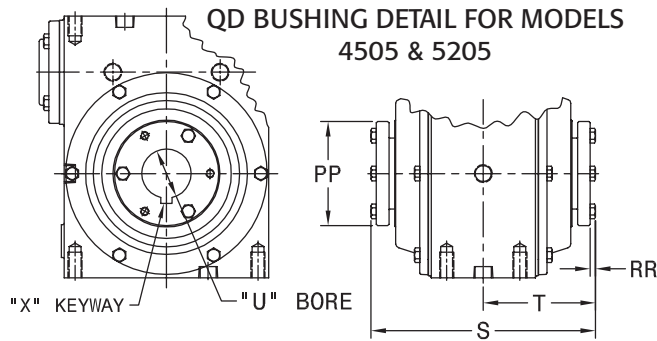

QD BUSHING BORES

MODEL	U	X	Y	PP	RR	KEY	TYPE	KIT*
4505	1-15/16	1/2 X 1/4	-	4-5/8	3/8	1/2 Sq.	SF	0229-02683
	2		-					0229-02684
	2-3/16	-	0229-02685					
	2-7/16	5/8 X 3/16	-			5/8 x 1/2		0229-02686
	2-15/16	3/4 X 1/32	-			3/4 x 13/32		0229-02687
5205	2-3/16	1/2 X 1/4	-	6	7/16	1/2 Sq.	E	0229-02688
	2-7/16	5/8 X 3/16	-			5/8 Sq.		0229-02689
	2-15/16	-	-			3/4 X 1/2		0229-02690
	3	3/4 X 1/8	-					0229-02691
	3-3/16	-	-					0229-02692
	3-7/16	7/8 X 1/16	-			7/8 X 1/2		0229-02693

* ORDER BY QD BUSHING KIT NUMBER. BUSHING KITS ARE NOT INCLUDED IN REDUCER PRICE. KIT INCLUDES TWO BUSHINGS WITH KEYWAYS AND ONE KEY.

STANDARD STYLES AVAILABLE

DIMENSIONS SHOWN ARE FOR REFERENCE ONLY. DOWNLOAD AVAILABLE CAD MODELS AT: WWW.HUBCITYINC.COM

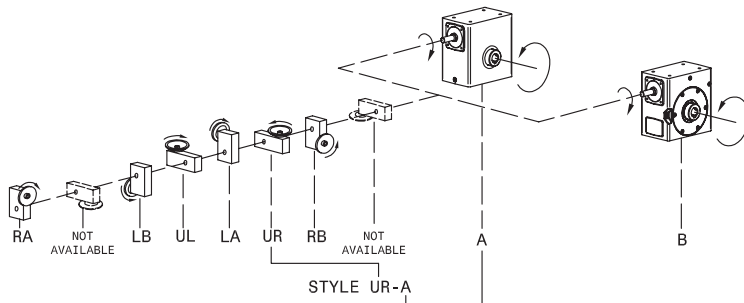

SECONDARY UNIT STYLE SPECIFICATION REQUIRED ON POWERCUBE MODELS 1805 THROUGH 3805 ONLY.

CONSULT FACTORY FOR VERTICAL SHAFT LUBRICATION RECOMMENDATIONS
INPUT SHAFT CAN BE ROTATED IN EITHER DIRECTION



MODELS

1805, 2105, 2405, 2605, 3205, 3805, 4505, 5205, GW6005, GW7005, GW8005, GW10005

SECONDARY UNIT DIMENSIONS

MODEL	PRIMARY	SECONDARY	C.D.	A	B	D	E	S	T	WT. LBS.
1805	134	185-56C	1.751	2.65	1.374	1.875	5.44	4.81	2.41	26
2105	134	215-56C	2.064	3.00	1.500	2.437	5.87	5.56	2.78	36
2405	134	245-56C	2.376	3.38	2.062	2.500	6.25	5.93	2.97	45
2605	134	265-56C	2.626	3.66	1.874	2.938	6.53	5.93	2.97	48
3205	214	325-143TC	3.251	4.40	2.124	3.250	8.12	7.56	3.78	91
3805	214	385-143TC	3.751	4.90	2.374	3.937	8.62	7.56	3.78	107
4505	324	455-213TC	4.501	5.67	2.499	4.625	9.13	10.00	5.00	181
5205	324	525-213TC	5.168	6.42	2.624	5.375	9.88	11.13	5.56	209
GW6005	CUSTOM	GW602	6.000	10.24	4.00	6.50	13.30	11.50	5.75	406
GW7005	CUSTOM	GW702	7.000	10.63	4.32	7.59	12.96	13.50	6.75	482
GW8005	CUSTOM	GW802	8.000	11.93	4.10	8.86	13.94	14.50	7.25	728
GW10005	CUSTOM	GW1002	10.000	14.34	5.11	10.36	17.05	18.50	9.25	1151

B

PRIMARY UNIT DIMENSIONS

MODEL	G	H	I	J	K	L	M	N	O	P	R	C.D.1	A1	B1	D1	T1
1805	56C	2.27	3.63	3/16 X 3/32	5.875	4.501/4.503	.625	5.50	13/32	SLOTS	.19	1.334	2.28	1.186	1.562	1.56
2105	56C	2.27	3.63	3/16 X 3/32	5.875	4.501/4.503	.625	5.50	13/32	SLOTS	.19	1.334	2.28	1.186	1.562	1.56
2405	56C	2.27	3.63	3/16 X 3/32	5.875	4.501/4.503	.625	5.50	13/32	SLOTS	.19	1.334	2.28	1.186	1.562	1.56
2605	56C	2.27	3.63	3/16 X 3/32	5.875	4.501/4.503	.625	5.50	13/32	SLOTS	.19	1.334	2.28	1.186	1.562	1.56
3205	56C	2.27	4.50	3/16 X 3/32	5.875	4.501/4.503	.625	5.50	13/32	SLOTS	.19	2.064	3.00	1.500	2.437	2.06
	143TC	2.38					.875									
3804	56C	2.27	4.50	3/16 X 3/32	5.875	4.501/4.503	.625	5.50	13/32	SLOTS	.19	2.064	3.00	1.500	2.437	2.06
	143TC	2.38					.875									
4505	56C	2.27	6.00	3/16 X 3/32	5.875	4.501/4.503	.625	5.50	13/32	SLOTS	.19	3.251	4.40	2.124	3.250	2.60
	143TC	2.38					.875									
	182TC	3.19					6.38									
5205	56C	2.27	6.00	3/16 X 3/32	5.875	4.501/4.503	.625	5.50	13/32	SLOTS	.19	3.251	4.40	2.124	3.250	2.60
	143TC	2.38					.875									
	182TC	3.19					6.38									
GW6005	56C	2.33	5.88	3/16 X 3/32	5.875	4.501/4.503	.625	5.88	13/32	N/A	.19	3.251	5.02	2.63	3.50	3.40
	143TC						.875									
	182TC	2.94	6.50	1/4 X 1/8	7.250	8.501/8.504	1.125	9.00	17/32	N/A	.19	3.251	5.02	2.63	3.50	3.40
	213TC	3.10	6.94	5/16 X 5/32			1.375									
GW7005	56C	2.33	5.88	3/16 X 3/32	5.875	4.501/4.503	.625	5.88	13/32	N/A	.19	3.251	5.02	2.63	3.50	3.40
	143TC						.875									
	182TC	2.94	6.50	1/4 X 1/8	7.250	8.501/8.504	1.125	9.00	17/32	N/A	.19	3.251	5.02	2.63	3.50	3.40
	213TC	3.10	6.94	5/16 X 5/32			1.375									
GW8005	56C	2.33	6.45	3/16 X 3/32	5.875	4.501/4.503	.625	5.88	13/32	N/A	.19	4.251	6.10	2.69	4.44	3.62
	143TC						.875									
	182TC	3.44	7.40	1/4 X 1/8	7.250	8.501/8.504	1.125	9.00	17/32	N/A	.19	4.251	6.10	2.69	4.44	3.62
	213TC			5/16 X 5/32			1.375									
256TC	4.00	7.96	3/8 X 3/16			1.625										
GW10005	56C	2.44	7.85	3/16 X 3/32	5.875	4.501/4.503	.625	5.88	13/32	N/A	.19	5.251	7.50	3.63	5.12	4.28
	143TC						.875									
	182TC	3.44	8.80	1/4 X 1/8	7.250	8.501/8.504	1.125	9.00	17/32	N/A	.19	5.251	7.50	3.63	5.12	4.28
	213TC			5/16 X 5/32			1.375									
	256TC	4.00	9.36	3/8 X 3/16			1.625									

DOUBLE REDUCTION

STOCK BORES

MODEL	U	X	KEY FURNISHED	Y
1805	15/16	1/4 X 1/8	1/4 Sq.	10-24 NC X 1/4 LG
	1 (Max.)	1/4 X 1/8	1/4 Sq.	10-24 NC X 1/4 LG
2105	15/16	1/4 X 1/8	1/4 Sq.	5/16 NC X 5/16 LG
	1	1/4 X 1/8	1/4 Sq.	5/16 NC X 5/16 LG
	1-3/16	1/4 X 1/8	1/4 Sq.	5/16 NC X 5/16 LG
	1-1/4 (Max.)	1/4 X 1/8	1/4 Sq.	1/4 NC X 1/4 LG
2405 & 2605	1	1/4 X 1/8	1/4 Sq.	5/16 NC X 5/16 LG
	1-3/16	1/4 X 1/8	1/4 Sq.	5/16 NC X 5/16 LG
	1-1/4	1/4 X 1/8	1/4 Sq.	5/16 NC X 5/16 LG
	1-7/16 (Max.)	3/8 X 1/8	3/8 X 5/16	1/4 NC X 1/4 LG
3205 & 3805	1-7/16	3/8 X 3/16	3/8 Sq.	3/8 NC X 5/8 LG.
	1-15/16	1/2 X 1/4	1/2 Sq.	3/8 NC X 3/8 LG.
	2	1/2 X 1/4	1/2 Sq.	3/8 NC X 3/8 LG.
	2-3/16 (Max.)	1/2 X 1/8	1/2 Sq.	3/8 NC X 3/8 LG.
GW6005	2	1/2 x 1/4	NO	1/2 NC X 3/4 LG
	2-3/16	1/2 x 1/4	NO	1/2 NC X 3/4 LG
	2-1/4	1/2 x 1/4	NO	1/2 NC X 3/4 LG
	2-7/16	5/8 x 5/16	NO	1/2 NC X 3/4 LG
	2-1/2	5/8 x 5/16	NO	1/2 NC X 3/4 LG
	2-11/16	5/8 x 5/16	NO	1/2 NC X 3/4 LG

STOCK BORES

MODEL	U	X	KEY FURNISHED	Y
GW6005 (con't)	2-15/16	3/4 x 3/8	NO	1/2 NC X 3/4 LG
	3	3/4 x 3/8	NO	1/2 NC X 3/4 LG
	3-3/16	3/4 x 3/8	NO	1/2 NC X 3/4 LG
	3-7/16	7/8 x 7/16	NO	1/2 NC X 3/4 LG
GW7005	2-7/16	5/8 X 5/16	NO	1/2 NC X 1/2 LG
	2-1/2	5/8 X 5/16	NO	1/2 NC X 1/2 LG
	2-11/16	5/8 X 5/16	NO	1/2 NC X 1/2 LG
	2-15/16	3/4 X 3/8	NO	1/2 NC X 1/2 LG
	3	3/4 X 3/8	NO	1/2 NC X 1/2 LG
	3-7/16	3/4 X 3/8	NO	1/2 NC X 1/2 LG
	3-15/16 (Max.)	1 X 1/4	1 X 3/4	1/2 NC X 1/2 LG
GW8005	3-7/16	7/8 X 7/16	NO	1/2 NC X 1/2 LG
	3-15/16	7/8 X 7/16	NO	1/2 NC X 1/2 LG
	4-3/16	1 X 1/2	NO	1/2 NC X 1/2 LG
4-7/16 (Max.)	1 X 1/4	1 X 3/4	1/2 NC X 1/2 LG	
GW10005	3-7/16	7/8 X 7/16	NO	5/8 NC X 5/8 LG
	3-15/16	7/8 X 7/16	NO	5/8 NC X 5/8 LG
	4-7/16	1 X 1/2	NO	5/8 NC X 5/8 LG
	4-15/16	1-1/4 X 5/8	NO	5/8 NC X 5/8 LG
	5-7/16 (Max.)	1-1/4 X 5/16	1-1/4 X 15/16	5/8 NC X 5/8 LG

BORE TOLERANCE NOMINAL + .002 (MODELS 1805 THRU 6005)
BORE TOLERANCE NOMINAL + .0025 (MODELS GW7005 THRU GW10005)



MODELS

1806, 2106, 2406, 2606, 3206, 3806

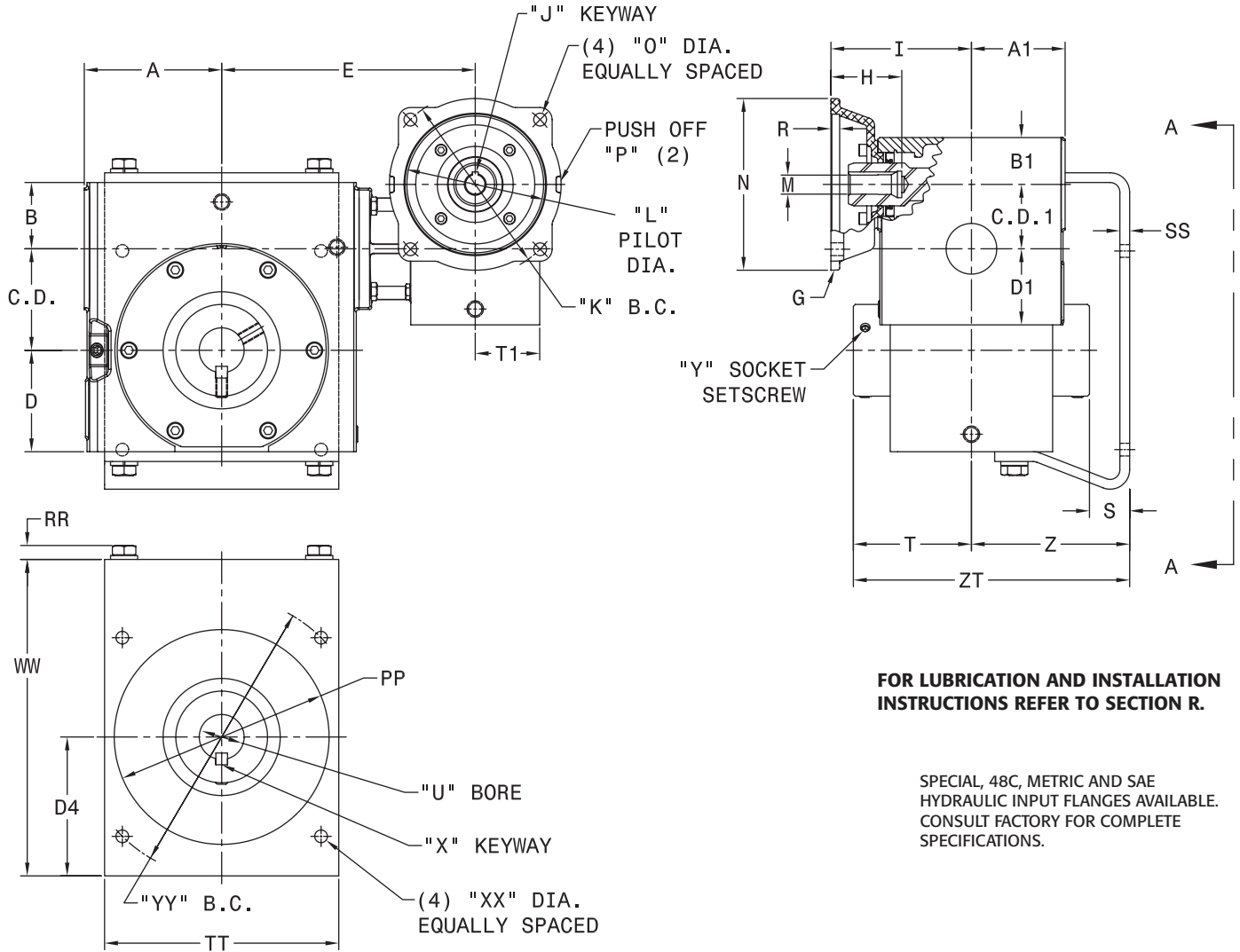

FOR LUBRICATION AND INSTALLATION INSTRUCTIONS REFER TO SECTION R.

SPECIAL, 48C, METRIC AND SAE HYDRAULIC INPUT FLANGES AVAILABLE. CONSULT FACTORY FOR COMPLETE SPECIFICATIONS.

DIMENSIONS SHOWN ARE FOR REFERENCE ONLY. DOWNLOAD AVAILABLE CAD MODELS AT: WWW.HUBCITYINC.COM

STANDARD STYLES AVAILABLE

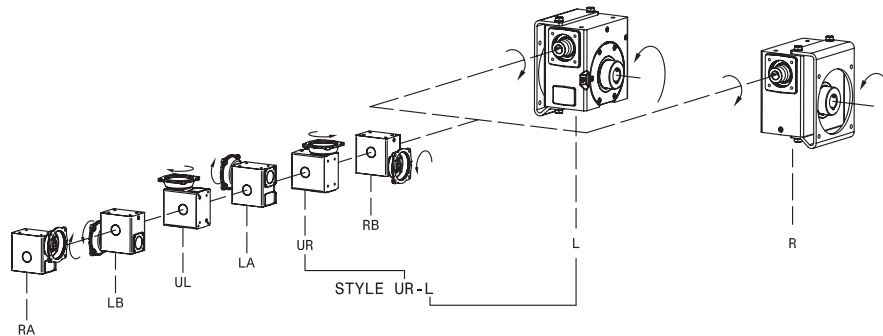

CONSULT FACTORY FOR VERTICAL SHAFT LUBRICATION RECOMMENDATIONS
INPUT SHAFT CAN BE ROTATED IN EITHER DIRECTION



MODELS

1806, 2106, 2406, 2606, 3206, 3806

B

MODEL	PRIMARY	SECONDARY	C.D.	C.D.1	A	A1	B	B1	D	D1	E	WT. LBS.
1806	134	186-56C	1.751	1.334	2.65	2.28	1.374	1.186	1.875	1.562	5.44	29
2106	134	216-56C	2.064	1.334	3.00	2.28	1.500	1.186	2.437	1.562	5.87	41
2406	134	246-56C	2.376	1.334	3.38	2.28	2.062	1.186	2.500	1.562	6.25	50
2606	134	266-56C	2.626	1.334	3.66	2.28	1.874	1.186	2.938	1.562	6.53	54
3206	214	326-143TC	3.251	2.064	4.40	3.00	2.124	1.500	3.250	2.437	8.12	99
3806	214	386-143TC	3.751	2.064	4.90	3.00	2.374	1.500	3.937	2.437	8.62	117

MODEL	G	H	I	J	K	L	M	N	O	P	R
1806	56C	2.27	3.63	3/16 X 3/32	5.875	4.501/4.503	.625	5.50	13/32	SLOTS	.19
2106	56C	2.27	3.63	3/16 X 3/32	5.875	4.501/4.503	.625	5.50	13/32	SLOTS	.19
2406	56C	2.27	3.63	3/16 X 3/32	5.875	4.501/4.503	.625	5.50	13/32	SLOTS	.19
2606	56C	2.27	3.63	3/16 X 3/32	5.875	4.501/4.503	.625	5.50	13/32	SLOTS	.19
3206	56C	2.27	4.50	3/16 X 3/32	5.875	4.501/4.503	.625	5.50	13/32	SLOTS	.19
	143TC	2.38					.875				
3806	56C	2.27	4.50	3/16 X 3/32	5.875	4.501/4.503	.625	5.50	13/32	SLOTS	.19
	143TC	2.38					.875				

MODEL	D4	S	T	TI	Z	PP	RR	SS	TT	WW	XX	YY	ZT
1806	3.13	.91	2.41	1.56	3.31	4.25	.22	.25	4.88	6.50	11/32	5.875	5.71
2106	3.75	.85	2.78	1.56	3.63	4.75	.33	.31	5.75	7.63	13/32	7.000	6.41
2406	3.61	.75	2.97	1.56	3.72	5.00	.33	.25	6.00	8.30	13/32	7.500	6.69
2606	3.89	.66	2.97	1.56	3.63	5.75	.33	.31	6.75	8.70	13/32	8.000	6.60
3206	4.45	.22	3.78	2.06	4.00	6.88	.44	.31	7.50	10.14	13/32	9.000	7.78
3806	5.09	.72	3.78	2.06	4.50	7.50	.44	.31	8.25	11.53	9/16	10.000	8.28

DOUBLE REDUCTION

STOCK BORES

MODEL	U	X	KEY FURNISHED	Y
1806	15/16	1/4 X 1/8	1/4 Sq.	10-24 NC X 1/4 LG
	1 (Max.)	1/4 X 1/8	1/4 Sq.	10-24 NC X 1/4 LG
2106	15/16	1/4 X 1/8	1/4 Sq.	5/16 NC X 5/16 LG
	1	1/4 X 1/8	1/4 Sq.	5/16 NC X 5/16 LG
	1-3/16	1/4 X 1/8	1/4 Sq.	5/16 NC X 5/16 LG
	1-1/4 (Max.)	1/4 X 1/8	1/4 Sq.	1/4 NC X 1/4 LG
2406 & 2606	1	1/4 X 1/8	1/4 Sq.	5/16 NC X 5/16 LG
	1-3/16	1/4 X 1/8	1/4 Sq.	5/16 NC X 5/16 LG
	1-1/4	1/4 X 1/8	1/4 Sq.	5/16 NC X 5/16 LG
	1-7/16 (Max.)	3/8 X 1/8	3/8 X 5/16	1/4 NC X 1/4 LG
3206 & 3806	1-7/16	3/8 X 3/16	3/8 Sq.	3/8 NC X 5/8 LG
	1-15/16	1/2 X 1/4	1/2 Sq.	3/8 NC X 3/8 LG
	2	1/2 X 1/4	1/2 Sq.	3/8 NC X 3/8 LG
	2-3/16 (Max.)	1/2 X 1/8	1/2 Sq.	3/8 NC X 3/8 LG

BORE TOLERANCE NOMINAL + .002



MODELS

4506, 5206

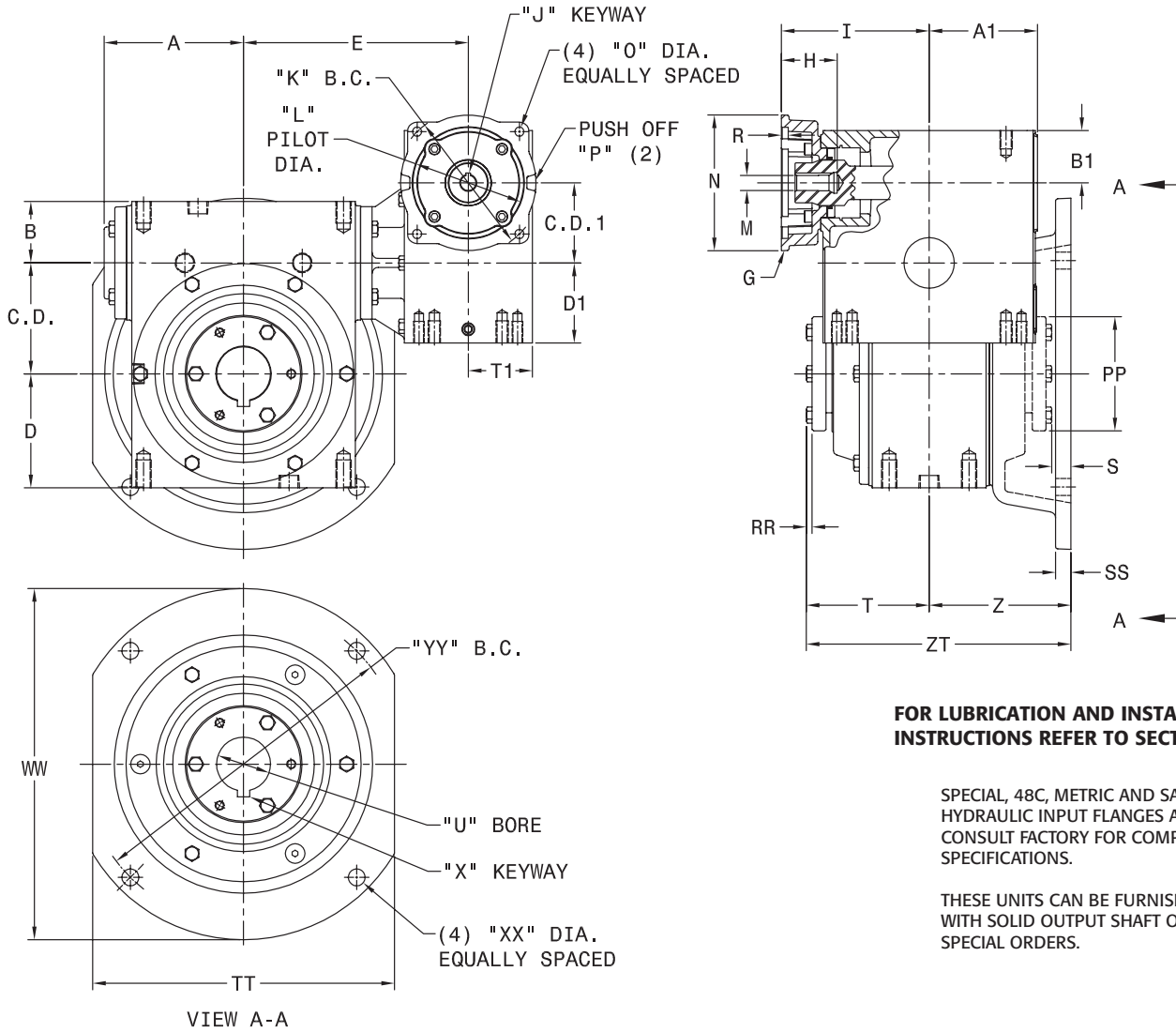

FOR LUBRICATION AND INSTALLATION INSTRUCTIONS REFER TO SECTION R.

SPECIAL, 48C, METRIC AND SAE HYDRAULIC INPUT FLANGES AVAILABLE. CONSULT FACTORY FOR COMPLETE SPECIFICATIONS.

THESE UNITS CAN BE FURNISHED WITH SOLID OUTPUT SHAFT ON SPECIAL ORDERS.

STANDARD STYLES AVAILABLE

DIMENSIONS SHOWN ARE FOR REFERENCE ONLY. DOWNLOAD AVAILABLE CAD MODELS AT: WWW.HUBCITYINC.COM

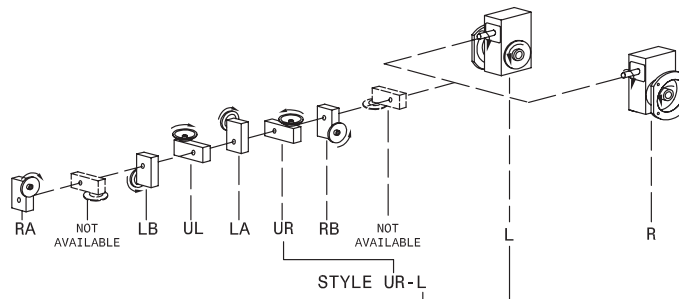

CONSULT FACTORY FOR VERTICAL SHAFT LUBRICATION RECOMMENDATIONS
INPUT SHAFT CAN BE ROTATED IN EITHER DIRECTION



MODELS

4506, 5206

B

SECONDARY UNIT DIMENSIONS

MODEL	PRIMARY	SECONDARY	C.D.	A	B	D	E	S	T	Z
4506	324	456-213TC	4.501	5.67	2.499	4.625	9.13	.75	5.00	5.75
5206	324	526-213TC	5.168	6.42	2.624	5.375	9.88	1.44	5.56	7.00

MODEL	SS	TT	WW	XX	YY	ZT	WT. LBS.
4506	.63	12.25	14.25	11/16	13.00	10.75	189
5206	.75	12.50	15.50	11/16	14.00	12.56	218

PRIMARY UNIT DIMENSIONS

MODEL	G	H	I	J	K	L	M	N	O	P	R	C.D.1	A1	B1	D1	T1
4506	56C	2.27	6.00	3/16 X 3/32	5.875	4.501/4.503	.625	5.50	13/32	SLOTS	.19	3.251	4.40	2.124	3.250	2.60
	143TC	2.38					.875									
	182TC	3.19					6.38									
5206	56C	2.27	6.00	3/16 X 3/32	5.875	4.501/4.503	.625	5.50	13/32	SLOTS	.19	3.251	4.40	2.124	3.250	2.60
	143TC	2.38					.875									
	182TC	3.19					6.38									

DOUBLE REDUCTION

QD BUSHING BORES

MODEL	U	X	PP	RR	KEY	TYPE	KIT*
4506	1-15/16	1/2 X 1/4	4-5/8	3/8	1/2 Sq.	SF	0229-02683
	2						0229-02684
	2-3/16						0229-02685
	2-7/16	5/8 X 3/16			5/8 x 1/2		0229-02686
	2-15/16	3/4 X 1/32			3/4 x 13/32		0229-02687
5206	2-3/16	1/2 X 1/4	6	7/16	1/2 Sq.	E	0229-02688
	2-7/16	5/8 X 3/16			5/8 Sq.		0229-02689
	2-15/16	3/4 X 1/8			3/4 X 1/2		0229-02690
	3						0229-02691
	3-3/16						0229-02692
	3-7/16						7/8 X 1/16

* ORDER BY QD BUSHING KIT NUMBER. BUSHING KITS ARE NOT INCLUDED IN REDUCER PRICE. KIT INCLUDES TWO BUSHINGS WITH KEYWAYS AND ONE KEY.

BORE TOLERANCE NOMINAL +.002



MODELS

3207, 3807, 4507, 5207, GW6007, GW7007, GW8007, GW10007

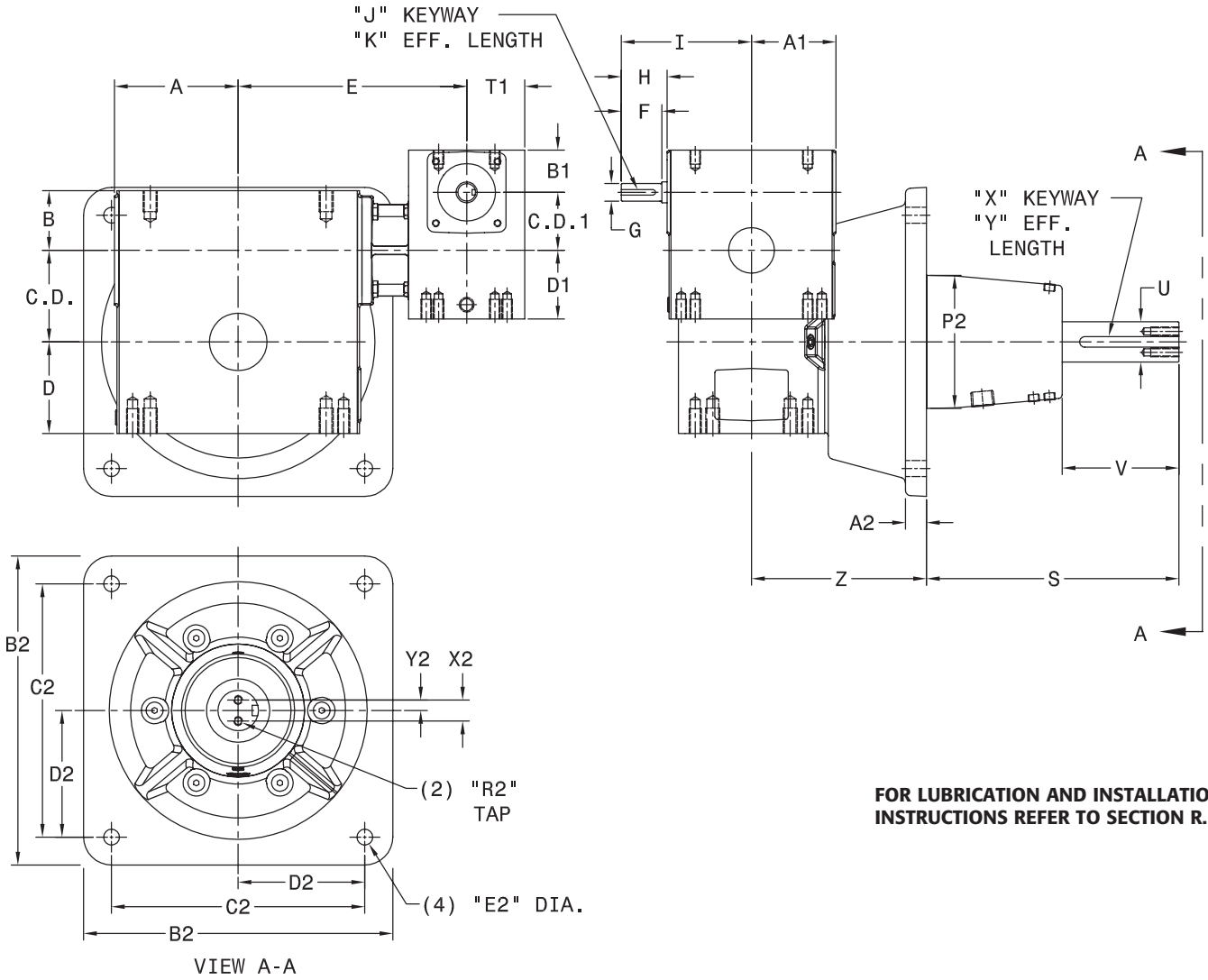

FOR LUBRICATION AND INSTALLATION INSTRUCTIONS REFER TO SECTION R.

STANDARD STYLES AVAILABLE

DIMENSIONS SHOWN ARE FOR REFERENCE ONLY.
 DOWNLOAD AVAILABLE CAD MODELS AT:
WWW.HUBCITYINC.COM

NOTE: STYLES DL-L AND DR-R ARE NOT AVAILABLE DUE TO INTERFERENCE BETWEEN PRIMARY UNIT AND SECONDARY DROP BEARING FLANGE.

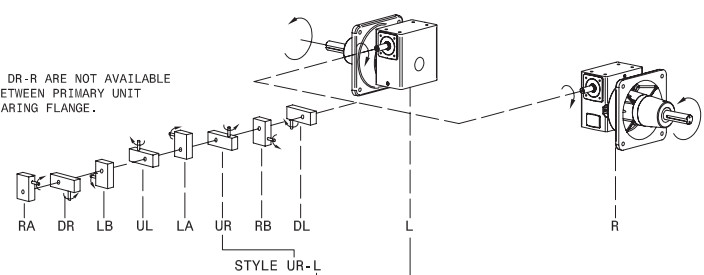

CONSULT FACTORY FOR VERTICAL SHAFT LUBRICATION RECOMMENDATIONS
 INPUT SHAFT CAN BE ROTATED IN EITHER DIRECTION



MODELS

3207, 3807, 4507, 5207, GW6007, GW7007, GW8007, GW10007

B

MODEL	PRIMARY	SECONDARY	C.D.	C.D.1	A	A1	B	B1	D	D1	E	F
3207	211	328-143TC	3.251	2.064	4.40	3.00	2.124	1.500	3.250	2.437	8.12	1.44
3807	211	388-143TC	3.751	2.064	4.90	3.00	2.374	1.500	3.937	2.437	8.62	1.44
4507	321	458-213TC	4.501	3.251	5.67	4.40	2.499	2.124	4.625	3.250	9.13	2.23
5207	321	528-213TC	5.168	3.251	6.42	4.40	2.624	2.124	5.375	3.250	9.88	2.23
GW6007	CUSTOM	GW607	6.000	3.251	10.24	5.02	4.00	2.63	6.50	3.50	13.30	2.35
GW7007	CUSTOM	GW707	7.000	3.251	10.63	5.02	4.32	2.63	7.59	3.50	12.96	2.35
GW8007	CUSTOM	GW807	8.000	4.251	11.93	6.10	4.10	2.69	8.86	4.44	13.94	3.57
GW10007	CUSTOM	GW1007	10.000	5.251	14.34	7.50	5.11	3.63	10.36	5.12	17.05	3.40

MODEL	G	H	I	J	K	T1	WT. LBS.
3207	.625/.624	1.63	4.63	3/16 X 3/32	1.13	2.06	130
3807	.625/.624	1.63	4.63	3/16 X 3/32	1.13	2.06	159
4507	.875/.874	2.48	6.88	3/16 X 3/32	1.91	2.60	246
5207	.875/.874	2.48	6.88	3/16 X 3/32	1.91	2.60	294
GW6007	.875	2.38	6.76	3/16 X 3/32	1.75	3.40	444
GW7007	.875	2.38	6.76	3/16 X 3/32	1.75	3.40	643
GW8007	1.250	3.47	9.57	1/4 X 1/8	2.88	3.62	920
GW10007	1.250	3.38	10.88	1/4 X 1/8	3.00	4.28	1406

MODEL	OUTPUT FLANGE	S	U	V	X	Y	Z
3207	STD	9.50	1.4375/1.4365	4.68	3/8 X 3/16	3.87	6.22
	LARGE*	9.50	1.625/1.624	4.63	3/8 X 3/16	3.69	6.37
3807	STD	9.50	1.625/1.624	4.63	3/8 X 3/16	3.69	6.58
4507	STD	10.50	1.6875/1.6865	5.50	3/8 X 3/16	4.69	6.00
5207	STD	10.50	2.1875/2.1865	5.53	1/2 X 1/4	4.63	6.25
GW6007	STD	15.50	2.438	7.63	5/8 X 5/16	6.50	7.00
GW7007	STD	15.50	2.937	7.63	3/4 X 3/8	6.44	8.50
GW8007	STD	17.06	3.438	9.25	7/8 X 7/16	8.00	10.00
GW10007	STD	17.00	3.938	9.43	1 X 1/2	7.75	12.50

* LARGE FLANGE AVAILABLE AS MODIFIED STANDARD. CONSULT FACTORY.

MODEL	OUTPUT FLANGE	A2	B2	C2	D2	E2	P2	R2	X2	Y2
3207	STD	.75	11.00	9.000	4.500	9/16	4.75	5/16 NC X 1.00 DP	.75	.38
	LARGE*	.94	12.50	10.500	5.250	9/16	4.94	5/16 NC X 1.00 DP	.75	.38
3807	STD	.94	12.50	10.500	5.250	9/16	4.94	5/16 NC X 1.00 DP	.75	.38
4507	STD	.81	14.00	12.000	6.000	11/16	5.50	3/8 NC X 1.00 DP	1.00	.50
5207	STD	.84	16.00	14.000	7.000	13/16	6.63	3/8 NC X 1.00 DP	1.50	.75
GW6007	STD	1.50	19.50	17.000	8.500	15/16	9.50	3/8 NC X 1.00 DP	1.50	.75
GW7007	STD	1.75	22.00	19.000	9.500	1-1/8	10.75	3/8 NC X 1.00 DP	2.00	1.00
GW8007	STD	2.00	28.00	24.000	12.000	1-5/16	13.75	5/8 NC X 1.50 DP	2.12	1.06
GW10007	STD	2.25	32.00	28.000	14.000	1-5/16	17.00	5/8 NC X 1.50 DP	2.38	1.19

* LARGE FLANGE AVAILABLE AS MODIFIED STANDARD. CONSULT FACTORY.

DOUBLE REDUCTION



MODELS

3208, 3808, 4508, 5208, GW6008, GW7008, GW8008, GW10008

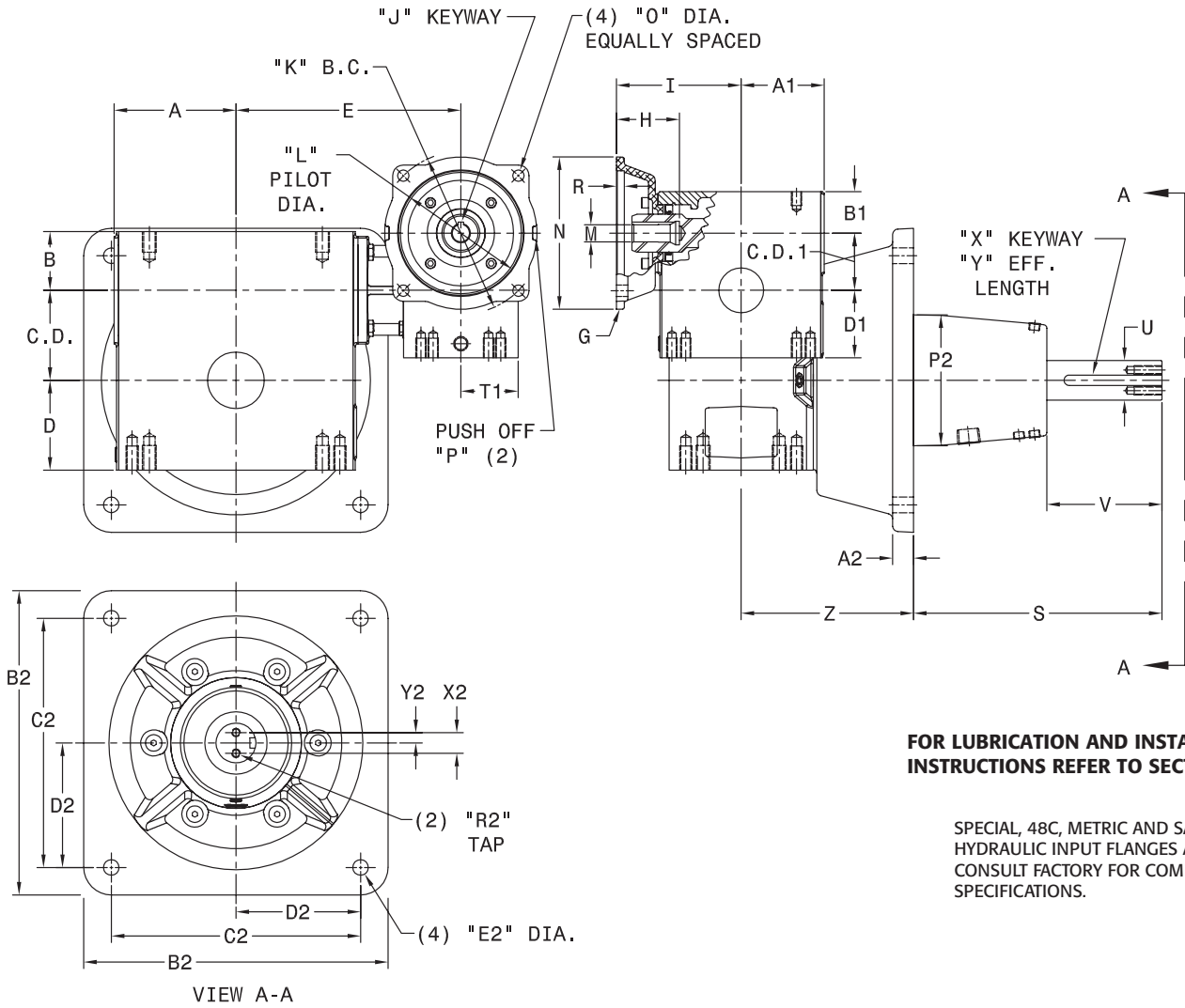

FOR LUBRICATION AND INSTALLATION INSTRUCTIONS REFER TO SECTION R.

SPECIAL, 48C, METRIC AND SAE HYDRAULIC INPUT FLANGES AVAILABLE. CONSULT FACTORY FOR COMPLETE SPECIFICATIONS.

STANDARD STYLES AVAILABLE

DIMENSIONS SHOWN ARE FOR REFERENCE ONLY. DOWNLOAD AVAILABLE CAD MODELS AT: WWW.HUBCITYINC.COM

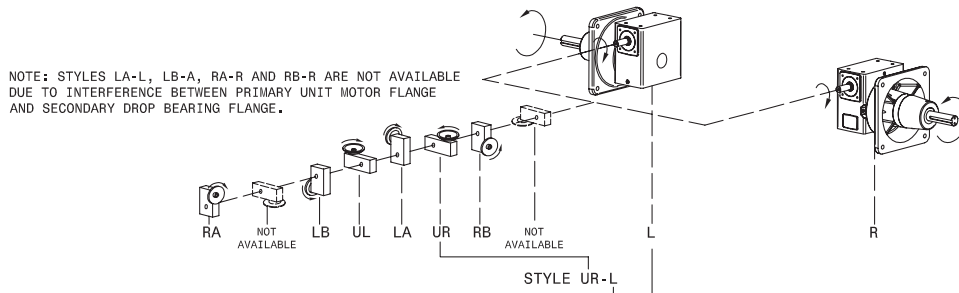

CONSULT FACTORY FOR VERTICAL SHAFT LUBRICATION RECOMMENDATIONS
INPUT SHAFT CAN BE ROTATED IN EITHER DIRECTION



MODELS

3208, 3808, 4508, 5208, GW6008, GW7008, GW8008, GW10008

B

SECONDARY UNIT DIMENSIONS

MODEL	PRIMARY	SECONDARY	C.D.	A	B	D	E	OUTPUT FLANGE	S	U	V	X	Y	Z
3208	214	328-143TC	3.251	4.40	2.124	3.250	8.12	STD	9.50	1.4375/1.4365	4.68	3/8 X 3/16	3.87	6.22
								LARGE*	9.50	1.625/1.624	4.63	3/8 X 3/16	3.69	6.37
3808	214	388-143TC	3.751	4.90	2.374	3.937	8.62	STD	9.50	1.625/1.624	4.63	3/8 X 3/16	3.69	6.58
4508	324	458-213TC	4.501	5.67	2.499	4.625	9.13	STD	10.50	1.6875/1.6865	5.50	3/8 X 3/16	4.69	6.00
5208	324	528-213TC	5.168	6.42	2.624	5.375	9.88	STD	10.50	2.1875/2.1865	5.53	1/2 X 1/4	4.63	6.25
GW6008	CUSTOM	GW607	6.000	10.24	4.00	6.50	13.30	STD	15.50	2.438	7.63	5/8 X 5/16	6.50	7.00
GW7008	CUSTOM	GW707	7.000	10.63	4.32	7.59	12.96	STD	15.50	2.937	7.63	3/4 X 3/8	6.44	8.50
GW8008	CUSTOM	GW807	8.000	11.93	4.10	8.86	13.94	STD	17.06	3.438	9.25	7/8 X 7/16	8.00	10.00
GW10008	CUSTOM	GW1007	10.000	14.34	5.11	10.36	17.05	STD	17.00	3.938	9.43	1 X 1/2	7.75	12.50

* LARGE FLANGE AVAILABLE AS MODIFIED STANDARD. CONSULT FACTORY.

MODEL	OUTPUT FLANGE	A2	B2	C2	D2	E2	P2	R2	X2	Y2	WEIGHT LBS.
3208	STD	.75	11.00	9.000	4.500	9/16	4.75	5/16 NC X 1.00 DP	.75	.38	132
	LARGE*	.94	12.50	10.500	5.250	9/16	4.94	5/16 NC X 1.00 DP	.75	.38	
3808	STD	.94	12.50	10.500	5.250	9/16	4.94	5/16 NC X 1.00 DP	.75	.38	161
4508	STD	.81	14.00	12.000	6.000	11/16	5.50	3/8 NC X 1.00 DP	1.00	.50	250
5208	STD	.84	16.00	14.000	7.000	13/16	6.63	3/8 NC X 1.00 DP	1.50	.75	298
GW6008	STD	1.50	19.50	17.000	8.500	15/16	9.50	3/8 NC X 1.00 DP	1.50	.75	448
GW7008	STD	1.75	22.00	19.000	9.500	1-1/8	10.75	3/8 NC X 1.00 DP	2.00	1.00	647
GW8008	STD	2.00	28.00	24.000	12.000	1-5/16	13.75	5/8 NC X 1.50 DP	2.12	1.06	930
GW10008	STD	2.25	32.00	28.000	14.000	1-5/16	17.00	5/8 NC X 1.50 DP	2.38	1.19	1431

* LARGE FLANGE AVAILABLE AS MODIFIED STANDARD. CONSULT FACTORY.

PRIMARY UNIT DIMENSIONS

MODEL	G	H	I	J	K	L	M	N	O	P	R	C.D.1	A1	B1	D1	T1
3208	56C	2.27	4.50	3/16 X 3/32	5.875	4.501/4.503	.625	5.50	13/32	SLOTS	.19	2.064	3.00	1.500	2.437	2.06
	143TC	2.38					.875									
3808	56C	2.27	4.50	3/16 X 3/32	5.875	4.501/4.503	.625	5.50	13/32	SLOTS	.19	2.064	3.00	1.500	2.437	2.06
	143TC	2.38					.875									
4508	56C	2.27	6.00	3/16 X 3/32	5.875	4.501/4.503	.625	5.50	13/32	SLOTS	.19	3.251	4.40	2.124	3.250	2.60
	143TC	2.38					.875									
	182TC	3.19					6.38									
5208	56C	2.27	6.00	3/16 X 3/32	5.875	4.501/4.503	.625	5.50	13/32	SLOTS	.19	3.251	4.40	2.124	3.250	2.60
	143TC	2.38					.875									
	182TC	3.19					6.38									
GW6008	56C	2.33	5.88	3/16 X 3/32	5.875	4.501/4.503	.625	5.88	13/32	N/A	.19	3.251	5.02	2.63	3.50	3.40
	143TC						.875									
	182TC	2.94	6.50	1/4 X 1/8	7.250	8.501/8.504	1.125	9.00	17/32	N/A	.19					
	213TC	3.10	6.94	5/16 X 5/32			1.375									
GW7008	56C	2.33	5.88	3/16 X 3/32	5.875	4.501/4.503	.625	5.88	13/32	N/A	.19	3.251	5.02	2.63	3.50	3.40
	143TC						.875									
	182TC	2.94	6.50	1/4 X 1/8	7.250	8.501/8.504	1.125	9.00	17/32	N/A	.19					
	213TC	3.10	6.94	5/16 X 5/32			1.375									
GW8008	56C	2.33	6.45	3/16 X 3/32	5.875	4.501/4.503	.625	5.88	13/32	N/A	.19	4.251	6.10	2.69	4.44	3.62
	143TC						.875									
	182TC	3.44	7.40	1/4 X 1/8	7.250	8.501/8.504	1.125	9.00	17/32	N/A	.19					
	213TC			5/16 X 5/32			1.375									
GW10008	56C	2.44	7.85	3/16 X 3/32	5.875	4.501/4.503	.625	5.88	13/32	N/A	.19	5.251	7.50	3.63	5.12	4.28
	143TC						.875									
	182TC	3.44	8.80	1/4 X 1/8	7.250	8.501/8.504	1.125	9.00	17/32	N/A	.19					
	213TC			5/16 X 5/32			1.375									
	256TC	4.00	9.36	3/8 X 3/16			1.625									

DOUBLE REDUCTION



MODELS

4509, 5209

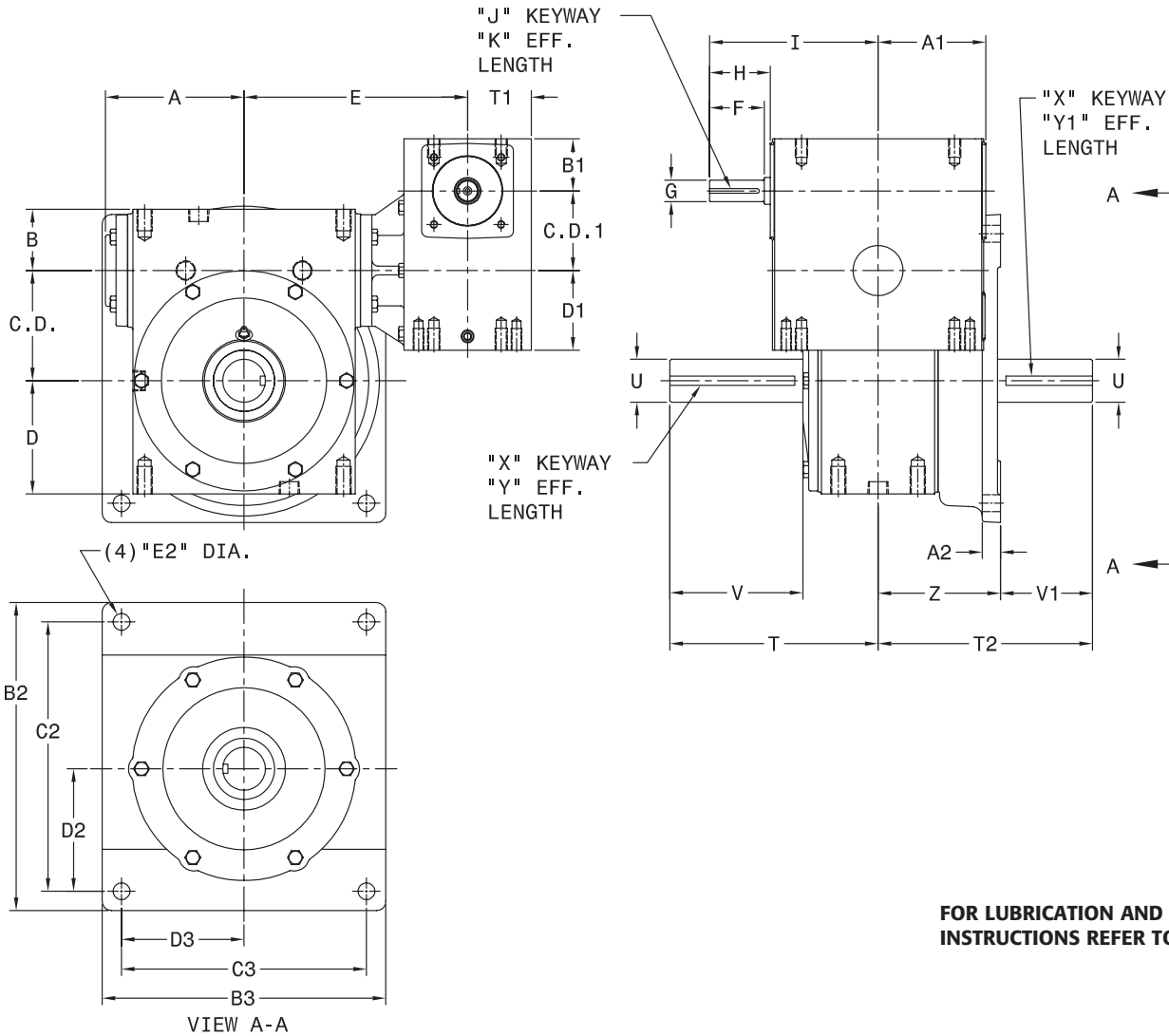

FOR LUBRICATION AND INSTALLATION INSTRUCTIONS REFER TO SECTION R.

STANDARD STYLES AVAILABLE

DIMENSIONS SHOWN ARE FOR REFERENCE ONLY.
DOWNLOAD AVAILABLE CAD MODELS AT:
WWW.HUBCITYINC.COM

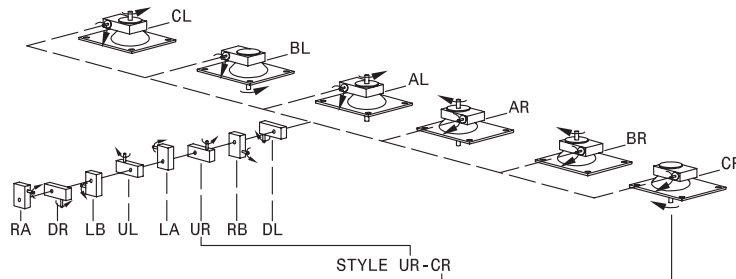

CONSULT FACTORY FOR VERTICAL SHAFT LUBRICATION RECOMMENDATIONS
INPUT SHAFT CAN BE ROTATED IN EITHER DIRECTION



MODELS

4509, 5209

B

MODEL	PRIMARY	SECONDARY	C.D.	C.D.1	A	A1	B	B1	D	D1
4509	321	450V-213TC	4.501	3.251	5.67	4.40	2.499	2.124	4.625	3.250
5209	321	520V-213TC	5.168	3.251	6.42	4.40	2.624	2.124	5.375	3.250

MODEL	E	F	G	H	I	J	K	T1
4509	9.13	2.23	.875/.874	2.48	6.88	3/16 X 3/32	1.91	2.60
5209	9.88	2.23	.875/.874	2.48	6.88	3/16 X 3/32	1.91	2.60

MODEL	T	T2	U	V	V1	X	Y	Y1	Z
4509	8.50	8.75	1.750/1.749	5.43	3.75	3/8 X 3/16	4.59	3.03	5.00
5209	9.00	9.75	2.000/1.999	5.66	4.25	1/2 X 1/4	4.88	3.50	5.50

MODEL	A2	B2	B3	C2	C3	D2	D3	E2	WT. LBS.
4509	8.50	8.75	1.750/1.749	5.43	3.75	3/8 X 3/16	4.59	3.03	5.00
5209	9.00	9.75	2.000/1.999	5.66	4.25	1/2 X 1/4	4.88	3.50	5.50

DOUBLE REDUCTION

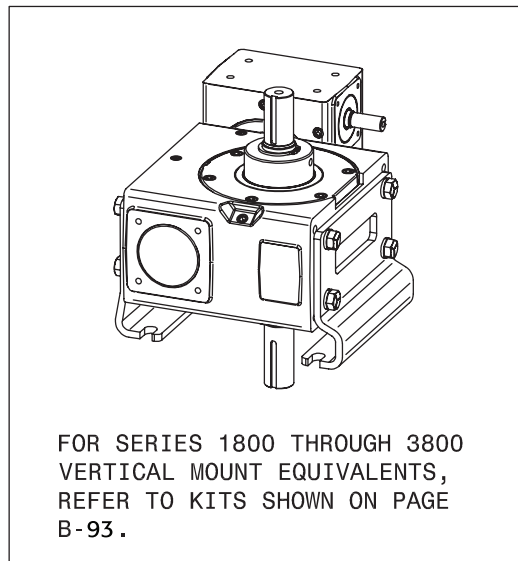



MODELS

4510, 5210

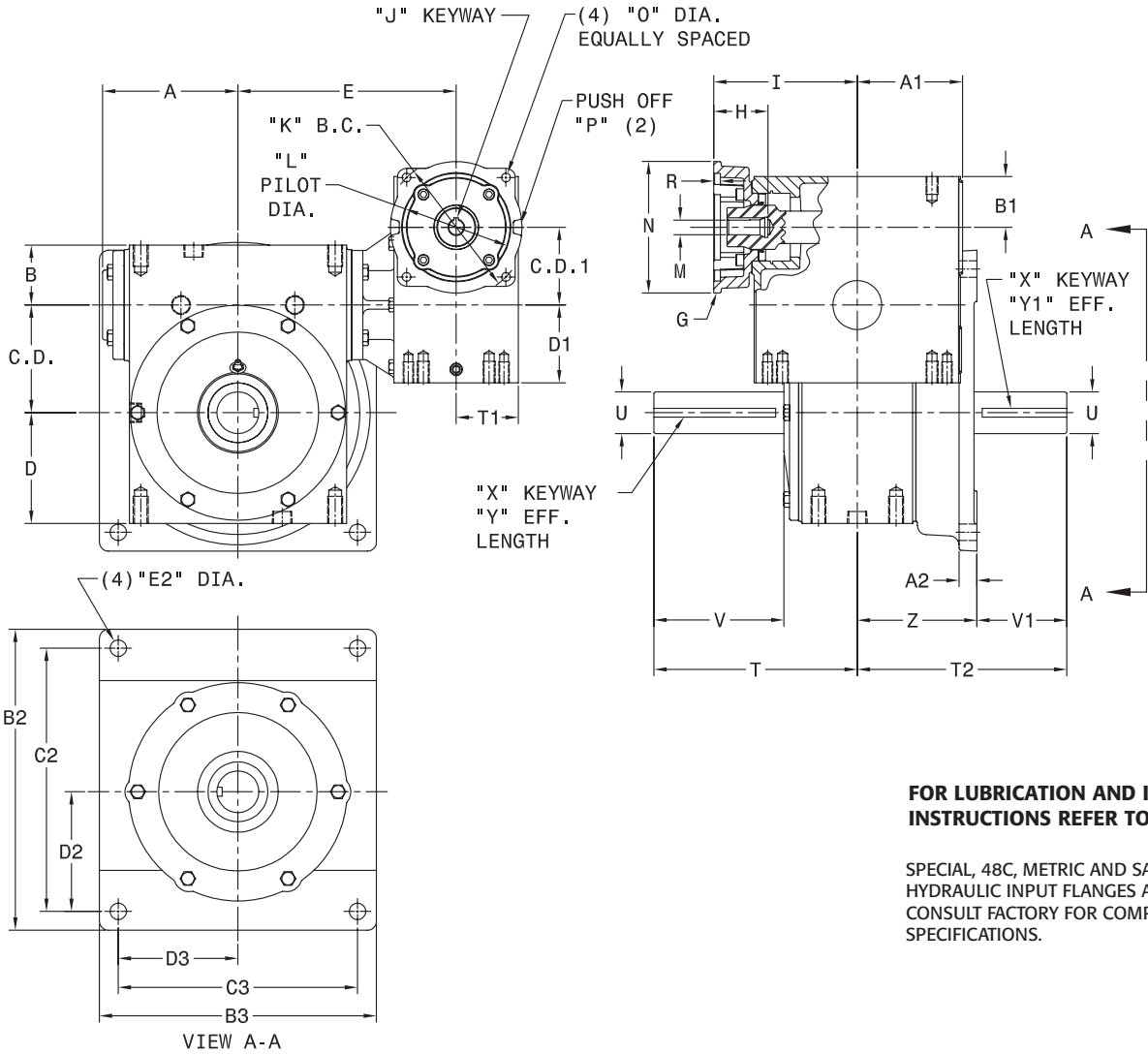

FOR LUBRICATION AND INSTALLATION INSTRUCTIONS REFER TO SECTION R.

SPECIAL, 48C, METRIC AND SAE HYDRAULIC INPUT FLANGES AVAILABLE. CONSULT FACTORY FOR COMPLETE SPECIFICATIONS.

STANDARD STYLES AVAILABLE

DIMENSIONS SHOWN ARE FOR REFERENCE ONLY. DOWNLOAD AVAILABLE CAD MODELS AT: WWW.HUBCITYINC.COM

PRIMARY STYLES LB & LA NOT AVAILABLE WITH SECONDARY STYLES AR, BR, OR CR.
 PRIMARY STYLES RA & RB NOT AVAILABLE WITH SECONDARY STYLES AL, BL, OR CL.

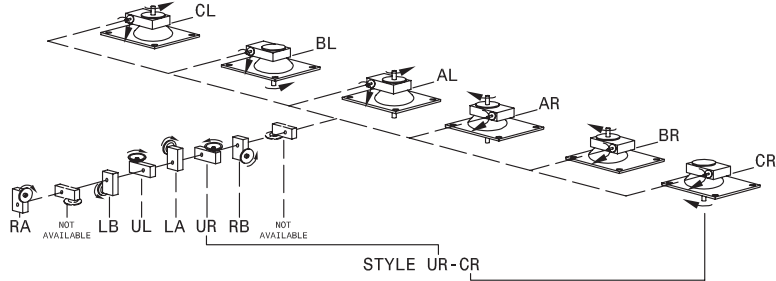

CONSULT FACTORY FOR VERTICAL SHAFT LUBRICATION RECOMMENDATIONS
 INPUT SHAFT CAN BE ROTATED IN EITHER DIRECTION



MODELS

4510, 5210

B

SECONDARY UNIT DIMENSIONS

MODEL	PRIMARY	SECONDARY	C.D.	A	B	D	E	T	T2	U	V	V1
4510	321	450V-213TC	4.501	5.67	2.499	4.625	9.13	8.50	8.75	1.750/1.749	5.43	3.75
5210	321	520V-213TC	5.168	6.42	2.624	5.375	9.88	9.00	9.75	2.000/1.999	5.66	4.25

MODEL	X	Y	Y1	Z	A2	B2	B3	C2	C3	D2	D3	E2	WT. LBS.
4510	3/8 X 3/16	4.59	3.03	5.00	.75	12.58	11.58	11.000	10.000	5.000	5.000	11/16	189
5210	1/2 X 1/4	4.88	3.50	5.50	.75	16.83	12.58	15.250	11.000	6.750	5.500	11/16	218

PRIMARY UNIT DIMENSIONS

MODEL	G	H	I	J	K	L	M	N	O	P	R	C.D.1	A1	B1	D1	T1
4510	56C	2.27	6.00	3/16 X 3/32	5.875	4.501/4.503	.625	5.50	13/32	SLOTS	.19	3.251	4.40	2.124	3.250	2.60
	143TC	2.38					.875									
	182TC	3.19					6.38									
5210	56C	2.27	6.00	3/16 X 3/32	5.875	4.501/4.503	.625	5.50	13/32	SLOTS	.19	3.251	4.40	2.124	3.250	2.60
	143TC	2.38					.875									
	182TC	3.19					6.38									

DOUBLE REDUCTION

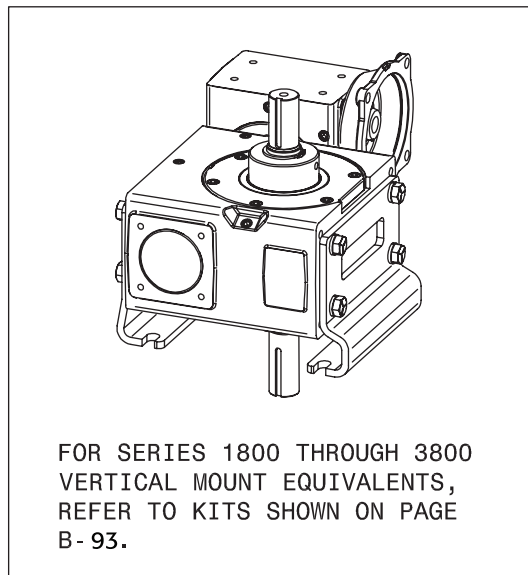



TRIPLE REDUCTION

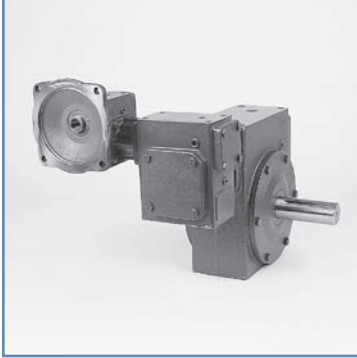

TRIPLE REDUCTION FEATURES

- Provides all the same basic features as the single and double reduction units with three Hub City gearboxes connected.
- Available in ratios from 1000:1 to 216,000:1
- Different models to choose from. Not shown in this catalog. See www.hubcityinc.com

FOR ADDITIONAL TRIPLE REDUCTION INFORMATION,

PLEASE GO TO OUR WEBSITE:

www.hubcityinc.com



ACCESSORIES & FACTORY OPTIONS

B

The following factory options are also available for gear drives in this catalog. Contact the factory for details on price, availability, and specifications.

CLEANLINE™

See Section O

Features

FDA approved white acrylic paint
Corrosion resistant shaft treatment or stainless steel shafts
Stainless steel hardware and nameplate

Options

Motorized versions
BISSC Standards

METRIC VERSIONS

Features

Metric Motor flanges
Metric shaft dimensions
Metric mounting dimensions

Options

Motorized versions
Modified and Custom Designs

MODIFIED AND CUSTOM DESIGNS

If you have looked through this catalog and do not see exactly what you need, Hub City has the capability and engineering expertise to design and produce a special drive. Capabilities range from flange and shaft modifications, to custom housing dimensions. Consult the factory or your Hub City representative with your specifications.

ACCESSORIES & OPTIONS



UNIVERSAL BASE KITS

C-FACE UNITS MOUNTED WITH WORM BOTTOM ARE NOT RECOMMENDED AND WILL NOT WORK WITH THESE BASE KITS. IF IT IS NECESSARY TO MOUNT THE UNIT IN THIS POSITION, USE THE ADJUSTABLE BASE KIT SHOWN ON PAGE B-89 OR CONSULT FACTORY FOR OTHER AVAILABLE MOUNTING FEET.

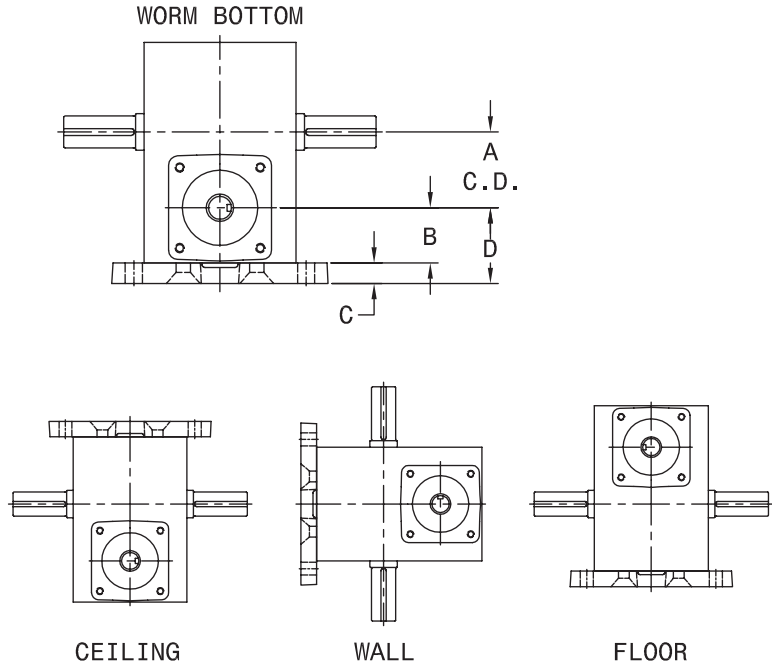
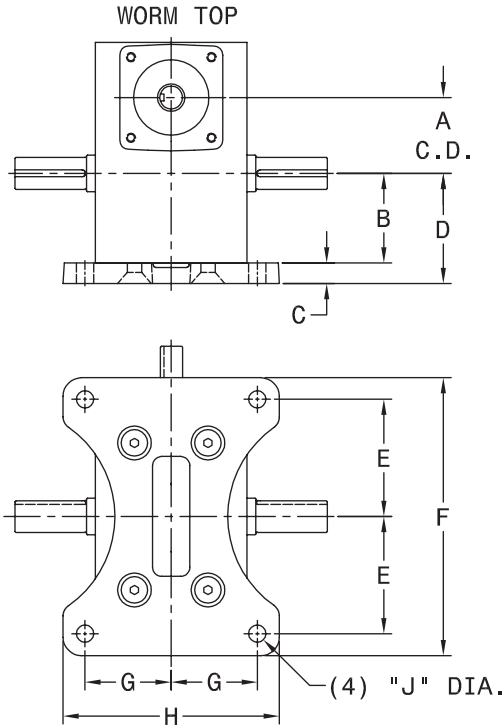

SERIES	KIT NUMBER	SHIPPING WT. LBS.		A	B	C	D	E	F	G	H	J
130	0229-01761	1.9	WORM TOP	1.334	1.562	.687	2.249	2-3/16	5-3/8	1-21/32	4-3/16	11/32
			WORM BOTTOM		1.186		3.207					
180	0229-01592	1.8	WORM TOP	1.751	1.875	.875	2.750	2-7/8	6-7/8	2-1/4	5-5/8	13/32
			WORM BOTTOM		1.374		4.000					
210	0229-01750	4.5	WORM TOP	2.064	2.437	.562	2.999	3-3/16	7-1/2	2-11/32	5-13/16	15/32
			WORM BOTTOM		1.500		4.125					
W240	0229-03062	6.0	WORM TOP	2.376	2.500	.750	3.250	3-17/32	8-3/8	2-7/16	6-3/16	15/32
			WORM BOTTOM		2.062		5.188					
260	0229-01785	7.7	WORM TOP	2.626	2.938	.750	3.688	4	9-1/2	2-5/8	6-3/4	17/32
			WORM BOTTOM		1.874		5.250					
320	0229-01925	9.0	WORM TOP	3.251	3.250	1.125	4.375	4-3/4	10-3/4	3-1/16	7-3/8	17/32
			WORM BOTTOM		2.124		6.500					
380	0229-02409	10.0	WORM TOP	3.751	3.937	.875	4.812	5-3/16	11-5/8	3-1/2	8-1/4	19/32
			WORM BOTTOM		2.374		7.000					
450	0229-02480	16.3	WORM TOP	4.501	4.625	1.000	5.625	6-1/16	13-3/8	3-13/16	8-7/8	21/32
			WORM BOTTOM		2.499		8.000					
520	0229-02484	17.8	WORM TOP	5.168	5.375	1.062	6.437	7-1/16	16	4-3/16	10-1/4	25/32
			WORM BOTTOM		2.624		8.854					
GW60	0279-00620	31	WORM TOP	6.000	6.500	1.250	7.750	8-1/4	19	4-3/4	12	29/32
			WORM BOTTOM		4.000		5.250					
GW70	0279-00600	41	WORM TOP	7.000	7.59	1.42	9.00	6-1/2	15-3/8	5-5/8	13-3/8	1-1/8
			WORM BOTTOM		4.32		12.75					
GW80	0279-00601	48	WORM TOP	8.000	8.86	1.65	10.50	7-3/8	17-3/8	5-3/4	13-1/2	1-1/8
			WORM BOTTOM		4.10		13.75					
GW100	0279-00602	76	WORM TOP	10.000	10.36	1.65	12.00	8-1/2	21-9/64	7	16-7/8	1-7/16
			WORM BOTTOM		5.11		16.76					



ADJUSTABLE BASE KITS

B

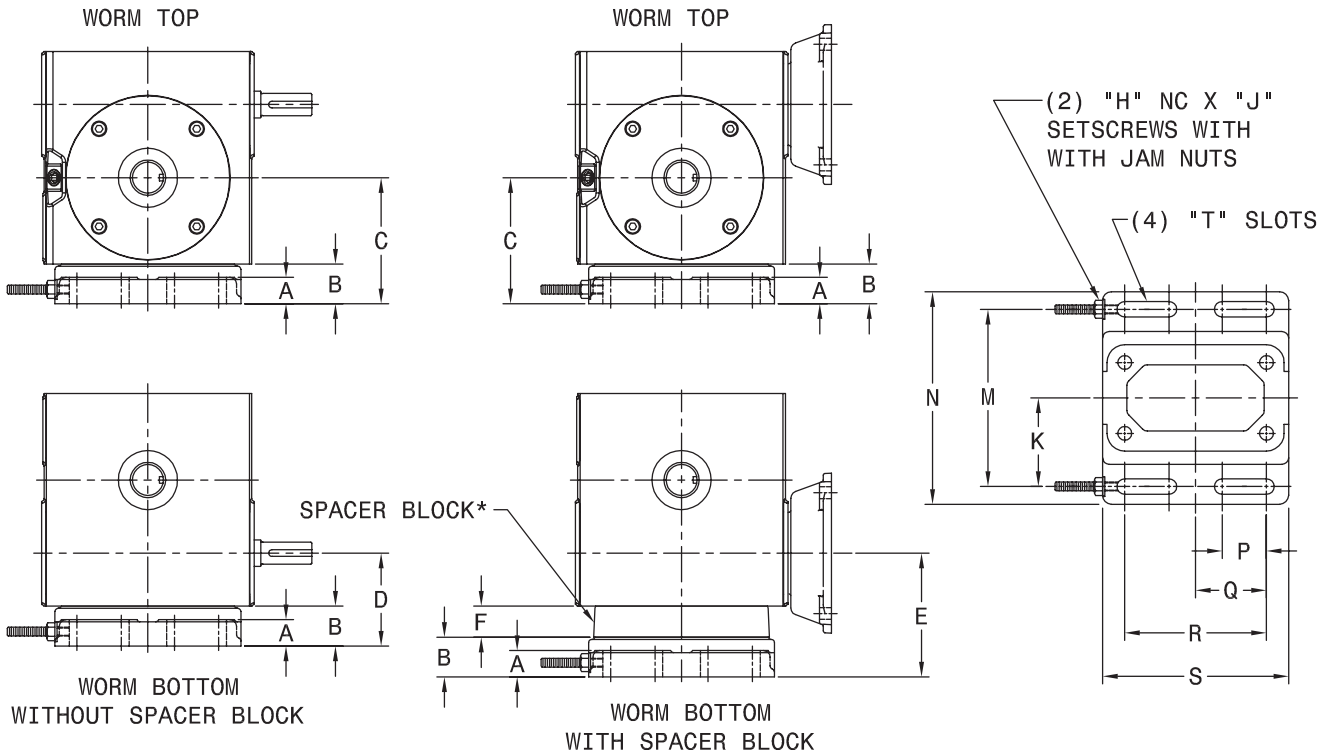

SERIES	ADJUSTABLE BASE KIT NUMBER	ADJUSTABLE BASE KIT SHIPPING WT.	SPACER BLOCK KIT NUMBER *	SPACER BLOCK KIT SHIPPING WT.	A	B	C	D	E
130	0229-00015	3.0 lbs.	0229-00023	3.0 lbs.	3/4	1-1/8	2-11/16	2-5/16	3-1/2
180	0229-00016	4.0 lbs.	0229-00024	3.0 lbs.	3/4	1-1/8	3	2-1/2	3-1/2
210	0229-00017	5.0 lbs.	0229-00025	3.0 lbs.	3/4	1-1/8	3-9/16	2-5/8	3-1/2
W240	0229-02988	8.0 lbs.	N/A	N/A	7/8	1-7/16	3-15/16	3-1/2	N/A
260	0229-00018	8.0 lbs.	N/A	N/A	7/8	1-5/8	4-9/16	3-1/2	N/A
320	0229-00019	10.0 lbs.	N/A	N/A	7/8	1-3/8	4-5/8	3-1/2	N/A
380	0229-00020	11.0 lbs.	N/A	N/A	7/8	1-3/8	5-5/16	3-3/4	N/A
450	0229-00021	15.0 lbs.	N/A	N/A	7/8	1-3/8	6	3-7/8	N/A
520	0229-00022	23.0 lbs.	N/A	N/A	1	1-1/2	6-7/8	4-1/8	N/A

* CONTACT FACTORY FOR SPACER BLOCK KIT AVAILABILITY.

SERIES	F	H	J	K	M	N	P	Q	R	S	T
130	1-3/16	1/4	1-1/4	2	4	4-3/4	3/4	1-3/16	2-3/8	3-3/8	5/16
180	1	1/4	1-1/2	2-1/8	4-1/4	5-1/4	1	1-9/16	3-1/8	4-1/4	5/16
210	7/8	1/4	1-3/4	2-1/2	5	6	1-1/4	2	4	5-1/4	7/16
W240	N/A	3/8	2-1/2	3	6	7-1/4	1-1/4	2-1/2	5	7	9/16
260	N/A	3/8	2	2-3/4	5-1/2	6-3/4	1-1/4	2-7/16	4-7/8	6-1/2	9/16
320	N/A	3/8	2	3	6	7-1/8	1-3/8	3-1/8	6-1/4	7-3/4	9/16
380	N/A	3/8	2	3-1/8	6-1/4	7-1/2	1-1/2	3-7/16	6-7/8	8-3/8	9/16
450	N/A	3/8	2-1/2	3-5/8	7-1/4	8-3/4	1-5/8	3-7/8	7-3/4	9-5/8	11/16
520	N/A	3/8	2-1/2	4-1/4	8-1/2	10	1-7/8	4-3/4	9-1/2	11-3/8	11/16

ACCESSORIES & OPTIONS



SIDE MOUNTING KITS

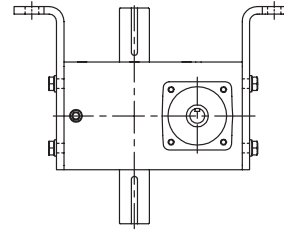
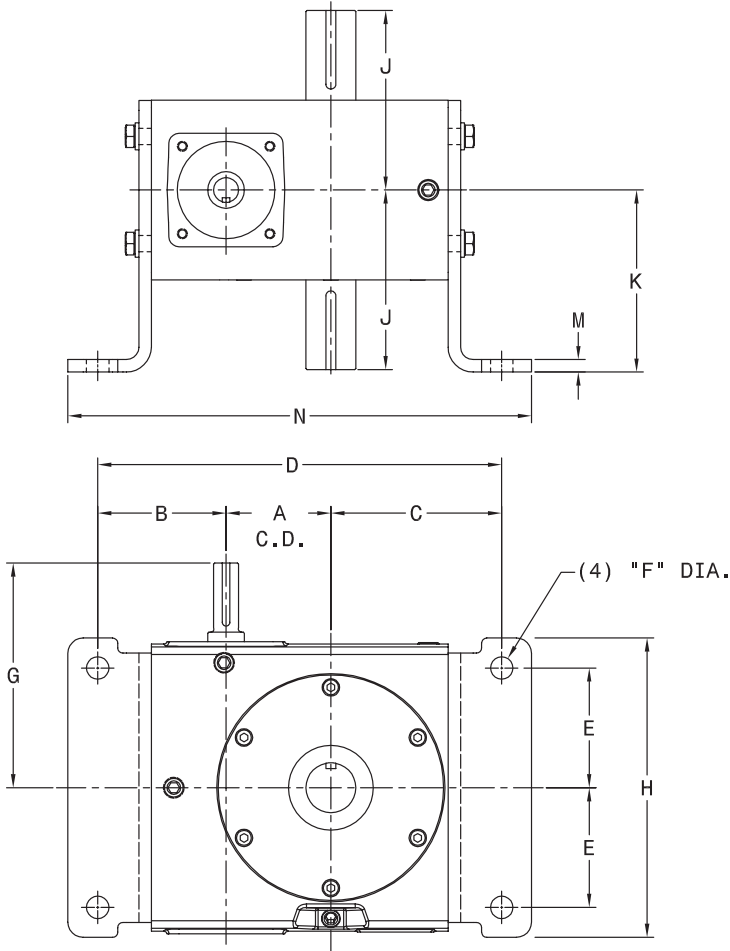

CEILING

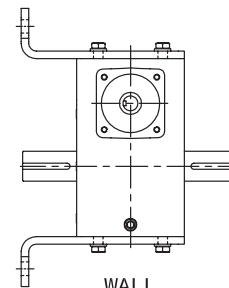

WALL

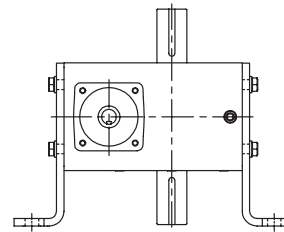

FLOOR

CONSULT FACTORY FOR VERTICAL SHAFT APPLICATIONS

SERIES	SIDE MTG KIT NUMBER	SIDE MTG KIT SHIPPING WT.	A C.D.	B	C	D	E	F	G	H	J	K	M	N	MATL*
130	0229-02989	3.2 lbs.	1.334	2.05	2.43	5.81	1.63	.31	3.82	4.00	3.25	3.312	.25	6.58	ST **
180	0229-02990	4.2 lbs.	1.751	2.37	2.88	7.00	2.13	.44	4.19	5.25	3.50	3.562	.25	8.00	ST **
210	0229-02991	9.3 lbs.	2.064	2.75	3.69	8.50	2.13	.44	4.63	5.75	4.25	4.375	.31	9.50	ST **
W240	0229-02992	9.6 lbs.	2.376	3.06	3.50	8.94	2.44	.44	5.00	6.00	4.50	4.562	.31	9.94	ST **
260	0229-02993	11.7 lbs.	2.626	3.22	4.28	10.12	3.00	.56	5.63	7.50	4.50	4.562	.31	11.62	ST **
320	0229-02994	14.0 lbs.	3.251	3.44	4.56	11.25	4.00	.56	6.88	9.25	5.44	5.50	.31	12.51	ST **
380	0229-02995	17.0 lbs.	3.751	3.87	5.44	13.06	4.25	.56	7.38	9.75	6.69	6.812	.31	14.32	ST **
450	0229-02497	34.1 lbs.	4.501	4.25	6.38	15.13	5.13	.66	8.44	11.50	7.25	7.375	.69	16.39	CI
520	0229-02498	43.5 lbs.	5.168	4.50	7.25	16.92	5.38	.66	9.25	12.00	7.81	7.937	.69	18.17	CI
GW60	0279-00621	36 lbs.	6.000	6.19	8.69	20.88	5.88	.91	11.78	14.75	10.00	7.31	.50	23.26	ST
GW70	0279-00603	71 lbs.	7.000	6.87	10.12	23.99	6.25	1.13	11.50	14.88	11.76	7.000	.75	26.91	ST
GW80	0279-00604	78 lbs.	8.000	6.38	11.12	25.50	7.00	1.13	12.50	17.00	12.25	8.000	.75	28.96	ST
GW100	0279-00605	156 lbs.	10.000	7.76	12.99	30.75	8.88	1.44	15.50	20.88	14.75	9.000	1.00	37.47	ST

* ST = STEEL, CI = CAST IRON

** CONSULT FACTORY FOR AVAILABILITY OF OPTIONAL CAST IRON MOUNTING FEET



NEMA "C" FLANGE ADAPTOR KITS

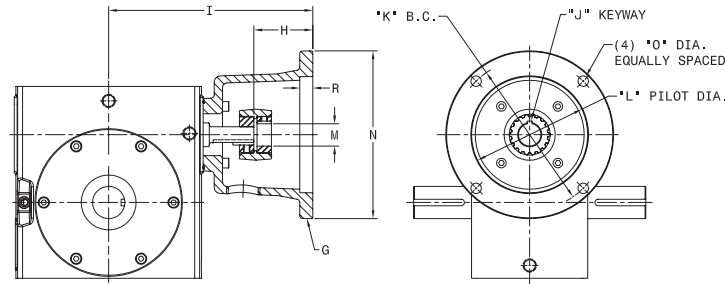

B

SERIES	G - NEMA FLANGE	FLANGE KIT NUMBER	FLANGE KIT SHIPPING WT.	H	I	J	K	L	M	N	O	R
130	56C	0229-02975	9.4 lbs.	2.21	6.03	3/16 X 3/32	5.875	4.501/4.503	.625	6.50	13/32	.38
180	56C	0229-02976	9.4 lbs.	2.21	6.40	3/16 X 3/32	5.875	4.501/4.503	.625	6.50	13/32	.38
210	56C	0229-02977	9.4 lbs.	2.28	6.91	3/16 X 3/32	5.875	4.501/4.503	.625	6.50	13/32	.50
	143TC, 145TC 182C, 184C	0229-02978	9.3 lbs.						.875			
W240	56C	0229-02977	9.4 lbs.	2.29	7.29	3/16 X 3/32	5.875	4.501/4.503	.625	6.50	13/32	.50
	143TC, 145TC 182C, 184C	0229-02978	9.3 lbs.						.875			
260	56C	0229-02979	10.0 lbs.	2.28	7.91	3/16 X 3/32	5.875	4.501/4.503	.625	6.50	13/32	.50
	143TC, 145TC 182C, 184C	0229-02980	9.9 lbs.						.875			
	182TC, 184TC 213C, 215C	0229-02981	22.5 lbs.						4.00			
320	56C	0229-02982	11.7 lbs.	2.18	9.06	3/16 X 3/32	5.875	4.501/4.503	.625	6.50	13/32	.20
	143TC, 145TC 182C, 184C	0229-02983	11.6 lbs.						.875			
	182TC, 184TC 213C, 215C	0229-02984	22.2 lbs.						3.44			
380	56C	0229-02985	11.5 lbs.	2.18	9.56	3/16 X 3/32	5.875	4.501/4.503	.625	6.50	13/32	.20
	143TC, 145TC 182C, 184C	0229-02986	11.4 lbs.						.875			
	182TC, 184TC 213C, 215C	0229-02987	22.0 lbs.						3.44			
450	56C	0229-02893	13.9 lbs.	2.44	10.88	3/16 X 3/32	5.875	4.501/4.503	.625	6.50	13/32	.20
	143TC, 145TC 182C, 184C	0229-02894							.875			
	182TC, 184TC 213C, 215C	0229-02895	22.8 lbs.						3.25			
520	56C	0229-02897	15.4 lbs.	2.38	11.63	3/16 X 3/32	5.875	4.501/4.503	.625	6.50	13/32	.20
	143TC, 145TC 182C, 184C	0229-02898							.875			
	182TC, 184TC 213C, 215C	0229-02899	24.9 lbs.						3.19			
GW60	182TC, 184TC 213C, 215C	0279-00622	28 lbs.	4.10	15.88	1/4 x 1/8	7.250	8.501/8.504	1.125	9.00	17/32	.19
	213TC, 215TC 254C, 256C	0279-00623				5/16 x 5/32			1.375			
	256TC, 256TC	0279-00624				3/8 x 3/16			1.625			
GW70	182TC, 184TC 213C, 215C	0279-00606	14 lbs.	4.19	15.69	1/4 x 1/8	7.250	8.501/8.504	1.125	9.25	17/32	.19
	213TC, 215TC 254C, 256C	0279-00607	5/16 x 5/32			1.375						
	256TC, 256TC	0279-00608	28 lbs.			3/8 x 3/16			1.625			
GW80	213TC, 215TC 254C, 256C	0279-00609	16 lbs.	4.27	16.77	5/16 x 5/32	7.250	8.501/8.504	1.375	9.25	17/32	.19
	256TC, 256TC	0279-00610	28 lbs.			3/8 x 3/16			1.625			

NOTE: THE C-FLANGE KITS REFERRED TO HERE ARE FOR SINGLE REDUCTION UNITS. REFER TO PAGE B-62 TO B-85 TO DETERMINE THE PRIMARY UNIT SERIES THAT IS USED TO MAKE UP A DOUBLE REDUCTION UNIT. SEE PAGE B-95 FOR C-FLANGE KITS TO BE USED FOR DOUBLE REDUCTION SIZES GW700 / GW1000.

CALL: (605) 225-0360 • FAX: (605) 225-0567

B-91

ACCESSORIES & OPTIONS



SIDE MOUNT FLANGE BRACKET KITS

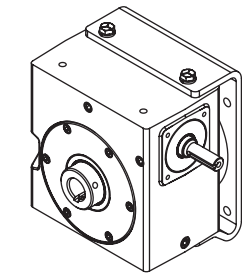
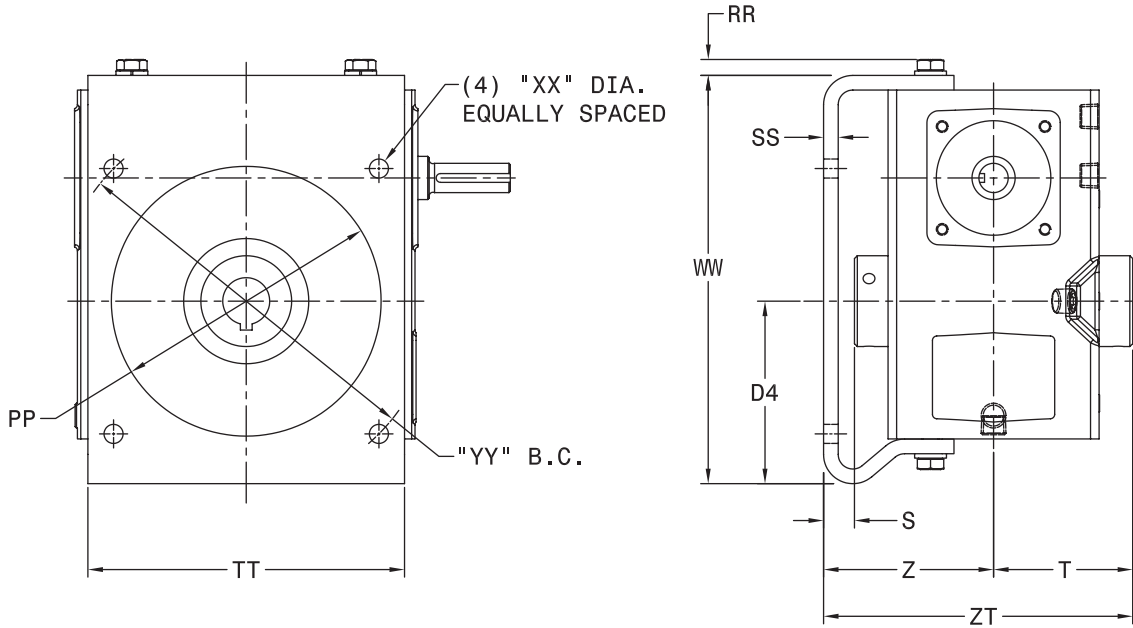

STYLE A SHOWN
W/KIT MOUNTED ON RIGHT

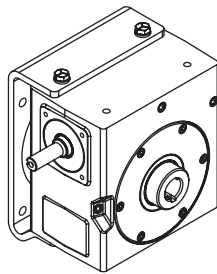

STYLE B SHOWN
W/KIT MOUNTED ON LEFT

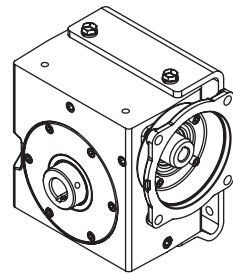

STYLE A SHOWN
W/KIT MOUNTED ON RIGHT

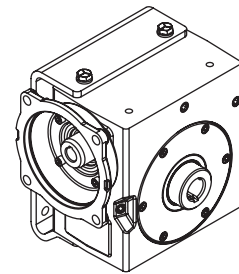

STYLE B SHOWN
W/KIT MOUNTED ON LEFT

NOTE: SIDE MOUNT KITS ARE INTENDED TO BE ATTACHED ON THE SIDE OPPOSITE OF THE PIPE PLUGS AND COVER OF A HOLLOW BORE UNIT, MODELS "XX2" OR "XX5" AS SHOWN. **CUSTOMER IS REQUIRED TO SPECIFY THE STYLE OF THE GEARBOX WHEN ORDERING TO ACCOMPLISH THIS.**

SERIES	SIDE MOUNT KIT NO.	SHIPPING WT. LBS.	D4	S	T	Z	PP	RR	SS	TT	WW	XX	YY	ZT
180	0229-02950	5.2	3.13	.91	2.41	3.31	4.25	.22	.25	4.88	6.50	11/32	5.875	5.71
210	0229-02951	7.5	3.75	.85	2.78	3.63	4.75	.33	.31	5.75	7.63	13/32	7.000	6.41
W240	0229-02952	7.1	3.61	.75	2.97	3.72	5.00	.33	.25	6.00	8.30	13/32	7.500	6.69
260	0229-02953	8.1	3.89	.66	2.97	3.63	5.75	.33	.31	6.75	8.70	13/32	8.000	6.60
	0229-02954	9.4	4.07	1.66	2.97	4.63	5.75	.33	.31	6.75	8.88	13/32	8.000	7.60
320	0229-02955	10.0	4.45	.22	3.78	4.00	6.88	.44	.31	7.50	10.14	13/32	9.000	7.78
380	0229-02956	12.1	5.09	.72	3.78	4.50	7.50	.44	.31	8.25	11.53	9/16	10.000	8.28



VERTICAL MOUNTING KITS

B

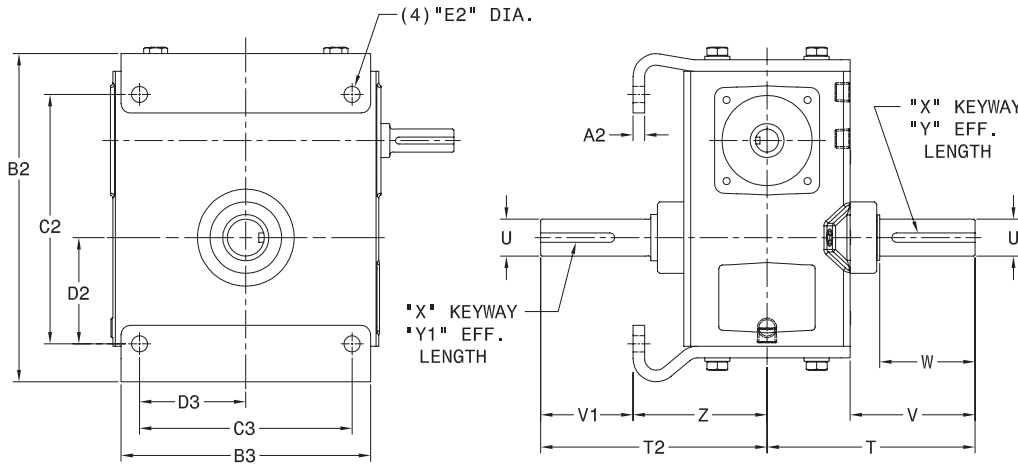

CONSULT FACTORY FOR VERTICAL SHAFT LUBRICATION RECOMMENDATIONS OR REVIEW VERTICAL SHAFT LUBRICATION INSTRUCTIONS INCLUDED IN KIT.

NOTE: VERTICAL MOUNT KITS ARE INTENDED TO BE ATTACHED SO THE MOUNTING FEET ARE ON THE SIDE OPPOSITE OF THE PIPE PLUGS AND COVER OF A HOLLOW BORE UNIT, MODELS "XX2" OR "XX5" AS SHOWN. CUSTOMER IS REQUIRED TO SPECIFY THE STYLE OF THE GEARBOX WHEN ORDERING TO ACCOMPLISH THIS.

BASE MODEL	STOCK BORE REQUIRED
182 OR 185	1.000
212 OR 215	1.000
242 OR 245	1.000

BASE MODEL	STOCK BORE REQUIRED
262 OR 265	1.000
322 OR 325	1.438
382 OR 385	1.938

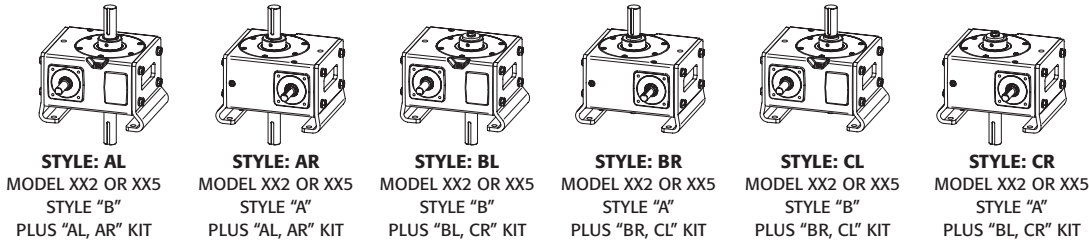

SERIES	STYLE	VERTICAL MT. KIT NO.	SHIP WT. LBS.	T	T2	U	V	V1	W	X	Y	Y1	Z	A2	B2	B3	C2	C3	D2	D3	E2
180	AL,AR	0229-02957	7.2	4.50	5.19	0.750 0.749	2.78	2.00	1.87	3/16	1.66	1.79	3.19	.25	7.00	4.75	5.00	4	2.13	2.00	.44*
	BL,CR	0229-02958	7.0	N/A	5.19		N/A	2.00	N/A	X	N/A	1.79									
	BR,CL	0229-02959	6.7	4.50	N/A		2.78	N/A	1.92	3/32	1.66	N/A									
210	AL,AR	0229-02960	9.9	5.00	5.50	0.875 0.874	2.94	2.25	1.99	3/16	1.79	1.73	3.25	.31	7.68	4.75	5.25	4	2.13	2.00	.44
	BL,CR	0229-02961	9.6	N/A	5.50		N/A	2.25	N/A	X	N/A	1.73									
	BR,CL	0229-02962	9.5	5.00	N/A		2.94	N/A	2.04	3/32	1.79	N/A									
W240	AL,AR	0229-02963	12.9	5.63	6.13	1.000 0.999	3.44	2.50	2.58	1/4	2.13	1.88	3.63	.31	9.98	6.50	7.75	5.75	2.38	2.88	.44*
	BL,CR	0229-02964	12.4	N/A	6.13		N/A	2.50	N/A	X	N/A	1.88									
	BR,CL	0229-02965	12.3	5.63	N/A		3.44	N/A	2.48	1/8	2.13	N/A									
260	AL,AR	0229-02966	12.5	5.63	6.13	1.000 0.999	3.38	2.50	2.58	1/4	2.13	1.88	3.63	.31	8.88	6.75	6.75	5.75	2.88	2.88	.44
	BL,CR	0229-02967	12.0	N/A	6.13		N/A	2.50	N/A	X	N/A	1.88									
	BR,CL	0229-02968	11.9	5.63	N/A		3.38	N/A	2.48	1/8	2.13	N/A									
320	AL,AR	0229-02969	17.3	6.38	7.00	1.250 1.249	3.78	2.75	2.31	1/4	2.06	2.06	4.25	.31	10.48	7.25	7.75	6.25	3.25	3.13	.56*
	BL,CR	0229-02970	16.5	N/A	7.00		N/A	2.75	N/A	X	N/A	2.06									
	BR,CL	0229-02971	16.3	6.38	N/A		3.78	N/A	2.35	1/8	2.16	N/A									
380	AL,AR	0229-02972	23.1	7.50	7.75	1.500 1.499	4.75	3.25	3.38	3/8	3.00	2.59	4.50	.31	11.69	8.00	9.00	7	3.75	3.50	.56
	BL,CR	0229-02973	21.5	N/A	7.75		N/A	3.25	N/A	X	N/A	2.59									
	BR,CL	0229-02974	21.3	7.50	N/A		4.75	N/A	3.47	3/16	3.00	N/A									

* SLOTTED HOLES

ACCESSORIES & OPTIONS



UNIVERSAL MOUNTING SPACER

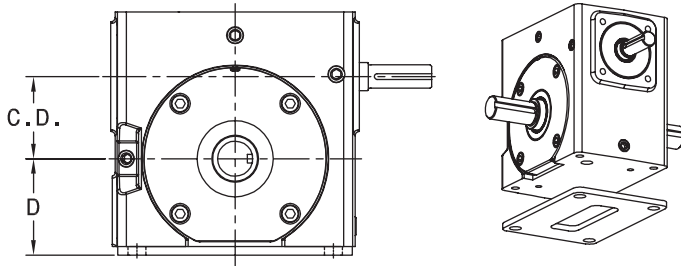

UNIVERSAL MOUNTING SPACERS ARE DESIGNED TO MATCH THE "D" MOUNTING HEIGHT FROM THE OUTPUT CENTERLINE TO THE BOTTOM MOUNTING SURFACE OF COMPETITIVE UNITS.

SERIES	SPACER PART NO.	SPACER SHIPPING WT.	C.D.	D (WITH SPACER)	D (WITHOUT SPACER)
130	0223-07625	1.0 LBS.	1.334	1-23/32	1-9/16
180	0223-07626	1.3 LBS.	1.751	2-1/16	1-7/8
210	NOT AVAILABLE - CONSULT FACTORY		2.064	N/A	2-7/16
W240	NOT REQUIRED	-	2.376	-	2-1/2
260	NOT REQUIRED	-	2.626	-	2-15/16
320	0223-07627	3.5 LBS.	3.251	3-1/2	3-1/4
380	NOT AVAILABLE - CONSULT FACTORY		3.751	N/A	3-15/16

FANS

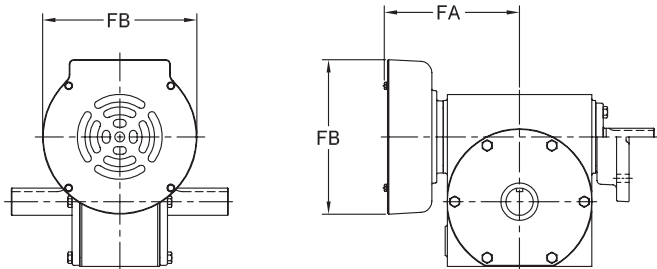

WHEN FAN KITS AND THERMAL BLOCK KITS ARE UTILIZED, SYNTHETIC LUBRICANT IS RECOMMENDED. SEE SECTION R.

SERIES	INPUT	FAN KIT PART NO.	FAN KIT SHIPPING WT.	FA	FB
450	SHAFT	0229-02891	11 LBS.	7-3/4	9-5/8
	QUILL	0229-02982			
520	SHAFT	0229-02896	11 LBS.	8-1/2	9-5/8
	QUILL	0229-02892			

THERMAL BLOCK KITS

SERIES	THERMAL BLOCK KIT PART NO.	THERMAL BLOCK KIT SHIPPING WT.	FC
450	0229-00033	4 LBS.	4-3/16
520	0229-00034	5 LBS.	4-5/16

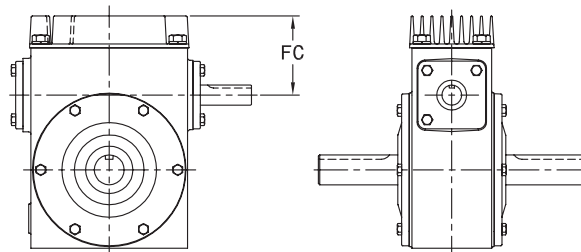



TORQUE ARM KITS

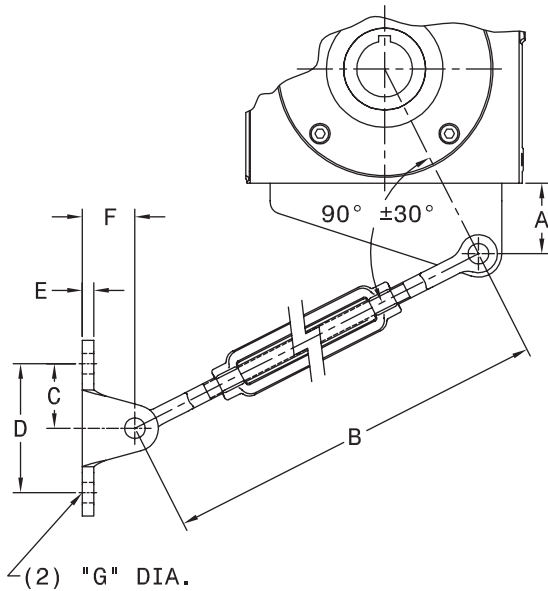

MODEL*	TORQUE ARM KIT NUMBER	A	B	C	D	E	F	G
182, 185	0229-02996	1.37	11.13 MIN. 17 MAX.	1-3/8	2-3/4	1/4	1.13	7/16
212, 215	0229-02997	1.50	11.13 MIN. 17 MAX.	1-3/8	2-3/4	1/4	1.13	7/16
242, 245	0229-02998	1.75	11.13 MIN. 17 MAX.	1-3/8	2-3/4	1/4	1.13	7/16
262, 265	0229-02999	2.00	11.13 MIN. 17 MAX.	1-3/8	2-3/4	1/4	1.13	7/16
322, 325	0229-03000	2.25	11.13 MIN. 17 MAX.	1-3/8	2-3/4	1/4	1.13	7/16
382, 385	0229-03001	2.50	11.13 MIN. 17 MAX.	1-3/8	2-3/4	1/4	1.13	7/16
452, 455	0229-02604	1.25	12.50 MIN. 18.38 MAX.	1-5/8	3-1/4	1/2	1.25	21/32
522, 525	0229-02679	1.50	12.50 MIN. 18.38 MAX.	1-5/8	3-1/4	1/2	1.25	21/32
GW602, GW605	0279-00625	5.000	27.00 MIN. 31.00 MAX.	1-13/16	3-5/8	1/4	1.32	21/32

* SAME KITS ARE USED WHEN THE MODEL IS THE FINAL UNIT ON A DOUBLE REDUCTION OR TRIPLE REDUCTION WORM GEAR REDUCER.

C FLANGE MOTOR MOUNTING KITS

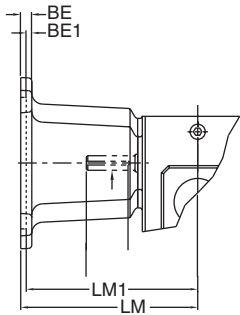

DOUBLE REDUCTION (FITS PRIMARY UNIT)

UNIT SIZE	FLANGE SIZE	KIT NUMBER	BE	BE1	LM	LM1	SHIPPING WT (LBS)
GW60D & GW70D	56C	0279-00611	0.38	N/A	9.01	N/A	7
	140TC	0279-00612	0.38	N/A	9.01	N/A	7
	180TC	0279-00613	N/A	0.5	N/A	10.01	11
	210TC	0279-00614	N/A	0.5	N/A	10.01	11
GW80D & GW100D	56C	0279-00615	0.38	N/A	11.81/13.21 [^]	N/A	8
	140TC	0279-00616	0.38	N/A	11.81/13.21 [^]	N/A	8
	180TC	0279-00617	N/A	0.5	N/A	12.90/14.30 [^]	11
	210TC	0279-00618	N/A	0.5	N/A	12.90/14.30 [^]	11
	250TC	0279-00619	N/A	0.5	N/A	13.46/14.86 [^]	12

[^]FIRST VALUE LISTED APPLIES TO GW80D/SECOND VALUE APPLIES TO GW100D

SERVO MOTOR FLANGES and HYDRAULIC INPUT FLANGES

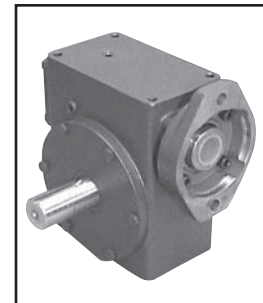
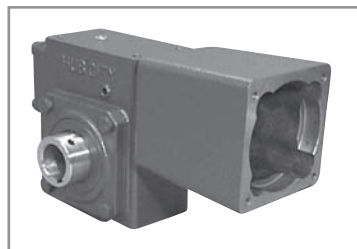

Servo Motor Flanges and Hydraulic Input Flanges are available as factory options. Consult Factory for complete specifications.



EXTENDED WORM SHAFTS

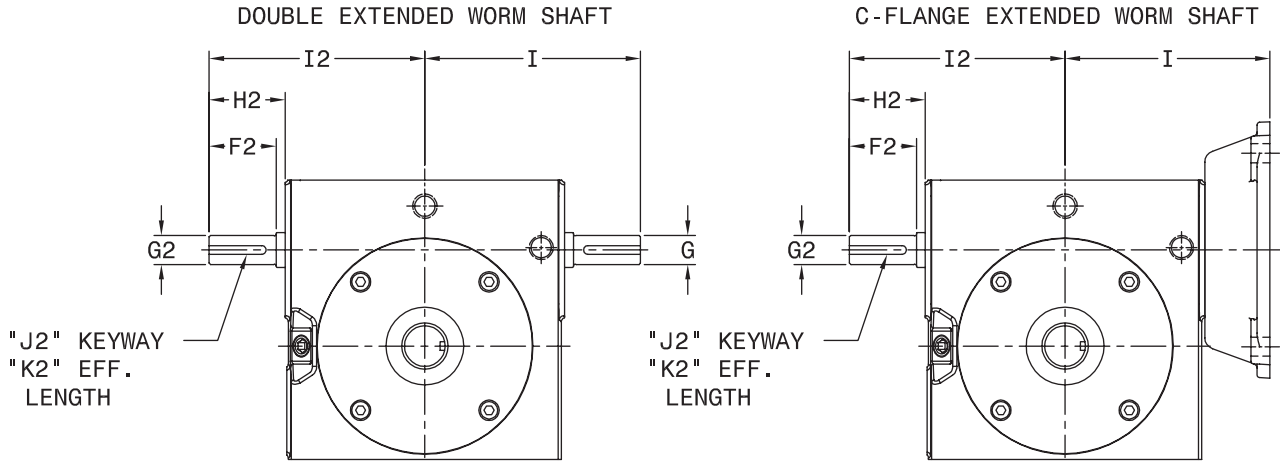

NEW! DOUBLE EXTENDED WORM SHAFT DIMENSIONS

SERIES	F2	G	G2	H2	I	I2	J2	K2
130 SHAFT INPUT	1.35	.500/.499	.500/.499	1.54	3.82	3.82	1/8 X 1/16	1.16
180 SHAFT INPUT	1.35	.500/.499	.500/.499	1.54	4.19	4.19	1/8 X 1/16	1.16
210 SHAFT INPUT	1.44	.625/.624	.625/.624	1.63	4.63	4.63	3/16 X 3/32	1.13
W240 SHAFT INPUT	1.43	.625/.624	.625/.624	1.63	5.00	5.00	3/16 X 3/32	1.21
260 SHAFT INPUT	1.73	.625/.624	.625/.624	1.97	5.63	5.63	3/16 X 3/32	1.49
320 SHAFT INPUT	2.23	.875/.874	.875/.874	2.48	6.88	6.88	3/16 X 3/32	1.91
380 SHAFT INPUT	2.20	1.000/.999	1.000/.999	2.48	7.38	7.38	1/4 X 1/8	1.91
450 SHAFT INPUT	2.98	1.125/1.124	1.000/.999	3.21	8.44	8.44	1/4 X 1/8	2.50
520 SHAFT INPUT	3.02	1.250/1.249	1.000/.999	3.27	9.25	9.25	1/4 X 1/8	2.47

NEW! C-FLANGE EXTENDED WORM SHAFT DIMENSIONS

SERIES	F2	G2	H2	I	I2	J2	K2
130 QUILL INPUT	1.35	.500/.499	1.54	3.63	3.82	1/8 X 1/16	1.16
180 QUILL INPUT	1.35	.500/.499	1.54	4.00	4.19	1/8 X 1/16	1.16
210 QUILL INPUT	1.44	.625/.624	1.63	4.50	4.63	3/16 X 3/32	1.13
W240 QUILL INPUT	1.43	.625/.624	1.63	SEE SERIES W240 PAGES	5.00	3/16 X 3/32	1.21
260 QUILL INPUT	1.73	.625/.624	1.97	SEE SERIES 260 PAGES	5.63	3/16 X 3/32	1.49
320 QUILL INPUT	2.23	.875/.874	2.48	SEE SERIES 320 PAGES	6.88	3/16 X 3/32	1.91
380 QUILL INPUT	2.20	1.000/.999	2.48	SEE SERIES 380 PAGES	7.38	1/4 X 1/8	1.91
450 QUILL INPUT	2.50	1.000/.999	2.79	6.75	8.44	1/4 X 1/8	2.00
520 QUILL INPUT	2.59	1.000/.999	2.83	7.50	9.25	1/4 X 1/8	2.03

REF. - OLD DOUBLE EXTENDEND WORM SHAFT DIMS.				REF. - OLD C-FLANGE EXTENDEND WORM SHAFT DIMS.		
SERIES	G2	H2	I2	G2	H2	I2
130	.437/.436	1.50	3.50	.437/.436	2.22	4.22
180	.500/.499	1.53	4.00	.437/.436	2.25	4.72
210	.625/.624	1.54	4.44	.562/.560	1.66	4.56
260	.625/.624	2.22	5.62	.562/.560	2.22	5.62
320	.875/.874	2.56	6.75	.750/.749	2.70	6.90
380	1.000/.999	2.43	7.13	.750/.749	2.58	7.28
450	NO CHANGE					
520	NO CHANGE					



GW WORM GEAR SERIES
OPTIONAL SIDE MOUNTING FLANGE DETAIL

B

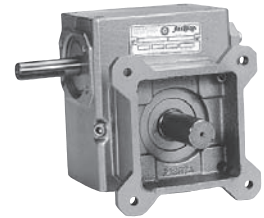
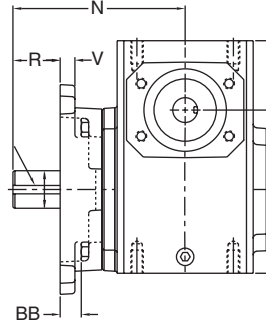
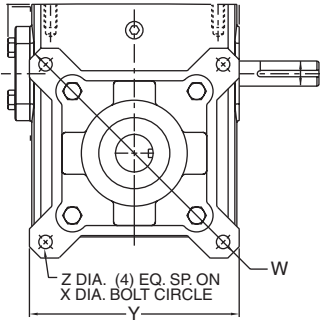

UNIT	BB	N	NN	R	T	V	W	X DIA.	Y	Z DIA.	WT. LBS.
GW60	1.38	10.00	5.75	2.74	13.01	.75	18.00	15.63	14.00	.69	38
GW70	1.57	11.76	6.75	4.32	14.20	.75	21.00	18.38	15.63	.78	45
GW80	1.89	12.25	7.25	3.92	15.59	.75	24.00	21.00	17.88	1.03	50
GW100	1.85	14.75	9.25	5.70	18.32	1.00	29.00	25.00	21.19	1.03	55

NOTE:
 MOUNTING FLANGE AVAILABLE WITH SOLID OUTPUT OR HOLLOW BORE
 UNITS, SINGLE OR DOUBLE REDUCTION. MUST BE ORDERED WITH GEAR
 DRIVE. NOT AVAILABLE IN KIT FORM.

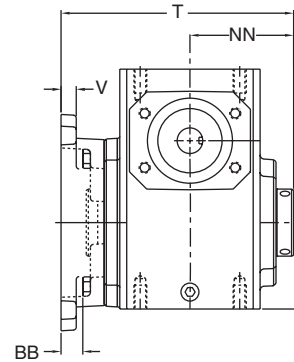
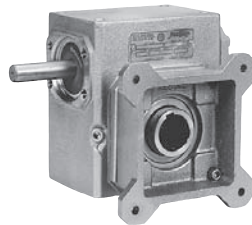

ACCESSORIES & OPTIONS



DIMENSIONAL COMPARISON HUB CITY OLD TO NEW STYLE (GW SERIES)

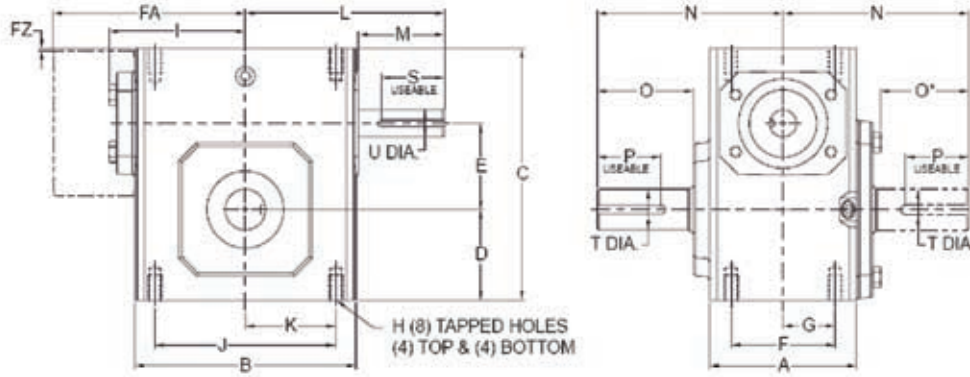

SERIES	A	B	C	D	E	F	FA	FZ	G	H	H DEPTH
GW60	8.13	14.50	16.50	6.500	6	6.380	11.13	0.000	3.190	5/8 UNC	1.00
60	6.75	13.25	15.88	6.625	6	4.875	10.06	-2.625	2.438	7/8 UNC	1.88
GW70	7.63	14.88	18.91	7.590	7	5.500	11.37	0.350	2.750	1 UNC	1.56
70	7.75	15.19	18.50	7.625	7	5.500	11.50	-2.500	2.750	1 UNC	2.00
GW80	8.63	17.00	20.96	8.860	8	6.500	12.52	0.570	3.250	1 UNC	1.66
80	9.00	17.75	21.25	8.750	8	6.500	13.09	-2.500	3.250	1 UNC	2.00

UNIT	I	J	K	L	M	N	O	P**	S**	T DIA.	U DIA.
GW60	N/A	12.75	6.38	11.78	3.41	10.00	4.65	5/8 X 4.00	3/8 X 3.00	2.50	1.500
60	N/A	11.00	5.50	10.75	3.46	10.25	5.12	1/2 X 4.25	3/8 X 2.81	2.25	1.500
GW70	N/A	12.50	6.25	11.50	2.97	11.76	5.65	5/8 X 4.00	3/8 X 2.87	2.75	1.625
70	N/A	12.50	6.25	12.00	3.63	11.13	5.44	5/8 X 5.00	3/8 X 3.13	2.75	1.750
GW80	N/A	14.25	7.13	12.50	2.84	12.25	5.98	3/4 X 4.50	1/2 X 2.81	3.00	1.875
80	N/A	14.75	7.38	13.63	3.88	12.75	6.25	3/4 X 5.63	1/2 X 3.38	3.25	1.875

EXTENDED BEARING UNITS

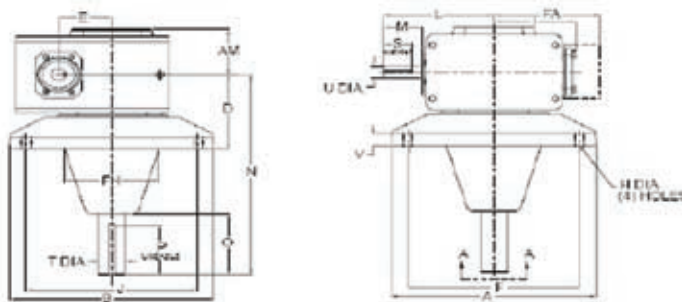

SERIES	A	B	D	F	FH	H DIA.	J	N	O	P**	T DIA.	V
GW60	19.50	19.50	7.00	17	9.50	0.938	17	22.50	7.630	5/8 X 6.50	2.438	1.50
60	19.50	19.50	8.25	17	8.50	0.938	17	23.75	7.625	5/8 X 6.50	2.438	1.25
GW70	22.00	22.00	8.50	19	10.75	1.13	19	24.00	7.630	3/4 X 6.44	2.937	1.75
70	22.25	22.25	10.25	19	9.03	1.06	19	25.75	7.625	3/4 X 6.69	2.937	1.50
GW80	28.00	28.00	10.00	24	13.75	1.31	24	27.06	9.250	7/8 X 8.00	3.438	2.00
80	24.25	24.25	11.25	21	10.44	1.31	21	27.31	8.313	7/8 X 7.63	3.438	1.75

**KEYWAY WIDTH BY LENGTH